



# Quick Start Guide

## UTL1000S Series Programmable DC Electronic Load

## Limited Warranty and Liability

Uni-T guarantees that the Instrument product is free from any defect in material and workmanship within three years from the purchase date. This warranty does not apply to damages caused by accident, negligence, misuse, modification, contamination, or improper handling. If you need a warranty service within the warranty period, please contact your seller directly. Uni-T will not be responsible for any special, indirect, incidental, or subsequent damage or loss caused by using this device. For the probes and accessories, the warranty period is one year. Visit [instrument.uni-trend.com](http://instrument.uni-trend.com) for full warranty information.

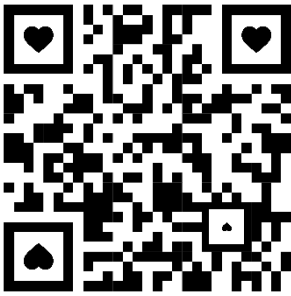

Scan to Download relevant document, software, firmware and more.



Register your product to confirm your ownership. You will also get product notifications, update alerts, exclusive offers and all the latest information you need to know.

**UNI-T** is the licensed trademark of UNI-TREND TECHNOLOGY (CHINA) CO., Ltd.

UNI-T products are protected under patent laws in China and internationally, covering both granted and pending patents. Licensed software products are the properties of UNI-Trend and its subsidiaries or suppliers, all rights reserved. This manual contains information that replaces all earlier published versions. The product information in this document subject to update without notice. For more information on UNI-T Test & Measure Instrument products, applications, or service, please contact UNI-T instrument for support, the support center is available on [www.uni-trend.com](http://www.uni-trend.com) -> [instruments.uni-trend.com](http://instruments.uni-trend.com)  
<https://instruments.uni-trend.com/ContactForm/>

### Headquarter

UNI-TREND TECHNOLOGY (CHINA)  
CO., Ltd.  
Address: No.6, Industrial North 1st  
Road, Songshan Lake Park, Dongguan  
City, Guangdong Province, China  
Tel: (86-769)8572 3888

### Europe

UNI-TREND TECHNOLOGY EU GmbH  
Address: Steinerne Furt 62, 86167  
Augsburg, Germany  
Tel: +49 (0)821 8879980

### North America

UNI-TREND TECHNOLOGY US INC.  
Address: 2692 Gravel Drive,  
Building 5, Fort Worth, Texas 76118  
Tel: +1-888-668-8648



## Foreword













Thank you for choosing this UNI-T instrument. For safe and proper use this instrument, please read this manual carefully, especially the safety instructions section.

After reading this manual, it is recommended to keep the manual in a convenient location, preferably near the device, for future reference.

## Safety Instructions

This chapter contains information and warnings that must be observed. Ensure that the instrument is operated under the safe conditions. In addition to the safety precautions indicated in this chapter, you must also follow accepted safety procedures.

Safety Precautions		
<b>Warning</b>	Please follow these guidelines to avoid possible electric shock and risk to personal safety.	
	<p>Users must adhere to standard safety precautions during the operation, servicing, and maintenance of this device. UNI-T will not be liable for any personal safety and property loss caused by the user's failure following the safety precautions. This device is designed for professional users and responsible organizations for measurement purposes.</p> <p>Do not use this device in any manner not specified by the manufacturer. This device is intended for indoor use only, unless otherwise stated in the product manual.</p>	
Safety Statements		
<b>Warning</b>	"Warning" indicates the presence of a hazard. It warns users to pay attention to a certain operation process, operation method or similar. Personal injury or death may occur if the rules in the "Warning" statement are not properly executed or observed. Do not proceed to the next step until you fully understand and meet the conditions stated in the "Warning" statement.	
<b>Caution</b>	"Caution" indicates the presence of a hazard. It warns users to pay attention to a certain operation process, operation method or similar. Product damage or loss of important data may occur if the rules in the "Caution" statement are not properly executed or observed. Do not proceed to the next step until you fully understand and meet the conditions stated in the "Caution" statement.	
<b>Note</b>	"Note" indicates important information. It reminds users to pay attention to procedures, methods, and conditions, etc. The contents of "Note" should be highlighted if necessary.	
Safety Signs		
	<b>Danger</b>	It indicates danger of electric shock, which may cause personal injury or death.
	<b>Warning</b>	It indicates that there are factors you should be cautious of to prevent personal injury or product damage.
	<b>Caution</b>	It indicates danger, which may cause damage to this device or other equipment if you fail to follow a certain procedure or condition. If the "Caution" sign is present, all conditions must be met before you proceed to operation.

	<b>Note</b>	It indicates potential problems, which may cause failure of this device if you fail to follow a certain procedure or condition. If the "Note" sign is present, all conditions must be met before this device will function properly.
	<b>AC</b>	Alternating current of device. Please check the region's voltage range.
	<b>DC</b>	Direct current device. Please check the region's voltage range.
	<b>Grounding</b>	Frame and chassis grounding terminal
	<b>Grounding</b>	Protective grounding terminal
	<b>Grounding</b>	Measurement grounding terminal
	<b>OFF</b>	Main power off
	<b>ON</b>	Main power on
	<b>Power</b>	Standby power supply: When the power switch is turned off, this device is not completely disconnected from the AC power supply.
<b>CAT I</b>		Secondary electrical circuit connected to wall sockets through transformers or similar equipment, such as electronic instruments and electronic equipment; electronic equipment with protective measures, and any high-voltage and low-voltage circuits, such as the copier in the office.
<b>CAT II</b>		Primary electrical circuit of the electrical equipment connected to the indoor socket via the power cord, such as mobile tools, home appliances, etc. Household appliances, portable tools (e.g., electric drill), household sockets, sockets more than 10 meters away from CAT III circuit or sockets more than 20 meters away from CAT IV circuit.
<b>CAT III</b>		Primary circuit of large equipment directly connected to the distribution board and circuit between the distribution board and the socket (three-phase distributor circuit includes a single commercial lighting circuit). Fixed equipment, such as multi-phase motor and multi-phase fuse box; lighting equipment and lines inside large buildings; machine tools and power distribution boards at industrial sites (workshops).
<b>CAT IV</b>		Three-phase public power unit and outdoor power supply line equipment. Equipment designed to "initial connection," such as power distribution system of power station, power instrument, front-end overload protection, and any outdoor transmission line.
	<b>Certification</b>	CE indicates a registered trademark of EU.
	<b>Certification</b>	UKCA indicates a registered trademark of United Kingdom.
	<b>Certification</b>	Conforms to UL STD 61010-1 and 61010-2-030. Certified to CSA STD C22.2 No.61010-1 and 61010-2-030.
	<b>Waste</b>	Do not place equipment and accessories in the trash. Items must be properly disposed of in accordance with local regulations.

	<p>EEUP</p>	<p>This environment-friendly use period (EFUP) mark indicates that dangerous or toxic substances will not leak or cause damage within this indicated time period. The environmentally friendly use period of this product is 40 years, during which it can be used safely. Upon expiration of this period, it should enter the recycling system.</p>
<p><b>Safety Requirements</b></p>		
<p style="text-align: center;"><b>Warning</b></p>		
<p><b>Preparation before use</b></p>	<p>Please connect this device to AC power supply with the power cable provided. The AC input voltage of the line reaches the rated value of this device. See the product manual for specific rated value. The line voltage switch of this device matches the line voltage. The line voltage of the line fuse of this device is correct. This device is not intended for measuring the main circuit.</p>	
<p><b>Check all terminal rated values</b></p>	<p>Please check all rated values and marking instructions on the product to avoid fire and the impact of excessive current. Please consult the product manual for detailed rated values before connection.</p>	
<p><b>Use the power cord properly</b></p>	<p>You can only use the special power cord for the instrument approved by the local and state standards. Please check whether the insulation layer of the cord is damaged, or the cord is exposed, and test whether the cord is conductive. If the cord is damaged, please replace it before using the instrument.</p>	
<p><b>Instrument Grounding</b></p>	<p>To avoid electric shock, the grounding conductor must be connected to the ground. This product is grounded through the grounding conductor of the power supply. Please be sure to ground this product before it is powered on.</p>	
<p><b>AC power supply</b></p>	<p>Please use the AC power supply specified for this device. Please use the power cord approved by your country and confirm that the insulation layer is not damaged.</p>	
<p><b>Electrostatic prevention</b></p>	<p>This device may be damaged by static electricity, so it should be tested in the anti-static area if possible. Before the power cable is connected to this device, the internal and external conductors should be grounded briefly to release static electricity. The protection grade of this device is 4 kV for contact discharge and 8 kV for air discharge.</p>	
<p><b>Measurement accessories</b></p>	<p>Measurement accessories designated as lower-grade, which are not applicable to main power supply measurement, CAT II, CAT III, or CAT IV circuit measurement. Probe subassemblies and accessories within the range of IEC 61010-031 and current sensors within the range of IEC 61010-2-032 can meet its requirements.</p>	
<p><b>Use the input / output port of this device properly</b></p>	<p>Please use the input / output ports provided by this device in a proper manner. Do not load any input signal at the output port of this device. Do not load any signal that does not reach the rated value at the input port of this device. The probe or other connection accessories should be effectively grounded to avoid product damage or abnormal function. Please refer to the product manual for the rated value of the input / output port of this device.</p>	
<p><b>Power fuse</b></p>	<p>Please use a power fuse of exact specification. If the fuse needs to be replaced, it must be replaced with another one that meets the specified specifications by the maintenance personnel authorized by UNI-T.</p>	

<b>Disassembly and cleaning</b>	There are no components available for operators inside. Do not remove the protective cover. Qualified personnel must conduct maintenance.
<b>Service environment</b>	This device should be used indoors in a clean and dry environment with ambient temperature from 0 °C to +40 °C. Do not use this device in explosive, dusty, or high humidity conditions.
<b>Do not operate in humid environment</b>	Do not use this device in a humid environment to avoid the risk of internal short circuit or electric shock.
<b>Do not operate in flammable and explosive environment</b>	Do not use this device in a flammable and explosive environment to avoid product damage or personal injury.
<b>Caution</b>	
<b>Abnormality</b>	If this device may be faulty, please contact the authorized maintenance personnel of UNI-T for testing. Any maintenance, adjustment or parts replacement must be done by the relevant personnel of UNI-T.
<b>Cooling</b>	Do not block the ventilation holes at the side and back of this device. Do not allow any external objects to enter this device via ventilation holes. Please ensure adequate ventilation and leave a gap of at least 15 cm on both sides, front and back of this device.
<b>Safe transportation</b>	Please transport this device safely to prevent it from sliding, which may damage the buttons, knobs, or interfaces on the instrument panel.
<b>Proper ventilation</b>	Insufficient ventilation will cause the device temperature to rise, thus causing damage to this device. Please keep proper ventilation during use, and regularly check the vents and fans.
<b>Keep clean and dry</b>	Please take actions to avoid dust or moisture in the air affecting the performance of this device. Please keep the product surface clean and dry.
<b>Note</b>	
<b>Calibration</b>	The recommended calibration period is one year. Calibration should only be conducted by qualified personnel.

# Chapter 1 Panel

## 1.1 Front Panel

The product has a simple, intuitive and easy to use front panel, as shown in the following figure.

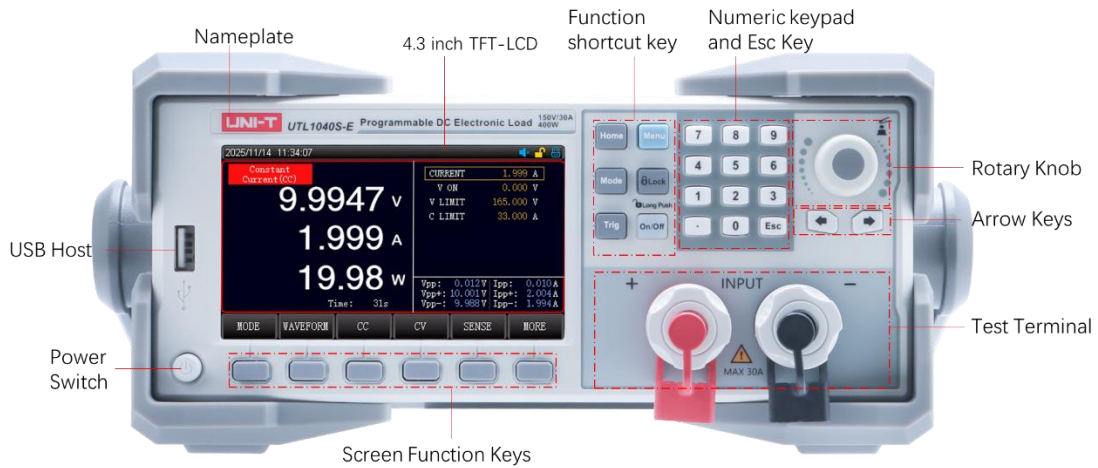

For more details, please refer to UTL1000S Series Programmable DC Electronic Load User Manual.

## 1.2 Rear Panel

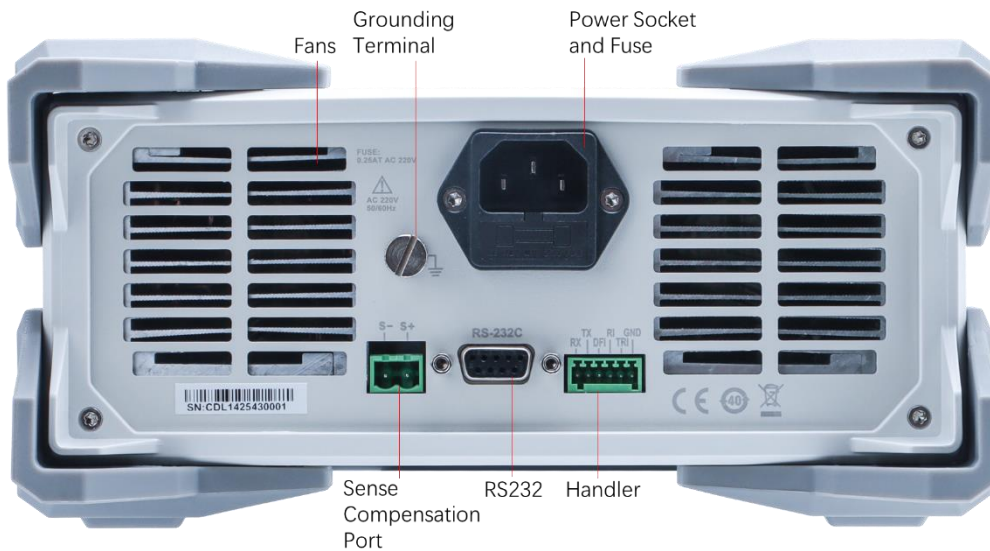

For more details, please refer to UTL1000S Series Programmable DC Electronic Load User Manual.

### 1.3 Handle

Handle can adjust to three positions by appropriate strengths.

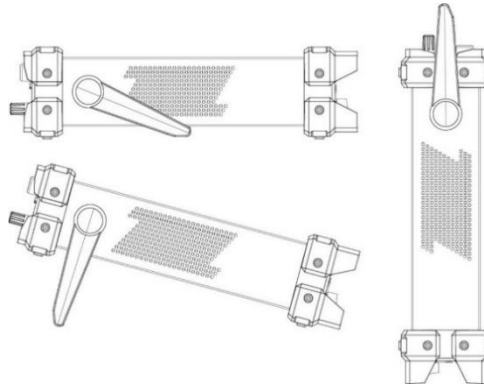

Hold the handle and pull to two sides to remove it. Adjusting the handle to the position as shown in the following figure. Please be careful of your hands when remove the handle.

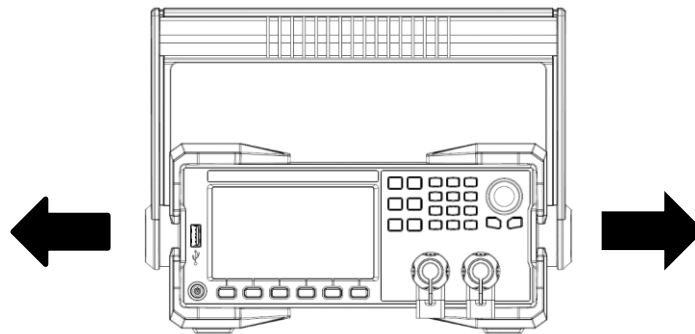

## Chapter 2 User's Guide

This manual includes safety requirements and the operation of UTL1000S Series Programmable DC Electronic Load.

UTL1000S series DC electronic load are a new generation of intelligent, large-screen and cost-effective electronic loads. The synchronizing sampling is up to 500 kHz, with high-performance DSP processing, built-in self-adaptive voltage and current waveform display, convenient for transient testing and multi-faceted intelligent simulation and analysis. Fast, efficient, visualized LIST programmable automated test modes for most R&D and test needs.

Model	Input Range
UTL1020S	0-150V, 0-30A, 0-200W
UTL1020S-E	0-150V, 0-30A, 0-200W
UTL1040S	0-150V, 0-30A, 0-400W
UTL1040S-E	0-150V, 0-30A, 0-400W

## 2.1 Inspecting Packaging and List

When you receive the instrument, please make sure to check the packaging and list by the following steps:

- Check whether the packing box and padding material are extruded or teased caused by external forces, and the appearance of the instrument. If you have any questions about the product or need consulting services, please contact the distributor or local office.
- Carefully take out the article and check it with the packing list.

## 2.2 Operating Environment

This instrument is suitable for the following environment:

Operating Environment	Requirements
Operating temperature	0 °C ~40 °C
Operating humidity	20%~80% (non-condensation)
Storage temperature	-20 °C ~60 °C
Altitude	≤2000 meters
Pollution degree	2

There are ventilation opening on the rear panel and side panel of the instrument. So please keep the air flowing through the vents of the instrument housing. To prevent excessive dust from blocking the vents, please clean the instrument housing regularly. The housing is not waterproof, please disconnect the power supply first and then wipe the housing with a dry cloth or a slightly moistened soft cloth.

## 2.3 Connect Power Supply

The specification of input AC power for UTL1000S Series:

AC Input	Frequency	Specification of Fuse
220V±10%	50/60Hz	250V/T0.25A
110V±10%	50/60Hz	250V/T0.5A

Please use the attached power lead to connect to the power port.

Connecting to service cable

The supplied power lead has good performance in terms of case ground. This electronic load is equipped with a three-prong power cable that meets international safety standards. It provides good case grounding performance for the specification of your country or region.

Please install AC power cable as follow,

- Ensure the power cable is in a good condition.
- Leave enough space for connecting the power cord.
- Plug the attached three-prong power cable into a well-grounded power socket.

## 2.4 Electrostatic Protection

Electrostatic discharge may cause damage to component. Components can be damaged invisibly by electrostatic discharge during transportation, storage and use.

The following measure can reduce the damage of electrostatic discharge.

- Testing in anti-static area as far as possible
- Before connecting the power cable to the instrument, inner and outer conductors of the instrument should be briefly grounded to discharge static electricity;
- Ensure all the instruments are properly grounded to prevent the accumulation of static.

## 2.5 Preparation

1. Connect the power supply wire;

2. Press the switch  on the front panel, the instrument is booting-up.

## 2.6 Remote Control

UTL1000S Series Programmable DC Electronic Load supports communication with the computer via RS232 interface. Users can use programming language SCPI via RS232 interface to remote control the instrument.

The detailed information about programming, please refer to UTL1000S Series Programming Manual.

# Chapter 3 Quick Start

## 3.1 Wire Connecting

1. Connect the positive output end of the power supply to the positive end of the electronic load power supply, and the negative output end of the power supply to the negative end of the electronic load.

Note: The UTL1000S Series load front panel contains the following terminals and the maximum rated current of the terminal at position (A) is 120A and the maximum rated current at (B) is 10A.

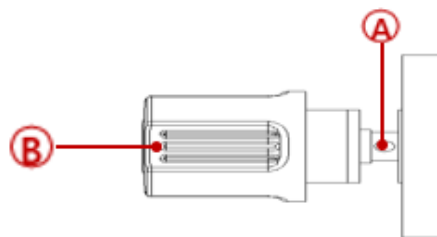

2. If the Sense function is used, users need to press the [Sense] key at the bottom of the screen, and connect the positive output end of the power supply to the positive end of the electronic load SENSE, and the negative output end of the power supply to the negative end of the electronic load SENSE.

3. Power on the output function of power supply, electronic load press [On/Off] key, start the test.

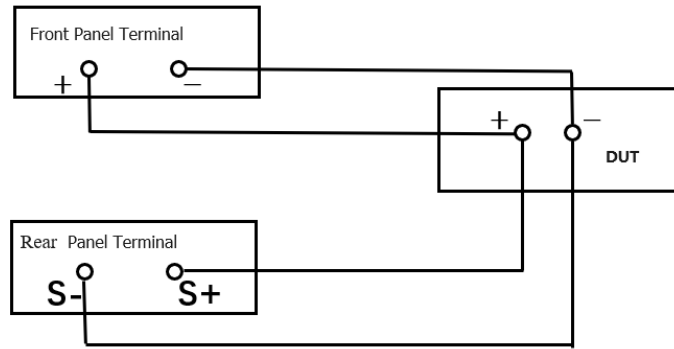

### 3.2 Mode Setting

Press [Mode] and use the rotary knob to select the mode.



### 3.3 Mode Description

CC/CV/CR/CP Mode show as below:

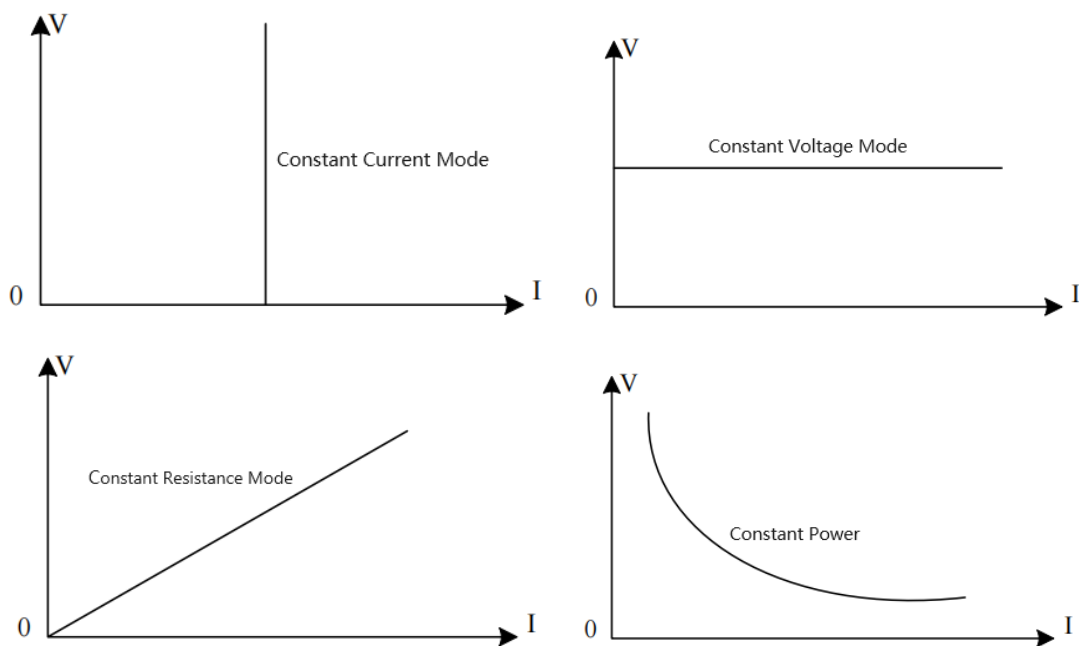

Other Mode	Description
Dynamic test	Set two different current/voltage values. This allows the electronic load to step through the two levels under test.
OVP test	Set the value of overcurrent, overpower and overvoltage, to detect the protection function of the DUT is worked. During the test, the electronic load constantly increases the set load value to detect the protective value of the DUT.
Time test	Specifically for the start/fall time test of power switch. Set the start and end values for the load mode, when the voltage of the DUT is stable and then to detect the time from rise to stable.
OCP test	Set the value of overcurrent, overpower and overvoltage, to detect the protection function of the DUT is worked. During the test, the electronic load constantly increases the set load value to detect the protective value of the DUT.
CR-LED test	During the test, the electronic load constantly increases the set load value to detect the protective value of the DUT. CR-LED test for LED power supply, it simulates the operating parameter, set the voltage/current of operating point and LED coefficient, so that the performance of LED power can be detected.
Battery test	Three discharge modes: CC/CR/CP Use CC/CR/CP to discharge the DUT's power. The test stops automatically and displays the battery capacity and discharge curve when it reaches the cut-off point.
Auto list test	The automatic list test function can switch between different modes according to the set parameters. For power products and chargers, etc., through multi-parameter hybrid testing, the comprehensive working characteristics of the tested products can be more comprehensively and deeply understood in practical applications.
Short test	The electronic load can simulates a short-circuited circuit at the input terminal, it is used to detect whether the protection function of DUT is working when the output terminal of the DUT is short-circuited.
Load effect	Three different loads are loaded according to the set load value and calculate V and Reg (load regulation ratio).
Dual test	The combination test consists of two types of constant mode: CR+CC, CV+CR, CV+CC. It can meet the demands for more constant mode.
List test	List testing is used for simulation of real loads, or complex carrier-like editing, where loads are consecutively loaded according to the sequence edited in the file.

For more details, please refer to UTL1000S Series Programmable DC Electronic Load User Manual.

## Chapter 4 Troubleshooting

Possible faults in use of UTL1000S Series Programmable DC Electronic Load and troubleshooting methods are listed below. Please handle fault as the corresponding steps. If it cannot be handled, please contact with the distributor or local office and provide the model information (press **Menu** → **Device Info** to check).

The Electronic Load fails to start properly, see the following procedure to check and deal with it.

1. Check whether the power cable is connected correctly and make sure the electronic load is powered on.
2. Check whether the electronic load is turned on and the power switch is switched on.
3. Check whether the fuse is burned out.

If the fuse is burned out, replace the fuse as the following steps.

- 1) Turn off the electronic load and plug out the power cable, use tweezers or screwdriver to take out the fuse box (fuse position refer to Rear Panel figure).
- 2) Check whether the fuse is damaged, if it is really damaged, replace the fuse according to the model.

The specification of fuse as shown in the following table.

AC Input	Frequency	Specification of Fuse
220V±10%	50/60Hz	250V/T0.25A
110V±10%	50/60Hz	250V/T0.5A

- 3) Replace the fuse of the same specification, put it in the box, and re-power it.

## Chapter 5 Appendix

### 5.1 Maintenance and Cleaning

#### (1) General Maintenance

Keep the instrument away from the direct sunlight.

#### Caution

Keep sprays, liquids and solvents away from the instrument or probe to avoid damaging the instrument or probe.

#### (2) Cleaning

Check the instrument frequently according to the operating condition. Follow these steps to clean the external surface of the instrument:

Please use a soft cloth to wipe the dust outside the instrument.

When cleaning the LCD screen, please pay attention and protect the transparent LCD screen.

Please disconnect the electronic load, then wipe the instrument with a damp but not dripping soft cloth. Do not use any abrasive chemical cleaning agent on the instrument or probes.

#### Warning

Please confirm that the instrument is completely dry before use, to avoid electrical shorts or even personal injury caused by moisture.