



User's Manual

UTL1000S Series DC Electronic Load

V1.0

December 2025

Foreword

Thank you for choosing this UNI-T instrument. For safe and proper use this instrument, please read this manual carefully, especially the safety instructions section.

After reading this manual, it is recommended to keep the manual in a convenient location, preferably near the device, for future reference.













1. Introduction

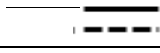

This manual includes safety requirements, installment and the operation of UTL1000S Series DC electronic load.

2. Safety Instructions

This chapter contains information and warnings that must be observed. Ensure that the instrument is operated under the safe conditions. In addition to the safety precautions indicated in this chapter, you must also follow accepted safety procedures.

Safety Precautions	
Warning	Please follow these guidelines to avoid possible electric shock and risk to personal safety.
	Users must adhere to standard safety precautions during the operation, servicing, and maintenance of this device. UNI-T will not be liable for any personal safety and property loss caused by the user's failure following the safety precautions. This device is designed for professional users and responsible organizations for measurement purposes. Do not use this device in any manner not specified by the manufacturer. This device is intended for indoor use only, unless otherwise stated in the product manual.
Safety Statements	
Warning	"Warning" indicates the presence of a hazard. It warns users to pay attention to a certain operation process, operation method or similar. Personal injury or death may occur if the rules in the "Warning" statement are not properly executed or observed. Do not proceed to the next step until you fully understand and meet the conditions stated in the "Warning" statement.
Caution	"Caution" indicates the presence of a hazard. It warns users to pay attention to a certain operation process, operation method or similar. Product damage or loss of important data may occur if the rules in the "Caution" statement are not properly executed or observed. Do not proceed to the next step until you fully understand and meet the conditions stated in the "Caution" statement.
Note	"Note" indicates important information. It reminds users to pay attention to procedures, methods, and conditions, etc. The contents of "Note" should be highlighted if necessary.
Safety Signs	

	Danger	It indicates danger of electric shock, which may cause personal injury or death.
	Warning	It indicates that there are factors you should be cautious of to prevent personal injury or product damage.
	Caution	It indicates danger, which may cause damage to this device or other equipment if you fail to follow a certain procedure or condition. If the "Caution" sign is present, all conditions must be met before you proceed to operation.
	Note	It indicates potential problems, which may cause failure of this device if you fail to follow a certain procedure or condition. If the "Note" sign is present, all conditions must be met before this device will function properly.
	AC	Alternating current of device. Please check the region's voltage range.
	DC	Direct current device. Please check the region's voltage range.
	Grounding	Frame and chassis grounding terminal
	Grounding	Protective grounding terminal
	Grounding	Measurement grounding terminal
	OFF	Main power off
	ON	Main power on
	Power	Standby power supply: When the power switch is turned off, this device is not completely disconnected from the AC power supply.
CAT I		Secondary electrical circuit connected to wall sockets through transformers or similar equipment, such as electronic instruments and electronic equipment; electronic equipment with protective measures, and any high-voltage and low-voltage circuits, such as the copier in the office.
CAT II		Primary electrical circuit of the electrical equipment connected to the indoor socket via the power cord, such as mobile tools, home appliances, etc. Household appliances, portable tools (e.g., electric drill), household sockets, sockets more than 10 meters away from CAT III circuit or sockets more than 20 meters away from CAT IV circuit.
CAT III		Primary circuit of large equipment directly connected to the distribution board and circuit between the distribution board and the socket (three-phase distributor circuit includes a single commercial lighting circuit). Fixed equipment, such as multi-phase motor and multi-phase fuse box; lighting equipment and lines inside large buildings; machine tools and power distribution boards at industrial sites (workshops).
CAT IV		Three-phase public power unit and outdoor power supply line equipment. Equipment designed to "initial connection," such as power distribution system of power station, power instrument, front-end overload protection, and any outdoor transmission line.
	Certification	Comply with European Union standards
	Certification	UKCA indicates a registered trademark of United Kingdom.

	Certification	Conforms to UL STD 61010-1 and 61010-2-030. Certified to CSA STD C22.2 No.61010-1 and 61010-2-030.
	Waste	Do not place equipment and accessories in the trash. Items must be properly disposed of in accordance with local regulations.
	EEUP	This environment-friendly use period (EFUP) mark indicates that dangerous or toxic substances will not leak or cause damage within this indicated time period. The environmentally friendly use period of this product is 40 years, during which it can be used safely. Upon expiration of this period, it should enter the recycling system.
Safety Requirements		
Warning		
Preparation before use		<p>Please connect this device to AC power supply with the power cable provided.</p> <p>The AC input voltage of the line reaches the rated value of this device. See the product manual for specific rated value.</p> <p>The line voltage switch of this device matches the line voltage.</p> <p>The line voltage of the line fuse of this device is correct.</p> <p>This device is not intended for measuring the main circuit.</p>
Check all terminal rated values		Please check all rated values and marking instructions on the product to avoid fire and the impact of excessive current. Please consult the product manual for detailed rated values before connection.
Use the power cord properly		You can only use the special power cord for the instrument approved by the local and state standards. Please check whether the insulation layer of the cord is damaged, or the cord is exposed, and test whether the cord is conductive. If the cord is damaged, please replace it before using the instrument.
Instrument Grounding		To avoid electric shock, the grounding conductor must be connected to the ground. This product is grounded through the grounding conductor of the power supply. Please be sure to ground this product before it is powered on.
AC power supply		Please use the AC power supply specified for this device. Please use the power cord approved by your country and confirm that the insulation layer is not damaged.
Electrostatic prevention		This device may be damaged by static electricity, so it should be tested in the anti-static area if possible. Before the power cable is connected to this device, the internal and external conductors should be grounded briefly to release static electricity. The protection grade of this device is 4 kV for contact discharge and 8 kV for air discharge.
Measurement accessories		Measurement accessories designated as lower-grade, which are not applicable to main power supply measurement, CAT II, CAT III, or CAT IV circuit measurement. Probe subassemblies and accessories within the range of IEC 61010-031 and current sensors within the range of IEC 61010-2-032 can meet its requirements.
Use the input / output port of this device properly		Please use the input / output ports provided by this device in a proper manner. Do not load any input signal at the output port of this device. Do not load any signal that does not reach the rated value at the input port of this device. The probe or other connection accessories should be effectively grounded to avoid product damage or abnormal function. Please refer to the product manual for the rated value of the input / output port of this device.
Power fuse		Please use a power fuse of exact specification. If the fuse needs to be replaced, it must be replaced with another one that meets the specified specifications by the maintenance personnel authorized by UNI-T.
Disassembly and cleaning		There are no components available for operators inside. Do not remove the protective cover.

	Qualified personnel must conduct maintenance.
Service environment	This device should be used indoors in a clean and dry environment with ambient temperature from 0 °C to +40 °C. Do not use this device in explosive, dusty, or high humidity conditions.
Do not operate in humid environment	Do not use this device in a humid environment to avoid the risk of internal short circuit or electric shock.
Do not operate in flammable and explosive environment	Do not use this device in a flammable and explosive environment to avoid product damage or personal injury.
Caution	
Abnormality	If this device may be faulty, please contact the authorized maintenance personnel of UNI-T for testing. Any maintenance, adjustment or parts replacement must be done by the relevant personnel of UNI-T.
Cooling	Do not block the ventilation holes at the side and back of this device. Do not allow any external objects to enter this device via ventilation holes. Please ensure adequate ventilation and leave a gap of at least 15 cm on both sides, front and back of this device.
Safe transportation	Please transport this device safely to prevent it from sliding, which may damage the buttons, knobs, or interfaces on the instrument panel.
Proper ventilation	Insufficient ventilation will cause the device temperature to rise, thus causing damage to this device. Please keep proper ventilation during use, and regularly check the vents and fans.
Keep clean and dry	Please take actions to avoid dust or moisture in the air affecting the performance of this device. Please keep the product surface clean and dry.
Note	
Calibration	The recommended calibration period is one year. Calibration should only be conducted by qualified personnel.

3. Product Introduction

UTL1000S Series (UTL1020S/UTL1020S-E/UTL1040S/UTL1040S-E) DC electronic load are a new generation of intelligent, large-screen and cost-effective electronic loads. The synchronizing sampling is up to 500 kHz, with high-performance DSP processing, built-in self-adaptive voltage and current waveform display, convenient for transient testing and multi-faceted intelligent simulation and analysis. Fast, efficient, visualized LIST programmable automated test modes for most R&D and test needs.

3.1 Measurement Application

Automatic application: power, charger, driver, batter

Serial connection application: overcurrent test, programmable constant current, 5 1/2 digit ampere meter, current waveform detection

Other applications: LED simulation, battery simulation, intelligent and programmable automated test

3.2 Accuracy of Instrument

Series	UTL1000S Series				
Model	UTL1020S		UTL1020S-E		
Display Screen	LCD		LCD		
Rated value 0~40°C	Input voltage	0~15V	0~150V	0~15V	0~150V
	Input current	0~3A	0~30A	0~3A	0~30A
	Input power	200W		200W	
	Minimum of operating voltage	1.4±0.1V at 30A		1.4±0.1V at 30A	
CV (Constant Voltage) mode	Range	0.1~150V		0.1~150V	
	Resolution	1mV		1mV	
	Accuracy	± (0.03%+0.05%FS)		± (0.03%+0.05%FS)	
CC (Constant Current) mode	Range	0~3A	0~30A	0~3A	0~30A
	Resolution	0.01mA	0.1mA	0.1mA	1mA
	Accuracy	± (0.03%+0.05%FS)		± (0.03%+0.05%FS)	
CR (Constant Resistance) mode	Range	0.05Ω~10kΩ		0.05Ω~10kΩ	
	Resolution	16bit		16bit	
	Accuracy	(0.1+0.01R)%		(0.1+0.01R)%	
CP (Constant Power) mode	Range	200W		200W	
	Resolution	10mW		10mW	
	Accuracy	± (0.1%+0.1%FS)		± (0.1%+0.1%FS)	
Dynamic mode	T1&T2	10μs~50s/Res:1μs		10μs~50s/Res:1μs	
	Accuracy	1μs/1ms±100ppm		1μs/1ms±100ppm	

	Rising/falling slope	0.0006A/ μ s~3A/ μ s		0.0006A/ μ s~3A/ μ s	
	Minimum of rising time	10 μ s		10 μ s	
CC/CP Readback voltage	Range	0~15V	0~150V	0~15V	0~150V
	Resolution	0.01mV	0.1mV	0.1mV	1mV
	Accuracy	\pm (0.02%+0.3%FS)		\pm (0.02%+0.3%FS)	
CV/CR Readback voltage	Range	0~150V		0~150V	
	Resolution	0.1mV		0.1mV	
	Accuracy	\pm (0.02%+0.3%FS)		\pm (0.02%+0.3%FS)	
Readback current	Range	0~3A	0~30A	0~3A	0~30A
	Resolution	0.01mA	0.1mA	0.1mA	1mA
	Accuracy	\pm (0.03%+0.05%FS)		\pm (0.03%+0.05%FS)	
Readback power	Range	200W		200W	
	Resolution	10mW		10mW	
	Accuracy	\pm (0.1%+0.1%FS)		\pm (0.1%+0.1%FS)	
Overpower protection		Delay protection when \geq 202W, Immediately protection when \geq 220W		Delay protection when \geq 202W, Immediately protection when \geq 220W	
Overcurrent protection		Delay protection when \geq 30.3A, Immediately protection when \geq 33A		Delay protection when \geq 30.3A, Immediately protection when \geq 33A	
Overvoltage protection		Delay protection when \geq 152V, Immediately protection when \geq 165V		Delay protection when \geq 152V, Immediately protection when \geq 165V	
Over-temperature protection		\geq 85 $^{\circ}$ C		\geq 85 $^{\circ}$ C	
Short Circuit	Current (CC)	\geq 3A	\geq 30A	\geq 3A	\geq 30A
	Voltage (CV)	0V	0V	0V	0V
	Resistance (CR)	60m Ω	60m Ω	60m Ω	60m Ω
Ripple display		√		√	
Waveform record		√		√	
Test mode		15 test modes: CC, CV, CR, CP, dynamic, OVP, time, OCP, CR-LED, battery, automatic list, short circuit, load effect, combination, list		15 test modes: CC, CV, CR, CP, dynamic, OVP, time, OCP, CR-LED, battery, automatic list, short circuit, load effect, combination, list	
Resistance of input terminal		300K Ω		300K Ω	
Fuse specification		0.5A(110V)/0.25A(220V)		0.5A(110V)/0.25A(220V)	
Communication interface		RS232		RS232	
Protocol		SCPI		SCPI	
Data acquisition software		√		√	
Standard accessory		Power cord		Power cord	
Power requirement		110V/220V Frequency 50/60Hz		110V/220V Frequency 50/60Hz	
Size mm (WxHxD)		215*88*372		215*88*372	
Net Weight (kg)		3.73		3.73	

Series		UTL1000S Series			
Model		UTL1040S		UTL1040S-E	
Display Screen		LCD		LCD	
Rated value 0~40°C	Input voltage	0~15V	0~150V	0~15V	0~150V
	Input current	0~3A	0~30A	0~3A	0~30A
	Input power	400W		400W	
	Minimum of operating voltage	1.4V±0.1V at 30A		1.4V±0.1V at 30A	
CV (Constant Voltage) mode	Range	0.1~150V		0.1~150V	
	Resolution	1mV		1mV	
	Accuracy	± (0.03%+0.05%FS)		± (0.03%+0.05%FS)	
CC (Constant Current) mode	Range	0~3A	0~30A	0~3A	0~30A
	Resolution	0.01mA	0.1mA	0.1mA	1mA
	Accuracy	± (0.03%+0.05%FS)		± (0.03%+0.05%FS)	
CR (Constant Resistance) mode	Range	0.05Ω~10kΩ		0.05Ω~10kΩ	
	Resolution	16bit		16bit	
	Accuracy	(0.1+0.01R)%		(0.1+0.01R)%	
CP (Constant Power) mode	Range	400W		400W	
	Resolution	10mW		10mW	
	Accuracy	± (0.1%+0.1%FS)		± (0.1%+0.1%FS)	
Dynamic mode	T1&T2	10μs~50s/Res:1μs		10μs~50s/Res:1μs	
	Accuracy	1μs/1ms±100ppm		1μs/1ms±100ppm	
	Rising/falling slope	0.0006A/μs~3A/μs		0.0006A/μs~3A/μs	
	Minimum of rising time	10μs		10μs	
CC/CP Readback voltage	Range	0~15V	0~150V	0~15V	0~150V
	Resolution	0.01mV	0.1mV	0.1mV	1mV
	Accuracy	± (0.02%+0.3%FS)		± (0.02%+0.3%FS)	
CV/CR Readback voltage	Range	0~150V		0~150V	
	Resolution	0.1mV		0.1mV	
	Accuracy	± (0.02%+0.3%FS)		± (0.02%+0.3%FS)	
Readback current	Range	0~3A	0~30A	0~3A	0~30A
	Resolution	0.01mA	0.1mA	0.1mA	1mA
	Accuracy	± (0.03%+0.05%FS)		± (0.03%+0.05%FS)	
Readback power	Range	400W		400W	
	Resolution	10mW		10mW	
	Accuracy	± (0.1%+0.1%FS)		± (0.1%+0.1%FS)	
Overpower protection	Delay protection when ≥404W, Immediately protection when ≥440 W		Delay protection when ≥404W, Immediately protection when ≥440 W		

Overcurrent protection	Delay protection when $\geq 30.3A$, Immediately protection when $\geq 33A$		Delay protection when $\geq 30.3A$, Immediately protection when $\geq 33A$		
Overvoltage protection	Delay protection when $\geq 152V$, Immediately protection when $\geq 165V$		Delay protection when $\geq 152V$, Immediately protection when $\geq 165V$		
Over-temperature protection	$\geq 85^{\circ}C$		$\geq 85^{\circ}C$		
Short Circuit	Current (CC)	$\geq 3A$	$\geq 30A$	$\geq 3A$	$\geq 30A$
	Voltage (CV)	0V	0V	0V	0V
	Resistance (CR)	50m Ω	50m Ω	50m Ω	50m Ω
Ripple display	√		√		
Waveform record	√		√		
Test mode	15 test modes: CC, CV, CR, CP, dynamic, OVP, time, OCP, CR-LED, battery, automatic list, short circuit, load effect, combination, list		15 test modes: CC, CV, CR, CP, dynamic, OVP, time, OCP, CR-LED, battery, automatic list, short circuit, load effect, combination, list		
Resistance of input terminal	300K Ω		300K Ω		
Fuse specification	0.5A(110V)/0.25A(220V)		0.5A(110V)/0.25A(220V)		
Communication interface	RS232		RS232		
Protocol	SCPI		SCPI		
Data acquisition software	√		√		
Standard accessory	Power cord		Power cord		
Power requirement	110V/220V Frequency 50/60Hz		110V/220V Frequency 50/60Hz		
Size mm (WxHxD)	215*88*372		215*88*372		
Net Weight (kg)	4.49		4.49		

Accuracy temperature range: $25 \pm 5^{\circ}C$

Calibration period: 1 time/year

3.3 Key Features

- 4.3 inch LCD, all the test results at a glance
- Synchronous sampling of 500 kHz, 10Hz, 10uA, 0.1 mV stable resolution output
- Dynamic mode (DYNA) of 50 kHz pull load, the waveform of current and voltage peak can be observed directly, Vpp, Ipp measurement
- Realistic simulation of LED function
- Basic mode: CC, CV, CR and CP
- Supports OCP test and maximum power test
- Supports time measurement (TIME)
- Supports OVP test
- Supports intelligent and programmable automated list test (LIST)

4. Product Overview

4.1 Front Panel

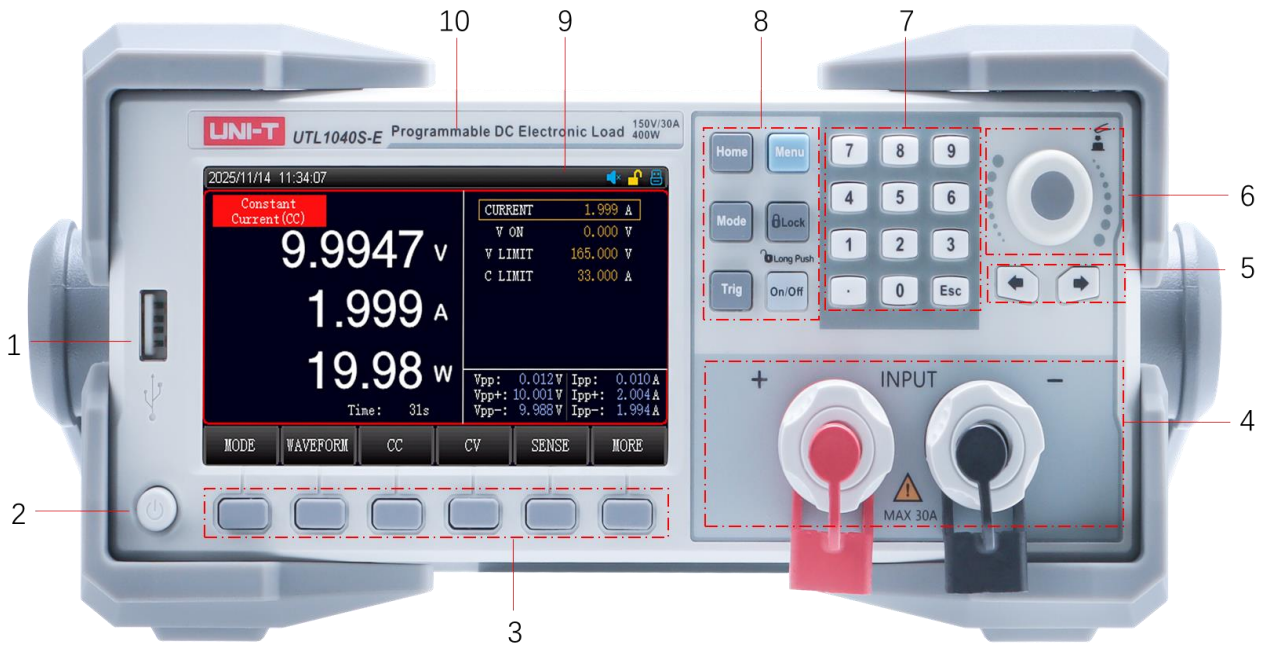
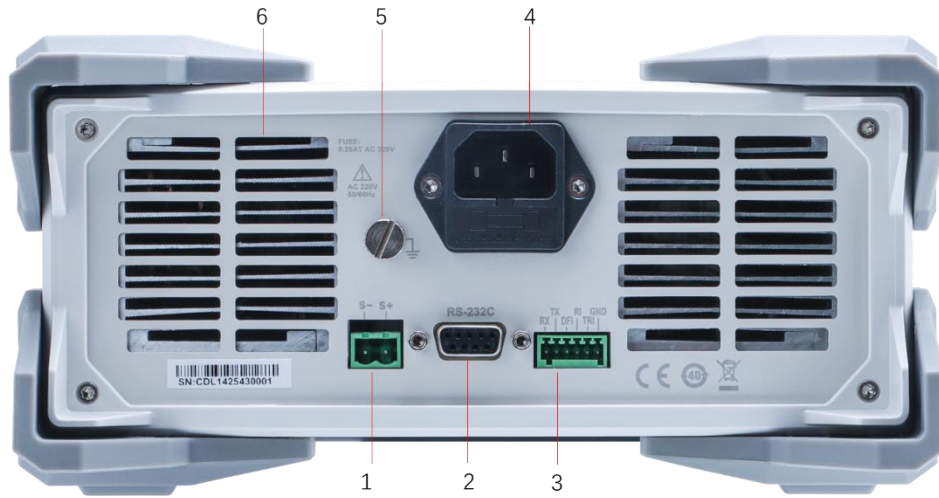

Figure 4-1 Front Panel

No.	Name	Description
1	USB HOST	Connect USB to save and load the file, screenshot and save measured data
2	Power switch	Turn on/off the electronic load
3	Screen function softkey	Six softkeys to select and control parameters, each with its own function
4	Test terminal	Connect on-load power To avoid damage to the device, do not connect in reverse.
5	Arrow key	Move the cursor
6	Rotary knob	Move the cursor or adjust the numeric value of selected parameter
7	Numerical keyboard	Enter number Esc: exit the current page
8	Quick function key	Home: back to home page Mode: select a test mode Lock: lock key (long press to unlock/short press to lock) Menu: enter the system setting Trig: trigger control /short-circuit test (SHORT) On/Off: control the input state of load ON/OFF
9	Screen	Display setting and measurement interface
10	Nameplate	Brand and model

4.2 Rear Panel



No.	Name	Description
1	SENSE terminal	Sampling measure the accurate voltage at the output terminal of DUT
2	RS-232C interface	RS232 communication
3	HANDLER interface	External trigger
4	Power socket	AC power supply (built-in fuse)
5	Grounding terminal	Ground connection
6	Heat emission hole	Cooling

Figure 4-2 Rear Panel

No.	Name	Description
1	Heat emission hole	Cooling
2	I Monitor	Current monitor port
3	Power Socket	AC power supply (built-in fuse)
4	AC 220/110 V power switch	Voltage switch of AC power supply
5	HANDLER interface	External trigger
6	RS-232C interface	RS232 communication
7	Grounding Terminal	Ground connection

5. Inspection and Installation

5.1 Packing List

Please inspect the instrument before using

1. Check whether the appearance is damaged, scratched or has other defects;
2. Check with packing list to confirm that accessories has no loss.

If the instrument is broken or the accessory is missing, please contact with UNI-T sale department or the distributor.

5.2 Power Requirements

This instrument is designed for use with Class II overvoltage. Do not use the instrument with class III and IV overvoltage.

Before switching on the power supply, check that the supply voltage and fuse match the voltage on the rear panel of the instrument.

Parameter	Requirements
Voltage	AC 220/110($\pm 10\%$)V
Frequency	50/60 HZ
Fuse	AC 220 V input voltage: 250 V/0.25AT AC 110 V input voltage: 250 V/0.5AT

- The factory supplies three-core power cord, please make sure that power ground of three phase socket is reliably connect to ground before use.
- Please remove the external power cord before replace the fuse, open the fuse socket slot under the power supply interface, take out the old fuse and replace the new fuse, after that the instrument can be used normally.



Warning: Do not use the power cord with sings of any damage to avoid danger!
Please use the fuse that meets the specifications, as shown in the table above.

5.3 Operating Environment

The operating environment requirements of UTL1000S series is as follows.

When the electronic load is loading, the speed rate of ventilation fans will automatically change with the temperature of cooling fan.

Operating Environment	Environmental Requirements
Humidity	20 %~80 % (non-condensation)
Temperature	0 °C~40 °C
Storage Temperature	-20 °C~60 °C
Altitude	≤ 2000 meters
Pollution Degree	2
Indoor or outdoor use	For indoor use only

5.4 Cleaning

To prevent from the risk of electric shock, please pull out the power cord before cleaning.

Please use a clean and damp cloth to clean the cover and panel. No water shall enter the instrument.

Do not clean the inside of the instrument.



Warning: Do not use solvents (alcohol or gasoline) to clean the instrument.

5.5 Handle

Handle is adjustable and can adjust to four positions, hold two sides of the handle to pull or rotate as shown in the following figure.

Figure 5-1 Original Position

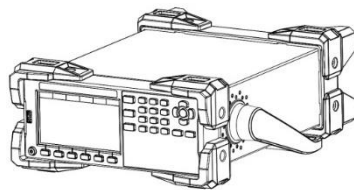

Figure 5-2 Test Position

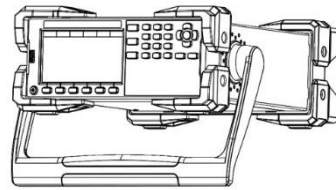

Figure 5-3 Remove Handle

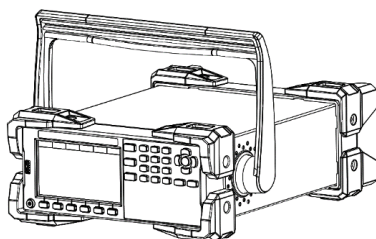
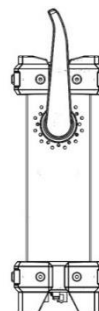

Figure 5-4 Lift Position



5.6 Routine Inspection

To avoid the accident, please checking the instrument before using.

1. The instrument's input power should conform to the specification and the power configuration should be correct.
2. The instrument should be securely connected to the ground.
3. DUT is sound, no crack, break and damage.

6. Measurement Display Page

6.1 Power Up

The correct self-inspection of electronic load is as follows.

1. Press the power switch on the front panel to power up the electronic load. The screen shows the progress bar of the current self-inspection.
2. After the initialization, the screen displays the current measurement state. If the boot-up mode is set, the instrument will directly enter the preset measurement mode.

When the self-inspection is finished, it means that the instrument is meet the factory standard. The user can use the product normally.



Note: Before using the electronic load, the user should fully understand the safety requirements.

Warning: Please make sure that the power voltage is matched with the utility power.

Otherwise, the instrument will be damaged.

The main power plug should connect to the power socket with protective ground. Do not use a wire board without protective ground.

6.2 Install Connection Wire

The electronic load connects the DUT via the "+" and "-" terminal panel. Before connecting, the user should note that the core of cable should be suitable and the polarity (positive/negative) should be correctly connected. The connection wire must be thick enough to reduce the voltage drop on the line. Due to the large voltage drop, it is suggested that use the **Sense** terminal of the electronic load for compensation to

ensure the measurement accuracy.

Test Lead Specifications

The test leads required for connecting to the device under test are not included as standard accessories with this instrument. Please purchase the separately sold red and black test leads based on the maximum current value. For the specifications of the test leads and the maximum current they can withstand, refer to the optional accessories section in the datasheet.

Terminal Introduction

The front panel of the UTL1000S series loads includes the following terminals. The terminal at position (A) has a maximum rated current of 120A, while the terminal at position (B) supports standard banana plugs but can only output a maximum current of 10A.

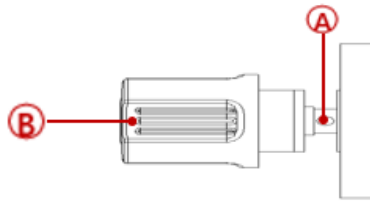

Caution: Before connecting, please make sure that the polarity of input terminal is correctly connected, otherwise, the device may be damaged.

6.3 Screen Display



LCD will divided into several areas to display information when enter the measurement mode. Take CC mode as an example, as shown in the following figure.



6.3.1 Measurement Interface

No.	Name	Description
1	State	Displays the current mode and state
2	Time	Displays the current system date and time
3	System	Displays USB, remote sense, short-circuit test, sound, key lock and remote control
4	Parameter	Displays the set parameter
5	Ripple data	Displays the ripple data of voltage/current
6	Function area	Quick function key
7	Parameter on primary screen	Displays the time, running procedure or result data in real time running

6.3.2 State Information

State	Display	Description
Measurement	Mode	Displays the current measurement state or operation mode
Control	Comm	Local/Remote mode
Remote sense	Sense	When it is illuminated, which means the remote sense is enabled.
USB		It indicates that USB is inserted
System time	0000.00.00 00:00	Displays the current system time: year/month/day/time/minute
Alarm		It indicates that the alarm sound is enabled.
Short-circuit	Short	The electronic load is under the short-circuit mode.
ATE Test	ATE	The electronic load is under the ATE test mode.

6.3.3 Running Indicator

The ON/OFF key of UTL1000S series electronic load is equipped with a running indicator. When the electronic load is working, the running indicator of ON/OFF key will be illuminated. The electronic load will stop working when the ON/OFF key is pressed again, and the running indicator of ON/OFF key will be extinguished.

6.4 Screenshot

The instrument has screenshot function. The screenshot function can be used when USB is inserted to the USB interface on the front panel. A USB icon will display on the screen, and long press the rotary knob on the panel, the current screen image will save to USB for later use.

It is recommended that the user use a branded USB (format FAT32, maximum capacity 128G).

6.5 Key Lock

The instrument has a key lock function to prevent the test condition from being changed inadvertently.

Short press the **[Lock]** key on the panel to lock the key.

Long press the **[Lock]** key on the panel for 1s to unlock the key.

When the keyboard is locked, only the **[On/Off]** key and the **[Lock]** key of the instrument can be used.

7. Measurement Setup Page

7.1 Mode and Measurement

The electronic load has four constant test mode, which are CC (constant current), CV (constant voltage), CR (constant resistance) and CP (constant power). In addition, it has 11 kinds of other modes, which are dynamic, OVP, time, OCP, CR-LED, battery, automatic list, short-circuit, load effect, combination and list.

Press the **[Mode]** key to select a mode.

Introduction of mode

Mode Name	Description
CC	No matter how the input voltage changes, the electronic load always consumes the constant current.
CV	The electronic load maintains the input voltage as the set value by changing the current consumption.
CR	The electronic load is equal to a resistance, the input voltage will change with the voltage to maintain a constant resistance.

CP	The electronic load consumes the rated power, the current decreases as the voltage increases, to maintain the constant power.
11 kinds of other modes	Select the mode by using the rotary knob or arrow keys, these mode can meet diversified test requirements.

After enter the constant test mode, the set current, voltage, resistance and power will be displayed on the right side of the screen. These parameter can be changed by using the numerical keyboard or the rotary knob.

When the electronic load is working, time, Vpp (voltage peak-to-peak) and Ipp (current peak-to-peak) will be displayed at the bottom of the screen.

7.1.1 CC (Constant Current) Test

In the CC mode, no matter how the input voltage changes, the electronic load always consumes the constant current.

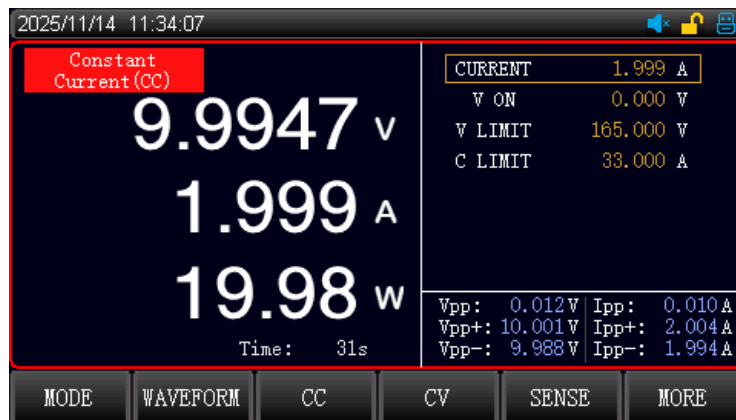

Figure 7-1-1 CC Mode

Operation Steps

1. Select the [Mode] key on the initial interface, and press the [CC] key to enter the <Constant Current> page.
2. Use the rotary knob to move the cursor to the current field, and press the **rotary knob** to change the current field from black to brown, at this point, the current value can be set. Use the keyboard or press the rotary knob to enter the current value and then press the **rotary knob** to confirm. The current field will change from brown to black.
3. The operation step of other parameters are the same as above.
4. The electronic load starts to work when the **ON/OFF** key is pressed, and the indicator will be illuminated. Press the ON/OFF key again, the electronic load will stop working, and the indicator will be extinguished.

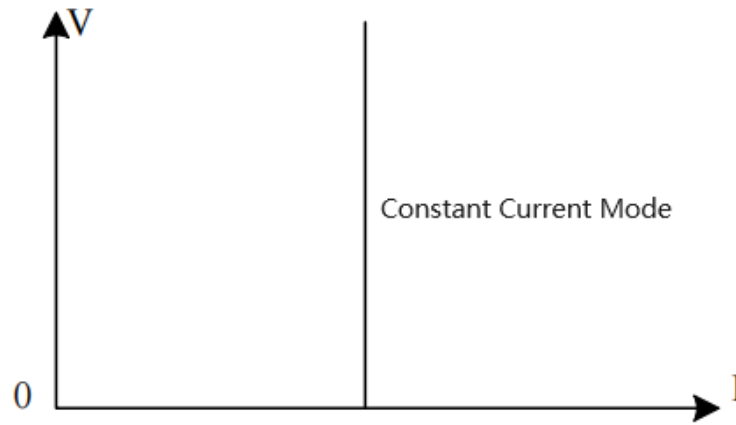

Figure 7-1-2 Voltage-Current Relation in CC Mode

7.1.2 CV (Constant Voltage) Test

In the CV mode, the electronic load maintains the input voltage as the set value by changing the current consumption.

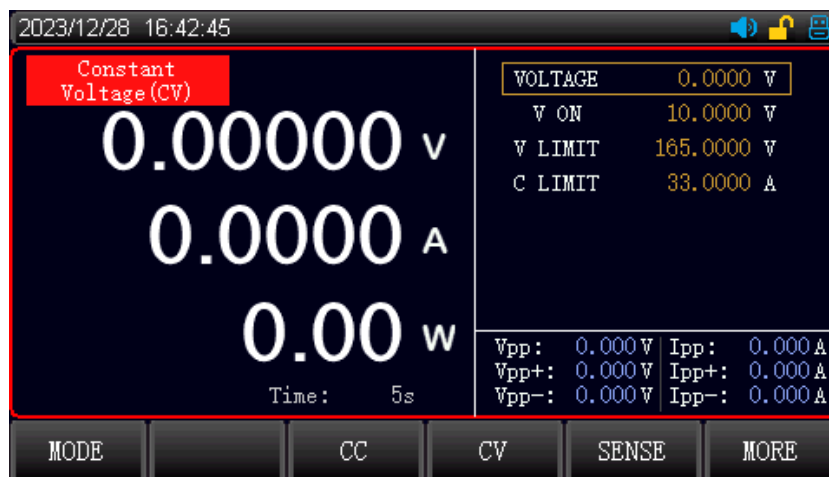

Figure 7-1-3 CV Mode

Operation Steps

1. Select the [Mode] key on the initial interface, and press the [CV] key to enter the <Constant Voltage> page.
2. Use the rotary knob to move the cursor to the voltage field, and press the **rotary knob** to change the voltage field from black to brown, at this point, the voltage value can be set. Use the keyboard or press the rotary knob to enter the voltage value and then press the **rotary knob** to confirm. The voltage field will change from brown to black.
3. The operation step of other parameters are the same as above.

- The electronic load starts to work when the **ON/OFF** key is pressed, and the indicator will be illuminated. Press the **ON/OFF** key again, the electronic load will stop working, and the indicator will be extinguished.

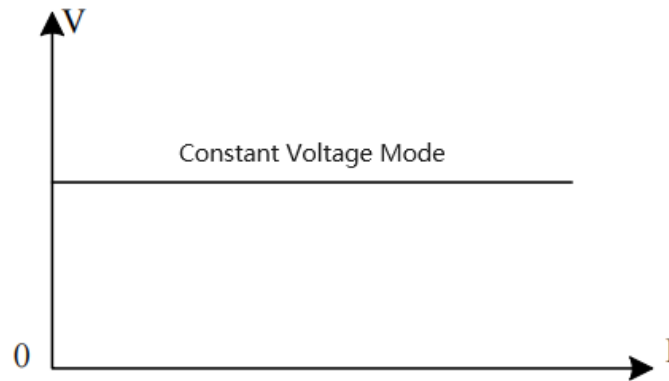

Figure 7-1-4 Voltage-Current Relation in CV Mode

7.1.3 CR (Constant Resistance) Test

In the CR mode, the electronic load is equal to a resistance, the input voltage will change with the voltage to maintain a constant resistance.

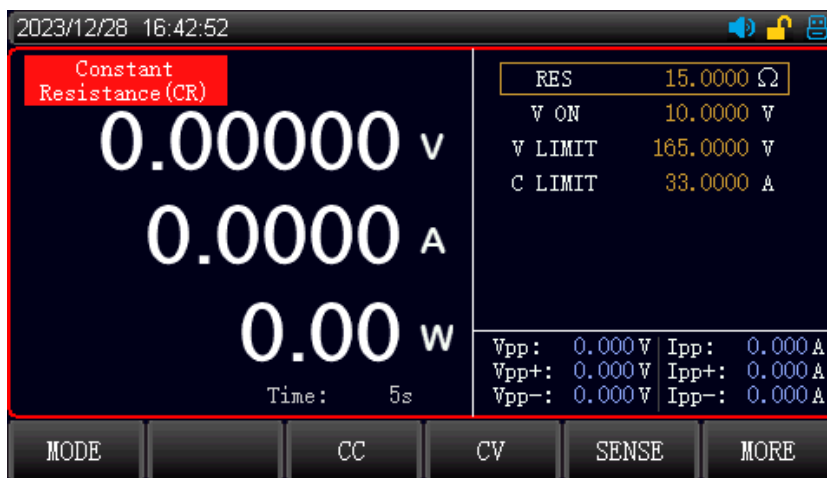

Figure 7-1-5 CR Mode

Operation Steps

- Select the **[Mode]** key on the initial interface, and press the **[CR]** key to enter the <Constant Resistance> page.
- Use the rotary knob to move the cursor to the resistance field, and press the **rotary knob** to change the resistance field from black to brown, at this point, the resistance value can be set. Use the keyboard or press the rotary knob to enter the resistance value and then press the **rotary knob** to confirm. The resistance field will change from brown to black.

- The operation step of other parameters are the same as above.
- The electronic load starts to work when the **ON/OFF** key is pressed, and the indicator will be illuminated. Press the ON/OFF key again, the electronic load will stop working, and the indicator will be extinguished.

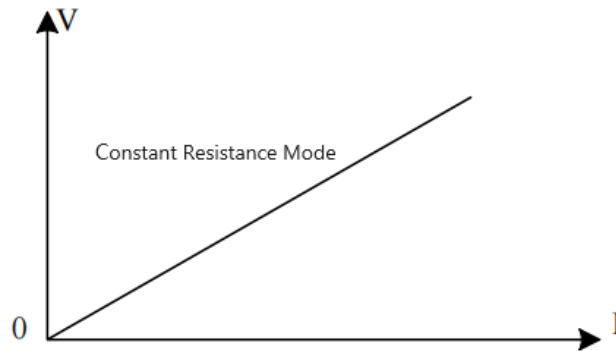

Figure 7-1-6 Voltage-Current Relation in CV Mode in CR Mode

7.1.4 CP (Constant Power) Test

In the CP mode, the electronic load consumes the rated power, the instrument will change the current according to the voltage, to maintain the set power.

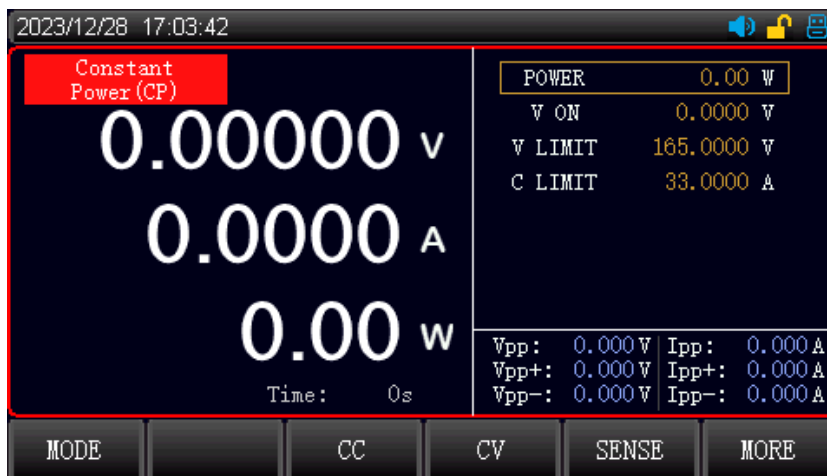

Figure 7-1-7 CP Mode

Operation Steps

- Select the **[Mode]** key on the initial interface, and press the **[CP]** key to enter the <Constant Power (CP)> page.
- Use the rotary knob to move the cursor to the power field, and press the **rotary knob** to change the power field from black to brown, at this point, the power value can be set. Use the keyboard or press

the rotary knob to enter the power value and then press the **rotary knob** to confirm. The power field will change from brown to black.

3. The operation step of other parameters are the same as above.
4. The electronic load starts to work when the **ON/OFF** key is pressed, and the indicator will be illuminated. Press the ON/OFF key again, the electronic load will stop working, and the indicator will be extinguished.

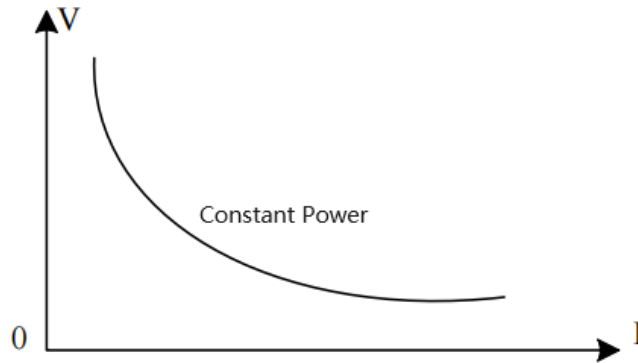

Figure 7-1-8 Voltage-Current Relation in CV Mode in CP Mode

7.2 Other Mode

To meet a variety of test needs, UTL1000S series electronic load provides multiple test modes, which are dynamic test, list test, time test, OCP test, CR-LED test, battery test, OVP test, short circuit test, load effect test and combination test, as shown in Table 4-2.

4-2 Introduction of Other Mode

Other Mode	Description
Dynamic test	Set two different current/voltage values. This allows the electronic load to step through the two levels under test.
Auto list test	Up to 200 steps of load mode, customized step mode and judge the upper/lower limit, memory function for each test group.
Time test	Specifically for the start/fall time test of power switch. Set the start and end values for the load mode, when the voltage of the DUT is stable and then to detect the time from rise to stable.
OCP test	Set the value of overcurrent, overpower and overvoltage, to detect the protection function of the DUT is worked. During the test, the electronic load constantly increases the set load value to detect the protective value of the DUT.
CR-LED test	During the test, the electronic load constantly increases the set load value to detect the protective value of the DUT.

	CR-LED test for LED power supply, it simulates the operating parameter, set the voltage/current of operating point and LED coefficient, so that the performance of LED power can be detected.
Battery test	Three discharge modes: CC/CR/CP Use CC/CR/CP to discharge the DUT's power. The test stops automatically and displays the battery capacity and discharge curve when it reaches the cut-off point.
OVP test	Set the value of overcurrent, overpower and overvoltage, to detect the protection function of the DUT is worked. During the test, the electronic load constantly increases the set load value to detect the protective value of the DUT.
Short test	The electronic load can simulates a short-circuited circuit at the input terminal, it is used to detect whether the protection function of DUT is working when the output terminal of the DUT is short-circuited.
Load effect	Three different loads are loaded according to the set load value and calculate V and Reg (load regulation ratio).
Dual test	The combination test consists of two types of constant mode: CR+CC, CV+CR, CV+CC. It can meet the demands for more constant mode.
List test	List tests are used for simulation of real loads, or for editing complex load waveforms, where the loads are loaded sequentially in order according to the sequence edited in the file.

7.2.1 Dynamic Test

Under the dynamic test, the user can set two constant parameter. The electronic load can switch between the two constant values by setting the operation mode.

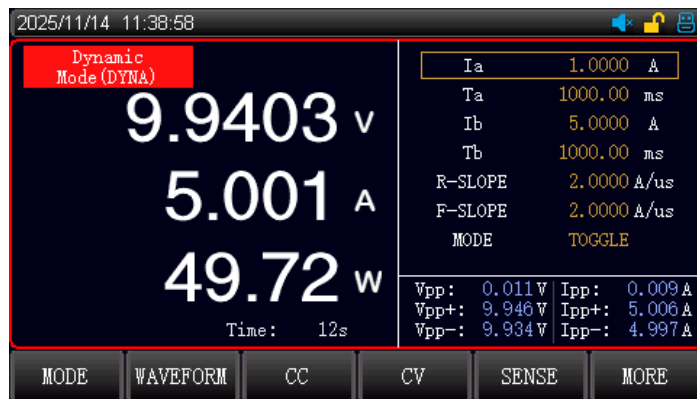

Figure 7-2-1 Dynamic Test Page

Parameter setting of dynamic mode

Dynamic Test	Description
Operation mode	Continuous/pulse/toggle
Ia---Low value	Set the low value

Ta---Time of low range	Set the load time for low range
lb---High value	Set the high value
Tb---Time of high range	Set the load time for high range
R-Slope(Rising slope)	Set the rising slope
F-Slope(Falling slope)	Set the falling slope

Operation Mode

1. Continuous mode: the electronic load will automatically switch continuously between the two set, high and low values. The continuous mode interface is shown in Figure 7-2-2.

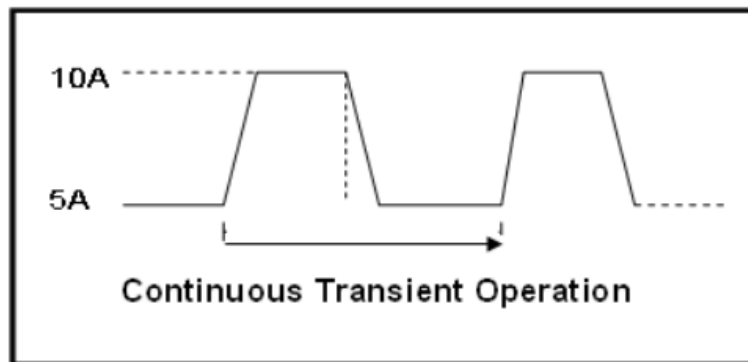

Figure 7-2-2 Continuous Transient Operation

2. Pulse mode: the electronic load uses the low value to load at first, and then the electronic load switches to the high value when it receives a trigger signal for each time. After maintaining the set time, the electronic load switches to the low value. The electronic load only toggles once when it receives a trigger signal for each time, so there's no need to set the time of the low range. The pulse mode interface is shown in Figure 7-2-3.

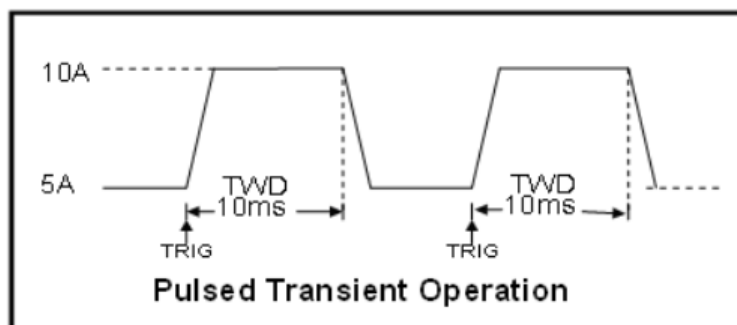

Figure 7-2-3 Pulsed Transient Operation

3. Toggle mode: the electronic load will toggle once between the high and low values for each trigger. At this time, there is no need to set the time for both high and low. And it will only toggle to the other state after each trigger is performed. Toggled transient operation is shown in Figure 7-2-4.

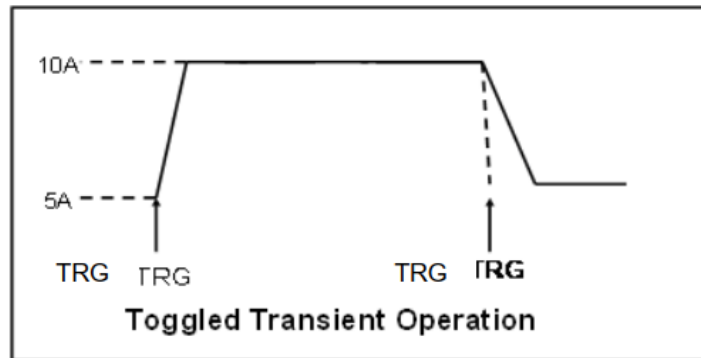

Figure 7-2-4 Toggled Transient Operation

Operation Steps

1. Select the **[Mode]** key on the initial interface, and press the **[MORE]** key to select the **[DYNAMIC]** key to enter the <Dynamic Test (DYNA)> page.
2. Use the rotary knob to move the cursor to the field to be set, and press the **rotary knob** to change the field area from black to brown, at this point, the field area can be set. Use the keyboard or press the rotary knob to enter the set value and then press the **rotary knob** to confirm. The field area will change from brown to black.
3. The operation step of other parameters are the same as above.
4. The electronic load starts to work when the **ON/OFF** key is pressed, and the indicator will be illuminated. Press the **ON/OFF** key again, the electronic load will stop working, and the indicator will be extinguished.



Note: If the voltage/current is set as low range, the alarm will be triggered when the electronic load detects the voltage/current value over the low range. A hint "The range is faulty" will be displayed. The user can adjust the voltage/current range according to the actual condition, the parameter setting can refer to 5.2 Power Requirement.

7.2.2 OVP Test

The OVP test can capture the peak of input voltage and the entire drop process after the protection is enabled. When the voltage drops to the set trigger voltage, the electronic load will record the time from the highest point to the trigger point, the time is the overvoltage protection time of the measured voltage.



Figure 7-2-5 OVP Mode Page

Parameter setting of OVP

Parameter	Description
V TRIG(Trigger voltage)	Set the voltage of trigger point

Select the [MORE] key and then select [OVP] to set the trigger voltage, press ON/OFF key to run the OVP test. The overvoltage protection function of the power supply is triggered by increasing the output voltage of the power supply. The load captures the peak value of the voltage and the falling edge and starts to record time, and starts triggering at the set trigger voltage, the electronic load records the voltage at the peak point and calculates the time from the peak to the trigger point. After the test is finished, the electronic load displays the measured OVP (voltage peak) and Tovp (protection time). The measurement accuracy of protection time is 1 ms.

Operation Steps

1. Select the [Mode] key on the initial interface, and press the [MORE] key to select the [OVP] key to enter the <Overvoltage Protection (OVP)> page.
2. Use the rotary knob to move the cursor to the field to be set, and press the **rotary knob** to change the field area from black to brown, at this point, the field area can be set. Use the keyboard or press the

rotary knob to enter the set value and then press the **rotary knob** to confirm. The field area will change from brown to black.

3. The operation step of other parameters are the same as above.
4. The electronic load starts to work when the **ON/OFF** key is pressed, and the indicator will be illuminated. Press the ON/OFF key again, the electronic load will stop working, and the indicator will be extinguished.

7.2.3 Time Test

In the preset condition, the time test is to detect the measured power from a voltage rises/falls to another voltage. After the test is finished, the electronic load displays the interval of two time points. The accuracy of time measurement is 1ms.

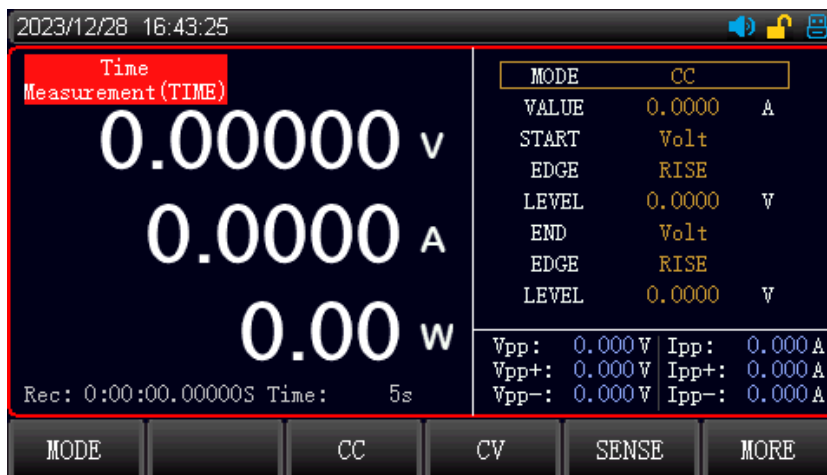

Figure 7-2-6 Time Test Page

Parameter setting of time test

Parameter	Description
Mode	Load mode(CC/CV/CR/CP/OFF)
Value (Load value)	Set the load value for the selected mode
Start (Start trigger)	Set the start condition (Volt/Curr/external/VoltEX/CurrEX)
Edge (Start edge)	Set the start trigger mode (rise/fall)
Level (Start trigger value)	Set the stop condition (Volt/Curr/external/VoltEX/CurrEX)
Stop (Stop trigger)	Set the stop condition (voltage/current/external)
Edge (Stop edge)	Set the stop trigger mode (rise/fall)
Level (Stop trigger value)	Set the stop trigger value

Before the time test, the load mode, load value, start/stop condition, trigger mode and start/stop value of the electronic load should be preset. During the time test, the electronic load will be loaded according to the preset setting, the electronic load starts time record; when it runs to the stop trigger condition, the electronic load stops time record and display the measured time.

The time test mode simulates the oscilloscope's rising voltage rate test, which can be widely used in the time test of power switch start-up.

Operation Steps

1. Select the **[Mode]** key on the initial interface, and press the **[MORE]** key to select the **[TIME]** key to enter the <Time Measurement (TIME)> page.
2. Use the rotary knob to move the cursor to the field to be set, and press the **rotary knob** to change the field area from black to brown, at this point, the field area can be set. Use the keyboard or press the rotary knob to enter the set value and then press the **rotary knob** to confirm. The field area will change from brown to black.
3. The operation step of other parameters are the same as above.
4. The electronic load starts to work when the **ON/OFF** key is pressed, and the indicator will be illuminated. Press the ON/OFF key again, the electronic load will stop working, and the indicator will be extinguished.
5. VoltEx/CurrEx conditional test time result shown as below:

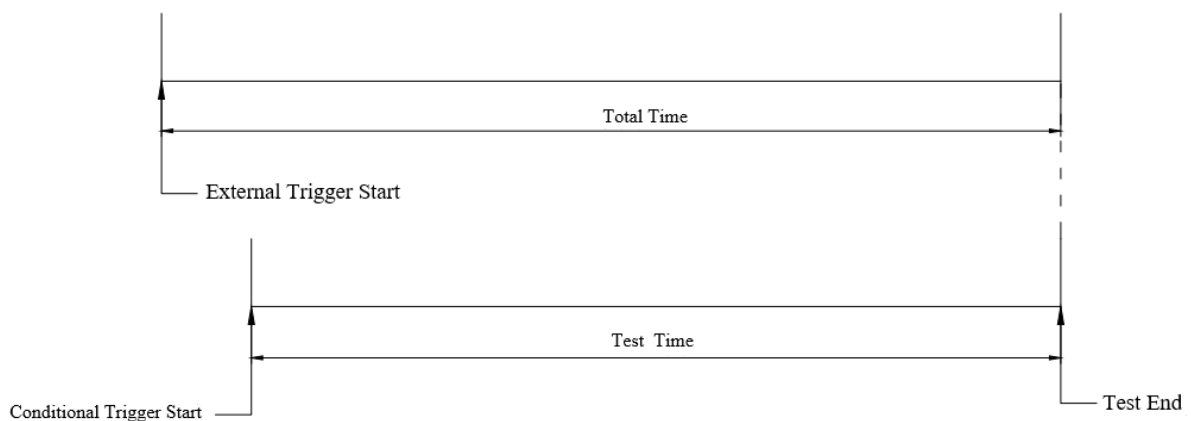

7.2.4 OCP Test

The overcurrent protection test is used to detect whether the OCP function is worked. It can test the OCP of the DUT.

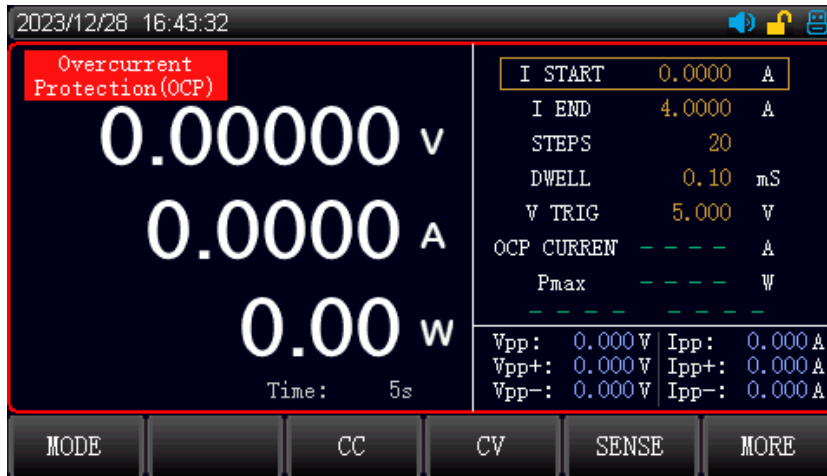

Figure 7-2-7 OCP Mode Page

Parameter setting of OCP

Parameter	Description
I Start (Start current)	Set the start value for this test mode
I End (Cut-off current)	Set the maximum cut-off value for this test mode
Steps	Set the number of test for this test mode
Dwell (Step time)	Set the time interval for each step
V Trig (Trigger voltage)	Set the minimum voltage for cut-off point

In the OCP mode, the user can set the start current, single-step time and test step to increase the load value. The OCP test will stop when it reaches to the cut-off point or detects the protective point of the DUT.

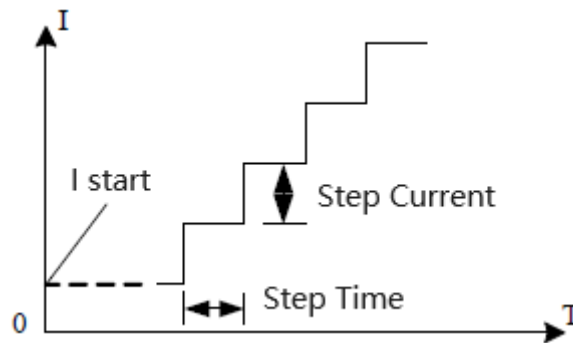

Figure 7-2-8 OCP Test Mode

Description of OCP test mode

As the overload test mode will constantly increase the output power of the DUT, please enter a proper load during the test to avoid damage to the power of the DUT.

After the test is completed, the electronic load displays the time of this test and the current/power of peak point.

Test result of OCP test

When the test result is lower than the cut-off value, it detects the OCP is qualified.

When the test result is greater than the cut-off value, it detects the OCP is unqualified.

Operation Steps

1. Select the **[Mode]** key on the initial interface, and press the **[MORE]** key to select the **[OCP]** key to enter the <Overcurrent Protection (OCP)> page.
2. Use the rotary knob to move the cursor to the field to be set, and press the **rotary knob** to change the field area from black to brown, at this point, the field area can be set. Use the keyboard or press the rotary knob to enter the set value and then press the **rotary knob** to confirm. The field area will change from brown to black.
3. The operation step of other parameters are the same as above.
4. The electronic load starts to work when the **ON/OFF** key is pressed, and the indicator will be illuminated. Press the ON/OFF key again, the electronic load will stop working, and the indicator will be extinguished.

7.2.5 CR-LED Test

CR-LED test is a test mode for LED power supply. The LED operating principle can be simulated by simulating the LED break-over voltage and operating current. This test ensures that the test voltage and current in a normal stable range, avoiding the constant resistance discharge causing oscillation and other unstable conditions, so as to better check the actual LED driver power supply with load conditions.

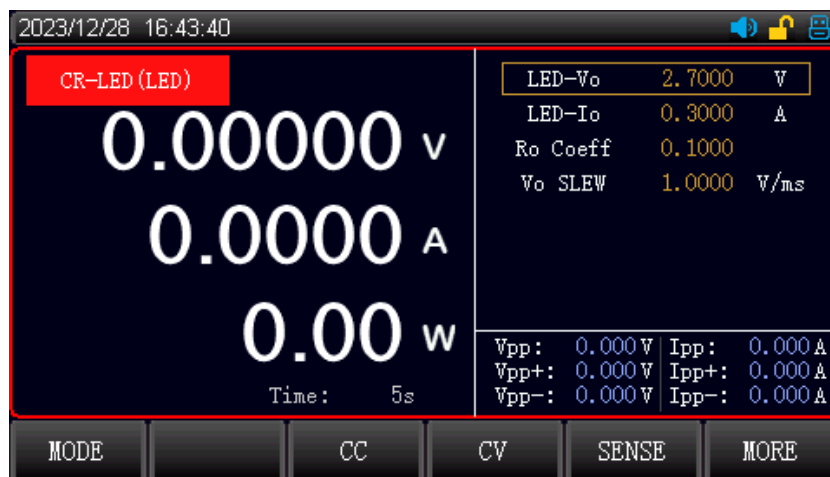

Figure 7-2-9 CR-LED Mode Interface

Parameter setting of CR-LED

Parameter	Description
LED-V _o (Operating voltage)	The operating voltage under LED power rated current

LED-Io (Operating current)	LED power rated output current
Rd Coeff (LED coefficient)	Rd of LED (range: 0.1-0.4)
Vo Slew (Voltage rate)	Transform rate of voltage

CR-LED test is mainly used to test LED power supply. By taking into account the diode conduction voltage factors, the operating principle of the diode is more accurately simulated, allowing the test voltage and current to reach a normal stable value.

Operation Steps

1. Select the **[Mode]** key on the initial interface, and press the **[MORE]** key to select the **[CR-LED]** key to enter the <CR-LED> page.
2. Use the rotary knob to move the cursor to the field to be set, and press the **rotary knob** to change the field area from black to brown, at this point, the field area can be set. Use the keyboard or press the rotary knob to enter the set value and then press the **rotary knob** to confirm. The field area will change from brown to black.
3. The operation step of other parameters are the same as above.
4. The electronic load starts to work when the **ON/OFF** key is pressed, and the indicator will be illuminated. Press the ON/OFF key again, the electronic load will stop working, and the indicator will be extinguished.

7.2.6 Battery Test

Battery test is used to detect the battery capacity. Battery capacity is an important index of battery, it reflects the using time and reliability of battery, so this test is necessary.

During the battery test, the voltage will decreasing with the increasing of discharge time, so it need to set the cut-off voltage, the test will stop when it reaches the cut-off voltage. When the battery is being charged, the voltage will constantly rise with the charge time, so the cut-off voltage for full charge must be set. The test will stop when it reaches the cut-off voltage (the charge test should use the SENSE terminal to collect the voltage).

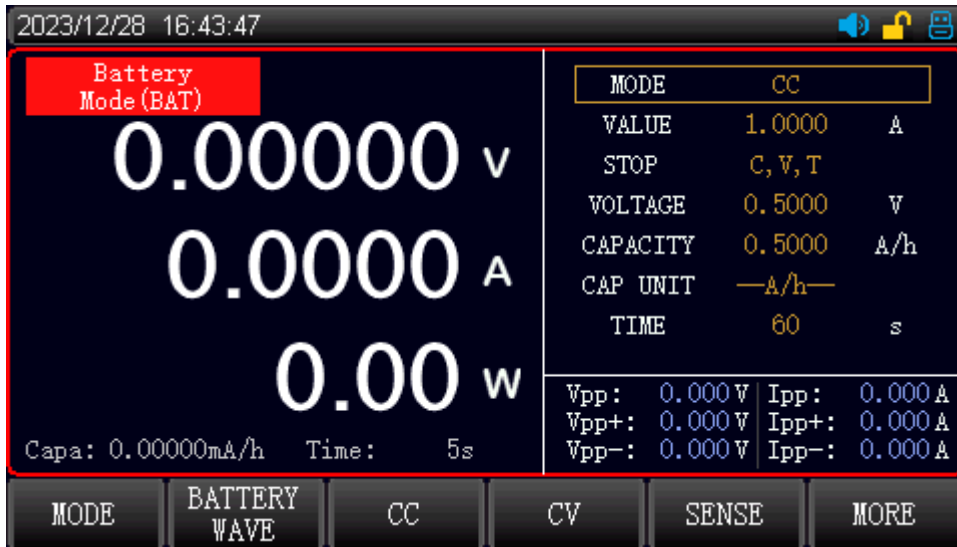

Figure 7-2-10 Battery Test Interface

Parameter Setting of Battery Test

Parameter	Description
Mode	Discharge mode: CC/CR/CP
Value (Load value)	Set the load value
Stop (Stop condition)	Set the stop condition for this test
Voltage (Cut-off voltage)	Set the lower limit of voltage (cut-off voltage) for stop discharge
Capacity (Cut-off capacity)	Set the accumulated capacity for stop discharge
Time (Cut-off time)	Set the stop time for this test

In the battery test, select a discharge mode according to the needs and set the load and cut-off voltage. The electronic load will automatically stop load when the battery has discharged to the cut-off voltage.

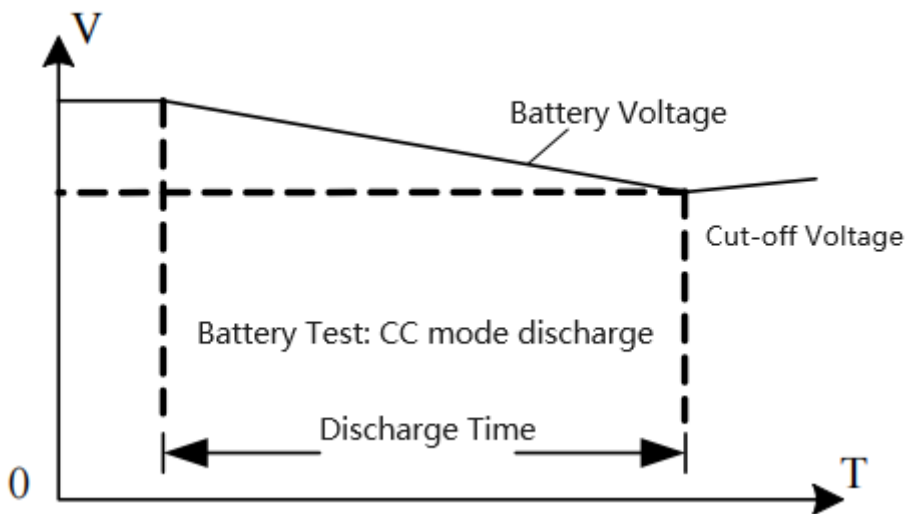

Figure 7-2-11 Battery Test Interface

Description of battery test mode

During the battery test, the battery voltage, discharge current and discharged capacity can be monitored at any time.



Figure 7-2-12 Charge and Discharge Curve

Note: The battery test curve can only be displayed after the test is finished!

Operation Steps

1. Select the **[Mode]** key on the initial interface, and press the **[MORE]** key to select the **[BATTERY]** key to enter the **<Battery Mode (BAT)>** page.
2. Use the rotary knob to move the cursor to the field to be set, and press the **rotary knob** to change the field area from black to brown, at this point, the field area can be set. Use the keyboard or press the rotary knob to enter the set value and then press the **rotary knob** to confirm. The field area will change from brown to black.
3. The operation step of other parameters are the same as above.
4. The electronic load starts to work when the **ON/OFF** key is pressed, and the indicator will be illuminated. Press the **ON/OFF** key again, the electronic load will stop working, and the indicator will be extinguished.

7.2.7 Automatic List Test

The automatic list test can switch between different modes by setting the parameter. For power product and charger device, through multi-parameter mixed test, the overall performance characteristic of the measured under the actual application field can be fully understood.



Figure 7-2-13 Automatic List Test Setting Interface

Parameter setting of automatic list test

List Mode	Parameter	Description
List name	24 characters	Set the English name of this list test file for later use
Mode	Continuous/Pulse /CONT+EX) /Pulse+EX	Set the switch mode and stop mode for each step
Step	1~200	Set the step for this group list test
Repeat	1~10000000/LOOP(0)	Set the repeat time for the current list file
V on (Load voltage)	0.01- Maximum load voltage	The test will automatically start when it reaches the load voltage

List Filename

The internal Flash of the electronic load can save up to 200 groups of list files. When setting the list parameter, please set the list name at first to distinguish different files. EX in the operation mode indicates that the load will automatically stop load if an exception occurs or the check range is exceeded during the operation.

Press the rotary knob to enter name editing and open the virtual keyboard, use the rotary knob to quickly select the enter character, and press the rotary knob to enter the currently selected cursor character, and then press the menu key to save.

The delete key is used to quickly clear the name. The backspace key is used to clear a character. The return key is used to exit the current edit.

Editing List Parameter

The step setting is to quickly preset the test step. Press the list key to enter the list parameter page, use the rotary knob to edit the list parameter. Press the rotary knob and then press the numerical keyboard to enter the set parameter, after the edit is completed, press the softkey "More>>" and save key to save the AutoLIST file.

Operation Mode

Four modes: Continuous/pulse/continuous+EX/pulse+EX

Continuous mode: the load electronic will perform one step and then continue to the next step until the end of the run.

Pulse mode: the load electronics will pause after executing a step. It waits for a trigger signal to execute the next step.

EX mode: the load electronic will automatically stop load if an exception occurs or the limit is exceeded during the operation.

Press [LIST PARAM] key to enter the parameter setting of list parameter.

Parameter setting of list parameter

Item	Parameter	Description
No.	1-16	Set the step for this group list test
Mode	CC/CV/CR/CP/Open/Short	Select the current step
Value (Constant value)	Set the constant value for the mode	Set the constant value for the mode, the default constant value of Open/Short is 1
Time	100~9999999 mS	Set the load time for each step, which can be selected the from the range of 100~9999999 mS
Exami (Check)	OFF/current/voltage/power/IPP/VPP	Select the check item
Lower limit	The lower limit of check item	Set the lower limit of check item
Upper limit	The upper limit of check item	Set the upper limit of check item

When the test is complete, the user can press the soft menu key to check the test result. If the test result is within the user-defined upper and lower limit, then the test result will display Pass. If the test result does not meet the upper and lower limit, then the test result will display Fail. In addition, the test result of each item can be checked.

When using the check function of the automatic list mode, the range of the check item cannot be checked in single constant mode. For example, in CC mode, only the voltage and power value can be checked, the upper and lower limit of the current cannot be checked.

After the parameter is set, press the save key to save the list parameter to the current file.

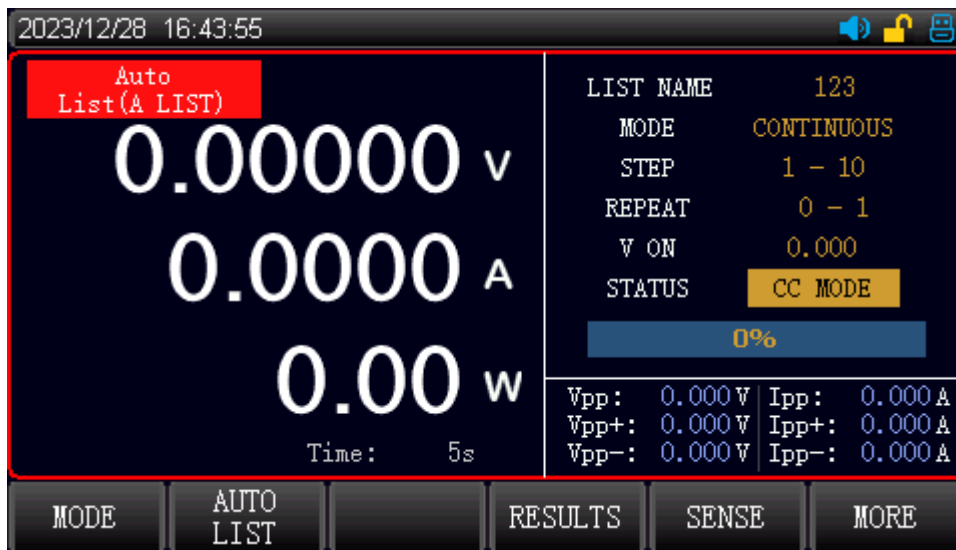

Figure 7-2-14 Automatic List Test Interface

Operation Steps

1. Select the [Mode] key on the initial interface, or press the [MORE] key to select the [AUTO LIST] key to enter the <Auto List (A LIST)> page.
2. Use the rotary knob to move the cursor to the field to be set, and press the rotary knob to change the field area from black to brown, at this point, the field area can be set. Use the keyboard or press the rotary knob to enter the set value and then press the rotary knob to confirm. The field area will change from brown to black.
3. The operation step of other parameters are the same as above.
4. The electronic load starts to work when the ON/OFF key is pressed, and the indicator will be illuminated. Press the ON/OFF key again, the electronic load will stop working, and the indicator will be extinguished.



Note: The input data cannot exceed the upper and lower limit of the current parameter. If the input data exceeds the parameter limit, the data cannot be saved and the cursor will stay in the box. At this point, the input data should be cleared or re-enter the proper range. When the number in the list needs to be changed, click the delete key to clear the data in the list. Each time the parameter setting is completed, press the save key to save the parameter setting for later use.

7.2.8 Short Circuit Test

The electronic load can simulate a short-circuited circuit in the input terminal, it is used to detect whether the protection function of the DUT is working when the output terminal of the DUT is short-circuited.

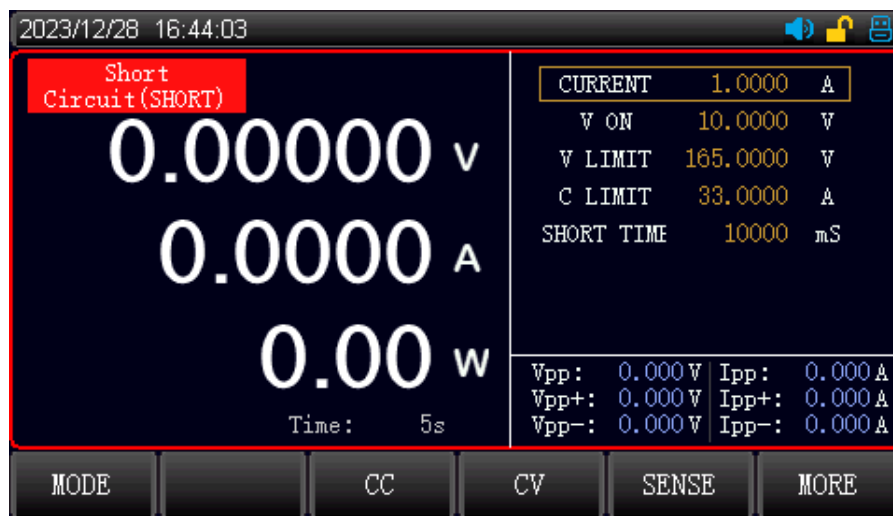

Figure 7-2-15 Short Circuit Test Interface

Parameter Setting of Short Circuit

Parameter	Description
Current (Load current)	The load current that is not in the short circuit state
V ON (Load voltage)	Set the starting voltage for enabling load
V Limit (OVP)	Set the protection value for OVP
C Limit (OCP)	Set the protection value for OCP
Short Time	Set the short test time

In the short-circuit test, when the short-circuit test is enabled by pressing the TRIG key and the set short-circuit time is reached, the electronic load returns to its original operating state.

The actual current drawn by the electronic load in short-circuit mode, it depends on the current operating mode and current range of the electronic load. During the short-circuit test, the electronic load is loaded

with the full range, and if one of the current/power reaches the upper limit first, the load is loaded with the full range of this upper limit.



Note: The short circuit mode can only be valid in CC, CV, CR and CP mode.

When the nominal power of the power supply is greater than the maximum power 1.5 times of the electronic load, the function should be tested with an appropriate voltage setting before use.

Appropriate voltage < maximum nominal power of the electronic load / maximum nominal current of power supply

Operation Steps

1. Select the **[Mode]** key on the initial interface, and press the **[MORE]** key to select the **[SHORT]** to enter the **<Short Circuit (SHORT)>** page.
2. Use the rotary knob to move the cursor to the field to be set, and press the **rotary knob** to change the field area from black to brown, at this point, the field area can be set. Use the keyboard or press the rotary knob to enter the set value and then press the **rotary knob** to confirm. The field area will change from brown to black.
3. The operation step of other parameters are the same as above.
4. The electronic load starts to work when the **ON/OFF** key is pressed, and the indicator will be illuminated. Press the **ON/OFF** key again, the electronic load will stop working, and the indicator will be extinguished.
5. Press the function key **TRIG** at the bottom of screen to enter the short circuit test mode, the state bar will display "Short" character when this mode is enabled.
6. Note: the step 4 and step 5 can be exchanged, if the step 4 is executed before the step 5, press the **ON/OFF** key to enable the electronic load, the electronic load will load with the set current and then enter the short-circuit state. If the step 5 is executed before the step 4, press the **ON/OFF** key to enter the short-circuit state directly.

7.2.9 Load Effect Test

The load effect test can be performed under three different load conditions (10%, 50%, 100%), each for a preset time (5 s), and then record the voltage values under different loads, and finally calculate the load regulation rate, ΔV and R_s .

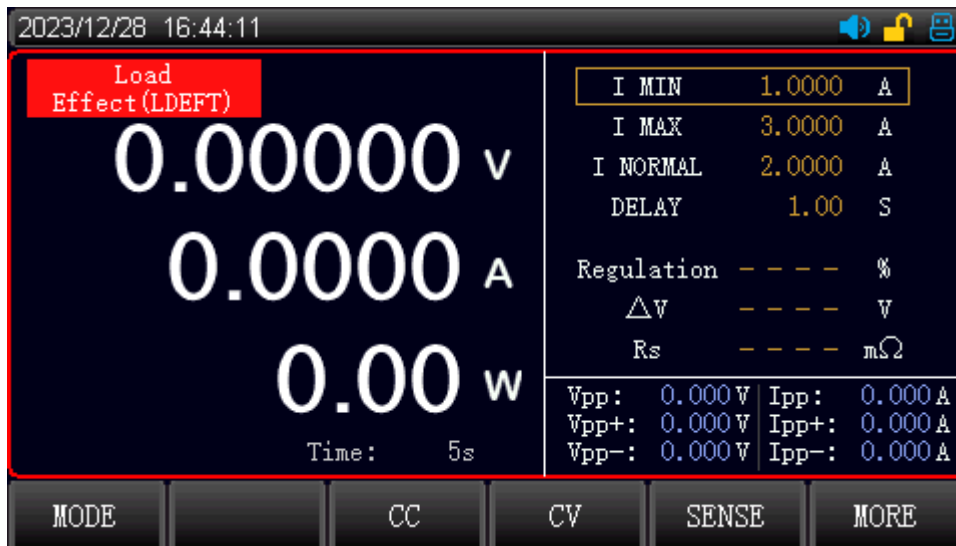

Figure 7-2-16 Load Effect Test Interface

Parameter Setting of Load Effect

Parameter	Description
I Min	Set load current that stimulates low current working load
I Max	Set load current that stimulates high current working load
I Normal	Set load current stimulates normal current working load
Delay	Set the transfer residence time e of the load under each simulated load

During the load effect test, the electronic load calculates ΔV and Regulation (load regulation ratio) according to the three different loads.

$$V_{max} = V_{dc} @ I_{min}$$

$$V_{min} = V_{dc} @ I_{max}$$

$$\Delta V = V_{max} - V_{min}$$

$$R_s = \Delta V / (V_{max} - V_{min})$$

$$\text{Regulation} = \Delta V / V_{normal}$$

Before the load effect test, the rated voltage and rated current should be entered firstly, and then press the ON/OFF key to enter the test, the electronic load will be loaded with three different load in turn and detect the value of ΔV , regulation and R_s . During the test, the ON/OFF key can be used to control the load switch.

Operation Steps

1. Select the [Mode] key on the initial interface, and press the [MORE] key to select the [LOAD EFFECT] to enter the <Load Effect (LDEFT)> page.
2. Use the rotary knob to move the cursor to the field to be set, and press the rotary knob to change the field area from black to brown, at this point, the field area can be set. Use the keyboard or press the rotary knob to enter the set value and then press the rotary knob to confirm. The field area will change from brown to black.
3. The operation step of other parameters are the same as above.
4. The electronic load starts to work when the ON/OFF key is pressed, and the indicator will be illuminated. Press the ON/OFF key again, the electronic load will stop working, and the indicator will be extinguished.

7.2.10 Dual Mode (Dual)

In order to meet more test requirements, the electronic load provides three combination modes, CR+CC, CV+CR, CV+CC. The user can choose the appropriate mode according to the actual situation. CR+CC can be used for power-on test of power supply. CV+CR can be used for Von point setting application. CV+CC can be applied to the battery discharge test.

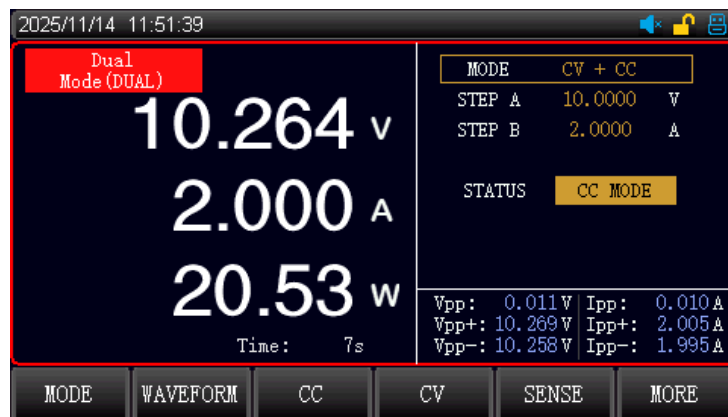

Figure 7-2-17 Combination Test Interface

Parameter Setting of Battery Test

Parameter	Description
Dual Mode	CR+CC/CV+CR/CV+CC
Step A (Starting value)	Set the load value of starting mode under the combination mode
Step B (Switching value)	Set the load value of switching mode under the combination mode

Before using the combination test, select the combination mode and set the constant value for the two mode. When the electronic load starts to load, it will be loaded with the constant value of the first mode, and

when the external input changes the parameter to the set switching value, the electronic load switches to the second load mode.

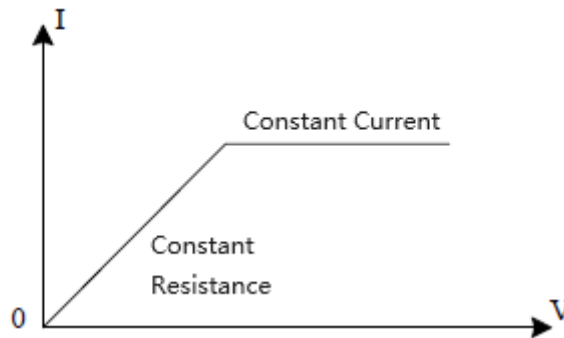

Figure 7-2-18 Combination Test Mode

Description of combination test

When using the combination test, it is necessary to set appropriate starting and switching parameters to ensure that the effective switching can be performed during the test process.

Operation Steps

1. Select the **[Mode]** key on the initial interface, and press the **[MORE]** key to select the **[DUAL]** to enter the **<Dual Mode (DUAL)>** page.
2. Use the rotary knob to move the cursor to the field to be set, and press the **rotary knob** to change the field area from black to brown, at this point, the field area can be set. Use the keyboard or press the rotary knob to enter the set value and then press the **rotary knob** to confirm. The field area will change from brown to black.
3. The operation step of other parameters are the same as above.
4. The electronic load starts to work when the **ON/OFF** key is pressed, and the indicator will be illuminated. Press the **ON/OFF** key again, the electronic load will stop working, and the indicator will be extinguished.

7.2.11 List Test

The list test is used to simulate the actual load condition or to edit the complicated load waveform. The electronic load is loaded according to the sequence in the file and loaded in sequence.

The electronic load supports up to 21 files. Each file supports up to 200 steps. The current change rate can be set for each step.



Figure 7-2-19 List Test Interface

Parameter setting of list test

List Mode	Parameter	Description
Enable file	0~20	Set the name of test file for later use
Step	0~200	Set the test step for this group list test
Repeat	1~10000000/LOOP	Set the repeat time for the current list file. (In continuous mode, this setting is invalid.)
Mode	Continuous/count/step	Set the switch and stop mode for each step

Enable File

The internal Flash of the electronic load can save up to 21 groups of list files. When setting the list parameter, please set the list name at first to distinguish different files.

Press the rotary knob to enter name editing and open the virtual keyboard, use the rotary knob to quickly select the enter character, and press the rotary knob to enter the currently entered parameter, and then press the menu key to save.

The backspace key is used to clear a character. The return key is used to exit the current edit.

Editing List Parameter

The step setting is to quickly preset the test step. Press the list key to enter the list parameter page, use the rotary knob to edit the list parameter (the blue checkbox is the quick selection box of LIST Step, and the green checkbox is the edit box of LIST Subdivision Entry). Press the rotary knob and then press the numerical keyboard to enter the set parameter, after the edit is completed, press the softkey "More>>" and save key to save the LIST file.

Operation Mode

Operation mode: continuous/count/step

Continuous: the electronic load is continuously loaded in sequence.

Count (Step by step): Each time a trigger signal is received, the electronic load will load in sequence and repeat the period of 1~10000000. The electronic load will stop load when the test is finished.

Step: Each time a trigger signal is received, the electronic load will set the load according to the next step in the file.

Parameter setting of list test mode

Item	Parameter	Description
No.	1~200	Set the test step for this group list test
Current	0~30A	Load current
Slew Rate	0.0006A/us~3A/us	The current change rate
Dwell (Single step time)	0.00001s~100000s	Set the load time for each step, which can be selected from the range of 0.00001s~100000s

After the parameter is set, press the save key to save the list parameter to the current file.

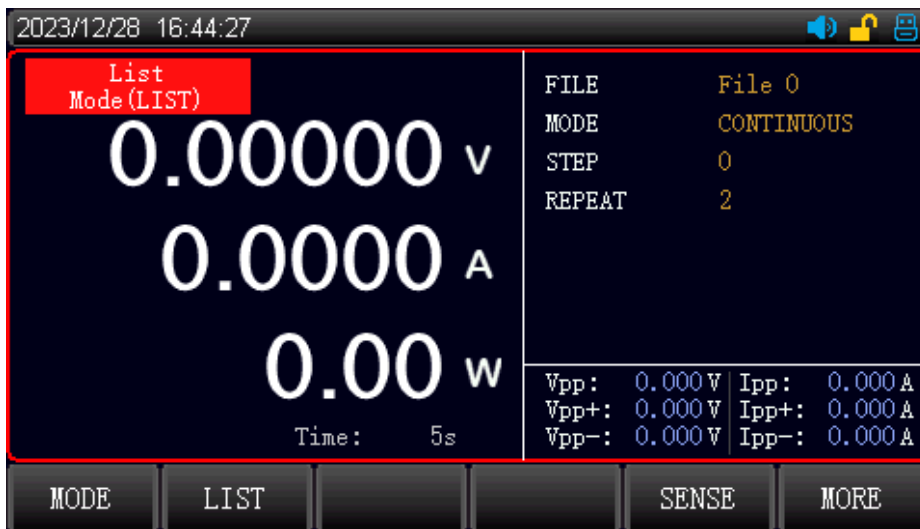

Figure 7-2-20 List Test Mode Interface

Operation Steps

1. Select the [Mode] key on the initial interface, and press the [MORE] key to select the [LIST] to enter the <List Mode (LIST)> page.
2. Use the rotary knob to move the cursor to the field to be set, and press the rotary knob to change the field area from black to brown, at this point, the field area can be set. Use the keyboard or press the rotary knob to enter the set value and then press the rotary knob to confirm. The field area will change from brown to black.

3. The operation step of other parameters are the same as above.
4. The electronic load starts to work when the **ON/OFF** key is pressed, and the indicator will be illuminated. Press the ON/OFF key again, the electronic load will stop working, and the indicator will be extinguished.



Note: The input data cannot exceed the upper and lower limit of the current parameter. If the input data exceeds the parameter limit, the data cannot be saved and the cursor will stay in the box. At this point, the input data should be cleared or re-enter the proper range. When the number in the list needs to be changed, click the delete key to clear the data in the list. Each time the parameter setting is completed, press the save key to save the parameter setting for later use.

7.3 Parameter Input and Load Measurement

The electronic load has two parameter input methods. The entered parameter can be changed by using the arrow key or the rotary knob. The electronic load can be controlled by pressing the ON/OFF key on the front panel. The detailed is described in the following sections.

7.3.1 Keyboard Input

Entering the parameter setting interface, select the parameter to be set and use the numerical keyboard to enter the parameter directly, and then press the rotary knob after the setting is completed.

If the set parameter is within the valid range, then the parameter will be available and displayed on the screen. If the user set parameter exceeds the upper/lower limit, the set number will not appear and the cursor will jump to the first number, at this point, re-enter a number that within the valid range and then press the rotary knob to complete the setting.

7.3.2 Rotary Knob Input

Before entering the parameter, the cursor has a default value, it can be adjusted by using the rotary knob and moving the arrow key to move the cursor until the number is set, and then press the rotary knob to complete the setting.

Note: When the parameter reaches the upper/lower limit set by the rotary knob, the number cannot be changed.

7.3.3 Ripple Measurement

UTL1000S series supports the measurement and simultaneous display of voltage ripple (Vpp) and current ripple (Ipp). The measurement method is different from that of a traditional oscilloscope. The ripple measurement has good flatness and accuracy in a given measurement range and bandwidth. Meanwhile, the ripple contains two different frequency bands of ripple, industrial frequency ripple and switching ripple. The ripple test result of the electronic load is the effect of the superposition of two ripples.

7.3.4 Input Control

When the electronic load is turned on but the load is not working, press the ON/OFF key on the front panel to control the input switch. If the ON/OFF indicator is lighted, which indicates the input is enabled and the real-time voltage, current and power in the current loop will be displayed on the screen. If the ON/OFF indicator is off, which indicates the input is disabled and the voltage at the both ends will be displayed on the screen.

7.4 Trigger Mode



When dynamic mode, list test, and time test are used, the external trigger function of electronic load may be used. You can enable the external trigger input function by turning on the external trigger switch. Trigger level High level trigger and low level trigger can be selected.

Operation steps:

1. Press [Menu] key to enter the system Settings, the soft key at the bottom of the screen [Dynamic Settings] to select dynamic Settings. External triggering is disabled by default. External triggering is enabled when external triggering is enabled.
2. When the external trigger switch is turned on, the trigger signal is connected through the trigger terminal of the electronic load rear panel. Each action of the load is controlled, and the effective level of the control signal can be set by modifying the trigger level.
3. The Trig key on the panel can also trigger control during debugging.
4. When applying AUTOLIST test function with PLC, the signal port interface and pin distribution are shown in section 9.4. In this mode, the control signal port is defined as follows:

RX - Test start signal

TX - Tests NG output signal

DFI - Test completion signal

5. The test timing diagram is shown as follows:

When using the dynamic mode, list test and time test, it may use the external trigger function, the user can enable the external trigger input function by turning on the external trigger switch.

The trigger level can select high level trigger or low level trigger.

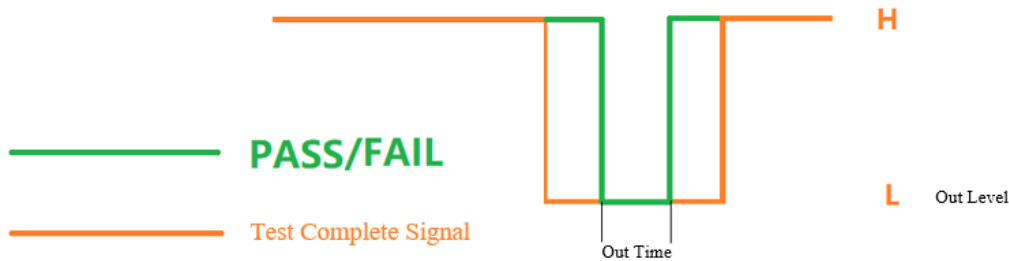

7.5 Sense Function

When the electronic load consumes a large current, it will generate a large voltage drop between the electronic load and the DUT's connecting wire. To ensure an accurate measurement, the electronic load provides a Sense terminal in the rear panel, the terminal can measure the accurate voltage of the DUT's output terminal.

Operation Steps

1. On each test page, press the function key [SENSE] at the bottom of the screen, an icon of [Sense] will appear on the top of the screen, indicating that the remote compensation function is enabled. At this point, the voltage detected by the sense terminal as the actual voltage.
2. Press the function key [SENSE] again to turn off the remote compensation function. At this point, the voltage of the main terminal connected to the front panel as the actual voltage.



Note: The DUT must be correctly connected to the positive and negative terminals.

During the test, Sense cannot be switched.

7.6 Screenshot

When USB connects to the front panel, the electronic load will automatically recognize a USB device and an icon



will display in the right corner of the screen, indicating that USB is connected.

The screenshot function can be used by long pressing the rotary knob, and then the current screenshot will save to USB. During the save process, a loading bar will display at the bottom of the screen, it will automatically disappear when the storage is complete, indicating that the current screenshot has been successfully saved to USB.

Because the screenshot takes up a lot of space, it can only be saved to USB. The screenshot in USB can be checked by the computer.

The screenshot path is USB:\UTL1000S\SCREENSHOT

7.7 Save/Load List Configuration

A new file folder "UTL1000S" will appear in the root directory when the electronic load detects a USB connection. This directory is used to save the screenshot and the list configuration file. File manager can be used by selecting [MORE] on the list parameter interface, and pressing the [FILE] key at the bottom of the screen, and then performing the operation of delete file, save file to USB or load file, etc.

The screenshot name consists of 4 numbers in sequence and is in BMP format. The list file name is the current file name and in .csv format. These files can be opened and edited by using EXCEL software and then load to the device.

UTL1000S series can save frequently-used test file to USB or internal Flash, Flash can save up to 200 groups of test files.



Note: USB format must be FAT32 and the allocation size cannot greater than 4096 bytes. The maximum capacity is 32G.

Before using USB, please formatting USB in advance, otherwise it may fail to save the file. It is recommended to use a branded USB.

7.8 Real-time Waveform

UTL1000S series has real-time waveform display function, press the function key [WAVE] at the bottom of the screen to check the voltage and current waveform as shown in Figure 7-7-1. (Due to hardware limitations, 50Hz dynamic mode can not display conventional dynamic waveform.)

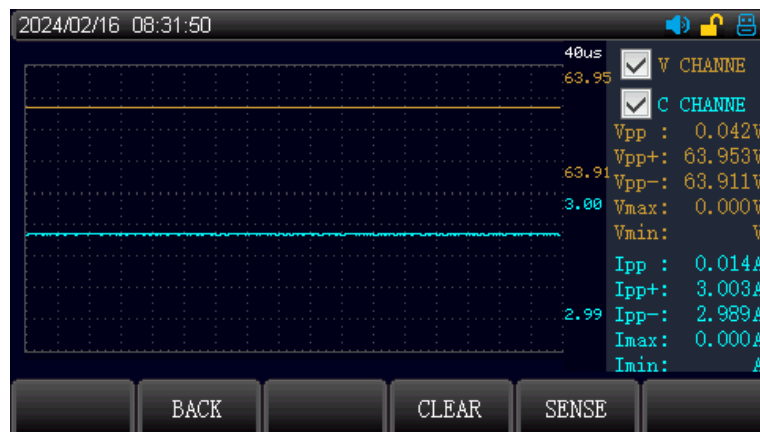

Figure 7-7-1 Current and Voltage Waveform under CC Mode

Ripple value: the ripple value of voltage and current is displayed on the right side, orange is the voltage wave data, the blue is current wave data.

Period: 40us is period for each grid

Note: voltage and current waveform is self-adopting display

8. System Setting

In non-operation state, press the [Menu] key on the front panel to enter the system configuration page. The system configuration page is divide into <System Configuration>, <Parameter Setting>, <Dynamic Setting>, <CV Setting> and <Device Information>. Press the function key at the bottom of the screen to select the corresponding setting page.

8.1 <System Configuration> Page

Press the [System] key to enter the <SYSTEM CONFIG> page as shown in Figure 8-1.

Language, time and communication and other setting can be set in this page, refer to Table 8-1 for more details.



Figure 8-1 <System Configuration> Page

Table 8-1 <System Configuration>

System parameter	Setting	Description
Language	Simplified Chinese/English	Set the system language
Date	Year/month/day	Set the system date
Time	Hour/minute/second/	Set the system time
Key Beep	OFF/ON	Set whether the key sound is turned on
Warning Beep	OFF/ON	Set whether the alarm sound is turned on
Real Recording (Power-off record)	OFF/ON	Set whether the power-off record is recorded
Knob Active (Effective immediately)	OFF/ON	Set whether the effective immediately function is turned on
Measure Rate	High/fast/medium/slow	The test speed has four ranges
Com Bus	RS232/RS485	Set the communication port (RS485 can connect converter)
Com Mode	SCPI/MODBUS	Select the communication protocol

		(MODBUS keeps extension)
Brightness	5/20/40/50/60/80/100%	Set the brightness of the screen
Address	1~255	Multi-machine communication for 485 bus
BPS (Baud rate)	4800/9600/19200/ 38400/57600/115200	Set the baud rate for the communication port
Factory set	Reset	The instrument will clear the current settings and restore to the factory settings

8.2 <Parameter Setting> Page

Press the [Menu] key to enter the system configuration page, select the [PARAMETER SETTING] at the bottom of the screen to enter the parameter setting page as shown in Figure 8-2. The parameter setting is used to set the operating parameter and protection parameter.



Figure 8-2 Parameter Setting Page

Parameter	Range	Description
V range	High/low	0~150 V/0~15 V
I range	High/low	0~30 A/0~3 A
Power type	CC Source/CV Source/Auto detect	Set the measured power type
V Limit (OVP)	0~150 V*110 %	Set the protection value for OVP
C Limit (OCP)	0~30 A*110 %	Set the protection value for OCP
OC T(Overcurrent time)	0-9999.99 mS	Set the overrun hold time for OCP
P Limit	0~400 W*110 %	Set the protection value for OPP
Power T	0-9999.99 mS	Set the overrun hold time for OPP
V ON(Load voltage)	0~150 V	Set the load voltage for the start of each run
V OFF (un-load voltage)	0~150 V	Set the low voltage for automatic end of load
I-rise	0.0006~3 A/uS	Set the current rising slope under loading
I-fall	0.0006~3 A/uS	Set the current falling slope under loading
Run T	0 (OFF)-9999.99S	The pull load is held until the discharge time is

		reached and then automatically unloaded.
V-auto (Auto-start voltage)	0 (OFF)-150 V	The auto-start is enabled when detecting the self-start voltage is greater than the set value.
Under V Limit (Runt-voltage protection)	0 (OFF)-150 V	When the power is pull loading, it will alarm if the voltage is lower than the set voltage.
Reverse T (Reversed connection time)	0-9999.99 mS	Protection hold time for power reversed connection

8.3 <Dynamic Setting> Page

Press the [Menu] key to enter the <SYSTEM CONFIG> page, and then select the function key [DYNAMIC SETTING] at bottom of the screen to enter the [DYNAMIC SETTING] page. The setting is used to set the relevant setting of dynamic. The external trigger and trigger condition are suitable for each trigger setting.



Figure 8-3 Dynamic Setting Page

Parameter	Range	Description
Ia	0~30A	Current of A point
Ta	0.01~1000000 mS	Current hold time of A point
Ib	0~30A	Current of B point
Tb	0.01~1000000 mS	Current hold time of B point
R-slope	0.0006~3A/uS	Set the current rising rate for the dynamic test
F-slope	0.0006~3A/uS	Set the current falling rate for the dynamic test
Mode	Continuous/pulse/toggle	Set the operation mode for the dynamic test
External trig	OFF/ON	Set the input switch for the external trigger signal
Trig level	Low/High	Set the input level signal for the external trigger signal
Out Level	Low/High	Level output of the PASS/FAIL signal used to complete the automatic list function test
Out Time	HOLD/xx ms	Level output hold time of PASS/FAIL signal

		used for automatic list function test completion. (xx ms/HOLD until next test triggers signal)
--	--	--

8.4 <CV Setting> Page

Press the [Menu] key to enter the <SYSTEM CONFIG> page, and then select the function key [CV SETTING] at bottom of the screen to enter the [CV SETTING] page. CV setting includes voltage rate and loop circuit rate.



Figure 5-4 CV Setting Page

Parameter	Range	Description
Voltage rate	0.001~3 V/ mS	Set the voltage rising and falling rate
Loop circuit rate	Default /1~8 range	Set the loop circuit response rate under the CV mode, select an appropriate speed range for more power test

8.5 Device Information

This page displays the device information of model, serial number, software version and hardware version.



9. Communications

9.1 RS232

UTL1000S series is equipped with RS232, so the user can choose the communication wire for remote control.

There is a DB9 female connector at the end of the electronic load which can be connected to the COM port of the computer using a standard RS-232 cable.

When purchasing a USB communication cable, please note that USB to serial RS232 cable is preferred.

Caution: In practice, the electronic load uses only three pins of 2.3.5 to communicate with the device. It is recommended to switch off the instrument when connecting to the connector to avoid electric shock.

The standard interface is RS232, an adapter is needed to use RS485

DB9 Pin Definition:

Pin No.	Symbol	Description
1	E5V	External Power Supply
2	TXD	Transmit Data
3	RXD	Receive Data
4	----	----
5	GND	Signal Ground
6	----	----
7	----	----
8	RS485_A	RS485_A
9	RS485_B	RS485_B

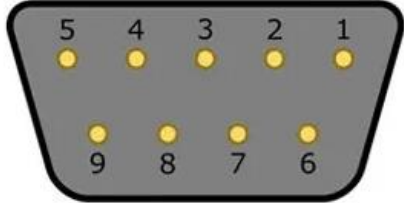

9.2 Communication Setting

Communication setting is used to set the communication parameter between the electronic load and the upper computer. The electronic load communicates with the upper computer through RS232, and users can purchase the required connection cable to realize the remote control with the electronic load.

Before connecting to the upper computer, please make sure you have purchased the specified connection cable and set the correct communication parameters in the system settings.

Setting steps

1. Press the [System] key on the panel to enter the <SYSTEM CONFIG> page.
2. Select [COMS BUS] and [BPS] on the <SYSTEM CONFIG> page, set the parameter is same as that of the upper computer.

9.3 Sense Terminal

When the electronic load consumes a large current, it will generate a large voltage drop between the electronic load and the DUT's connecting wire. To ensure an accurate measurement, the electronic load provides a Sense terminal in the rear panel, the terminal can measure the accurate voltage of the DUT's output terminal.

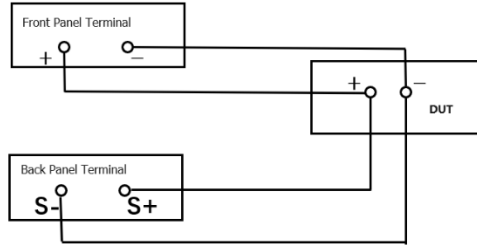

Figure 9-1 Wiring of Sense Terminal

S+ and S- are the remote input terminal. To avoid voltage drops caused by long load input lines, the remote test allows the input terminal source to be measured directly to improve measurement accuracy.

9.4 Handler Interface

Connection terminal

Terminal	Description
RX	Keep/remote control pull load
TX	External trigger signal output
DFI	Device failure output
RI	Forbid remote input signal
TRI	Trigger signal input (TRIG)
GND	Ground (GND)

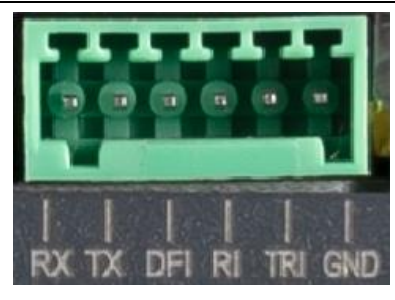

A trigger is activated when the TRIG port is pulled low.

9.5 Factory Setting

After the reset is completed, the instrument setting will restore to the preset parameter.

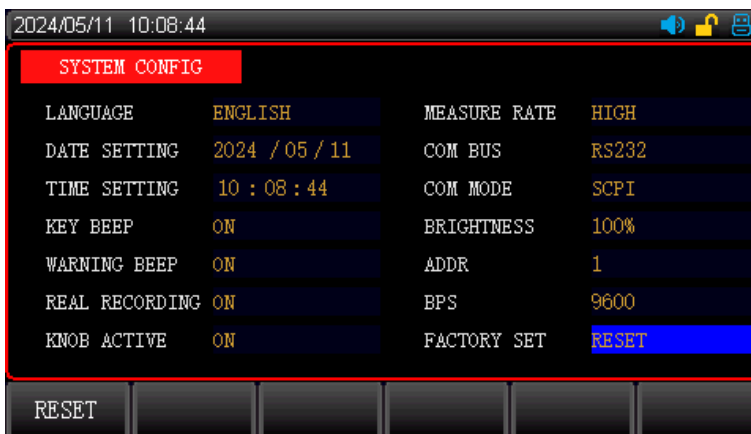

Figure 9-2 Factory Setting Page

Operation steps of factory setting

1. Press the [System] key on the panel to enter the <SYSTEM CONFIG> page.
2. Select [FACTORY SET] on the <SYSTEM CONFIG> page, and then press the confirm key to restore the instrument setting to the preset parameter.
3. After the reset is completed, do not operate. The instrument will automatically reboot after 2 seconds.

10. Appendix

10.1 Appendix A Maintenance and Cleaning

(1) General maintenance

Keep the instrument away from the direct sunlight.

Caution

Keep sprays, liquids and solvents away from the instrument or probe to avoid damaging the instrument or probe.

(2) Cleaning

Check the instrument frequently according to the operating condition. Follow these steps to clean the external surface of the instrument:

- a. Please use a soft cloth to wipe the dust outside the instrument.
- b. When cleaning the LCD screen, please pay attention and protect the transparent LCD screen.
- c. When cleaning the dust screen, use a screwdriver to remove the screws of the dust cover and then remove the dust screen. After cleaning, install the dust screen in sequence.
- d. Please disconnect the power supply, then wipe the instrument with a damp but not dripping soft cloth. Do not use any abrasive chemical cleaning agent on the instrument or probes.

Warning

Please confirm that the instrument is completely dry before use, to avoid electrical shorts or even personal injury caused by moisture.

11. Limited Warranty and Liability

Uni-T guarantees that the Instrument product is free from any defect in material and workmanship within three years from the purchase date. This warranty does not apply to damages caused by accident, negligence, misuse, modification, contamination or improper handling. If you need warranty service within the warranty period, please contact your seller directly. Uni-T will not be responsible for any special, indirect, incidental or subsequent damage or loss caused by using this device. For the probes and accessories, the warranty period is one year. Visit instrument.uni-trend.com for full warranty information.



Learn more at: www.uni-trend.com



Register your product to confirm your ownership. You will also get product notifications, update alerts, exclusive offers and all the latest information you need to know.

UNI-T is the licensed trademark of UNI-TREND TECHNOLOGY (CHINA) CO., Ltd.

UNI-T products are protected under patent laws in China and internationally, covering both granted and pending patents. Licensed software products are the properties of UNI-Trend and its subsidiaries or suppliers, all rights reserved. This manual contains information that replaces all earlier published versions. The product information in this document subject to update without notice. For more information on UNI-T Test & Measure Instrument products, applications, or service, please contact UNI-T instrument for support, the support center is available on www.uni-trend.com ->instruments.uni-trend.com
<https://instruments.uni-trend.com/ContactForm/>

Headquarter

UNI-TREND TECHNOLOGY (CHINA) CO., Ltd.
 Address: No.6, Industrial North 1st Road, Songshan Lake Park, Dongguan City, Guangdong Province, China
 Tel: (86-769) 8572 3888

Europe

UNI-TREND TECHNOLOGY EU GmbH
 Address: Steinerne Furt 62, 86167 Augsburg, Germany
 Tel: +49 (0) 821 8879980

North America

UNI-TREND TECHNOLOGY US INC.
 Address: 2692 Gravel Drive, Building 5, Fort Worth, Texas 76118
 Tel: +1-888-668-8648