

# BME680

Low power gas, pressure, temperature & humidity sensor



## BME680 – Datasheet

Document revision	1.3
Document release date	July 2019
Document number	BST-BME680-DS001-03
Technical reference code(s)	0 273 141 229; 0 273 141 312
Notes	Data and descriptions in this document are subject to change without notice. Product photos and pictures are for illustration purposes only and may differ from the real product appearance.



## BME680

### Low power gas, pressure, temperature & humidity sensor

The BME680 is a digital 4-in-1 sensor with gas, humidity, pressure and temperature measurement based on proven sensing principles. The sensor module is housed in an extremely compact metal-lid LGA package with a footprint of only  $3.0 \times 3.0 \text{ mm}^2$  with a maximum height of 1.00 mm ( $0.93 \pm 0.07 \text{ mm}$ ). Its small dimensions and its low power consumption enable the integration in battery-powered or frequency-coupled devices, such as handsets or wearables.

#### Typical applications

- Indoor air quality
- Home automation and control
- Internet of things
- Weather forecast
- GPS enhancement (e.g. time-to-first-fix improvement, dead reckoning, slope detection)
- Indoor navigation (change of floor detection, elevator detection)
- Outdoor navigation, leisure and sports applications
- Vertical velocity indication (rise/sink speed)

#### Target Devices

- Handsets such as mobile phones, tablet PCs, GPS devices
- Wearables
- Home weather stations
- Smart watches
- Home appliances
- Navigation systems
- Gaming, e.g. flying toys
- IOT devices

## Key features

- Package 3.0 mm x 3.0 mm x 0.93 mm metal lid LGA
- Digital interface I<sup>2</sup>C (up to 3.4 MHz) and SPI (3 and 4 wire, up to 10 MHz)
- Supply voltage V<sub>DD</sub> main supply voltage range: 1.71 V to 3.6 V  
V<sub>DDIO</sub> interface voltage range: 1.2 V to 3.6 V
- Current consumption 2.1 µA at 1 Hz humidity and temperature  
3.1 µA at 1 Hz pressure and temperature  
3.7 µA at 1 Hz humidity, pressure and temperature  
0.09–12 mA for p/h/T/gas depending on operation mode  
0.15 µA in sleep mode
- Operating range -40–+85 °C, 0–100% r.H., 300–1100 hPa
- Individual humidity, pressure and gas sensors can be independently enabled/disabled
- The product is RoHS compliant, halogen-free, MSL1

## Key parameters for gas sensor

- Response time ( $\tau_{33-63\%}$ ) < 1 s (for new sensors)
- Power consumption < 0.1 mA in ultra-low power mode
- Output data processing direct index for air quality (IAQ) output

## Key parameters for humidity sensor

- Response time ( $\tau_{0-63\%}$ ) ~8 s
- Accuracy tolerance ±3% r.H.
- Hysteresis ±1.5% r.H.

## Key parameters for pressure sensor

- RMS Noise 0.12 Pa, equiv. to 1.7 cm
- Offset temperature coefficient ±1.3 Pa/K, equiv. to ±10.9 cm at 1 °C temperature change

# Table of contents

<b>1. Specification</b>	<b>7</b>
1.1 General Electrical Specification .....	7
1.2 Gas sensor specification .....	8
1.3 Humidity sensor specification.....	10
1.4 Pressure sensor specification .....	11
1.5 Temperature sensor specification .....	12
<b>2. Absolute maximum ratings</b>	<b>13</b>
<b>3. Sensor usage</b>	<b>14</b>
3.1 Sensor modes .....	14
3.2 Sensor configuration .....	15
3.2.1 Quick start .....	15
3.2.2 Sensor configuration flow.....	16
3.3 Measurement flow.....	17
3.3.1 Temperature measurement.....	17
3.3.2 Pressure measurement.....	18
3.3.3 Humidity measurement .....	19
3.3.4 IIR filter .....	21
3.3.5 Gas sensor heating and measurement.....	21
3.4 Data readout.....	22
3.4.1 Gas resistance readout.....	22
<b>4. Software and use cases</b>	<b>24</b>
4.1 BSEC software .....	24
4.2 Indoor-air-quality .....	26

<b>5. Global memory map and register description</b>	<b>27</b>
5.1 General remarks .....	27
5.2 Memory map .....	28
5.3 Register description .....	29
5.3.1 General control registers.....	29
5.3.2 Temperature, pressure and relative humidity control registers .....	30
5.3.3 <i>Gas control registers</i> .....	32
5.3.4 Data registers .....	35
5.3.5 Status registers .....	36
<b>6. Digital interfaces</b>	<b>38</b>
6.1 Interface selection .....	38
6.2 I <sup>2</sup> C Interface.....	38
6.2.1 I <sup>2</sup> C write .....	39
6.2.2 I <sup>2</sup> C read .....	39
6.3 SPI interface.....	40
6.3.1 SPI write .....	40
6.3.2 SPI read .....	41
6.4 Interface parameter specification .....	41
6.4.1 General interface parameters .....	41
6.4.2 I <sup>2</sup> C timings .....	42
6.4.3 SPI timings .....	43
<b>7. Pin-out and connection diagram</b>	<b>44</b>
7.1 Pin-out.....	44
7.2 Connection diagrams .....	45
7.3 Package dimensions .....	46
7.4 Landing pattern recommendation .....	47
7.5 Marking.....	48
7.5.1 Mass production devices.....	48

7.5.2 Engineering samples.....	48
7.6 Soldering guidelines and reconditioning recommendations .....	49
7.7 Mounting and assembly recommendations .....	49
7.8 Environmental safety.....	50
7.8.1 RoHS.....	50
7.8.2 Halogen content.....	50
7.8.3 Internal package structure.....	50
<b>8. Legal disclaimer</b>	<b>51</b>
8.1 Engineering samples.....	51
8.2 Product use .....	51
8.3 Application examples and hints.....	51
<b>9. Document history and modifications</b>	<b>52</b>

# 1. Specification

If not stated otherwise,

- all values are valid over the full voltage range,
- all minimum/maximum values are given for the full accuracy temperature range
- minimum/maximum values of drifts, offsets and temperature coefficients are  $\pm 3\sigma$  values over lifetime,
- typical values of currents and state machine timings are determined at 25 °C,
- minimum/maximum values of currents are determined using corner lots over complete temperature range, and
- minimum/maximum values of state-machine timings are determined using corner lots over 0–+65 °C temperature range.

Besides the general electrical specifications, the following tables are separated for the gas, pressure, humidity and temperature functions of the BME680.

## 1.1 General Electrical Specification

Table 1: Electrical parameter specification

OPERATING CONDITIONS BME680						
Parameter	Symbol	Condition	Min	Typ	Max	Unit
Supply Voltage Internal Domains <sup>1</sup>	V <sub>DD</sub>	ripple max. 50 mVpp	1.71	1.8	3.6	V
Supply Voltage I/O Domain	V <sub>DDIO</sub>		1.2	1.6	3.6	V
Sleep current	I <sub>DDSL</sub>			0.15	1	μA
Standby current (inactive period of normal mode)	I <sub>DDSB</sub>			0.29	0.8	μA
Current during humidity measurement	I <sub>DDH</sub>	Max value at 85 °C		340	450	μA
Current during pressure measurement	I <sub>DDP</sub>	Max value at -40 °C		714	849	μA
Current during temperature measurement	I <sub>DDT</sub>	Max value at 85 °C		350		μA
Start-up time	t <sub>startup</sub>	Time to first communication after both V <sub>DD</sub> > 1.58 V and V <sub>DDIO</sub> > 0.65 V			2	ms
Power supply rejection ratio (DC)	PSRR	full V <sub>DD</sub> range			±0.01 ±5	%r.H./V Pa/V
Standby time accuracy	Δt <sub>standby</sub>			±5	±25	%

<sup>1</sup> The power efficiency, performance and heat dissipation scales with the applied supply voltage. The BME680 is optimized for 1.8 V.

## 1.2 Gas sensor specification

Table 2 lists the gas sensor specification. All the parameters are deduced from lab measurements under controlled environmental conditions, which are compliant to the ISO16000-29 standard “Test methods for VOC detectors”. Detailed procedure to measure the gas sensor is available in the Application Note AN012: Measurement Instructions for Lab Environment.

Referring to Chapter 4, a software solution (BSEC: Bosch Software Environmental Cluster) is available for the BME680. The software is carefully engineered to seamlessly work with the 4-in-1 integrated sensors inside the BME680. Based on an intelligent algorithm, the BSEC provides an index for air quality (IAQ) output. In principle, this output is in an index that can have values between 0 and 500 with a resolution of 1 to indicate or quantify the quality of the air available in the surrounding. Table 4 lists the IAQ system specification. The detailed classification and color coding of the IAQ index is described in Table 4. Furthermore, the BSEC solution supports different operation modes for the gas sensor to address the necessary power budget and update rate requirements of the end-application.

Unless mentioned otherwise, the specifications are deduced from new sensors that have been operated for at least five days mainly in ambient air and consequently have the same history (i.e. same power mode and exposed to the same environment).

Besides ethanol (EtOH) as a target test gas, the sensors are also tested with breath-VOC (b-VOC). The b-VOC mixture, as listed in Table 5, represents the most important compounds in an exhaled breath of healthy humans. The values are derived from several publications on breath analysis studies. The composition does not contain species which would chemically react to ensure that the mixture is stable for at least 6 months. Furthermore, the composition is also limited to species which can be manufactured in one mixture.

Table 2: Gas sensor parameter specification

Parameter	Symbol	Condition	Min	Typ	Max	Unit
Operational range <sup>1</sup>			-40		85	°C
			10		95	% r.H.
Supply Current during heater operation	I <sub>DD</sub>	Heater target temperature 320 °C, constant operation (V <sub>DD</sub> ≤ 1.8 V, 25°C)	9	12	13	mA
Peak Supply Current	I <sub>Peak</sub>	Occurs within first ms of switching on the hotplate	15	17	18	mA
Average Supply Current (V <sub>DD</sub> ≤ 1.8 V, 25°C)	I <sub>DD,IAQ</sub>	Ultra-low power mode		0.09		mA
		Low power mode		0.9		mA
		Continuous mode		12		mA
Response time <sup>2</sup> (brand-new sensors)	τ <sub>33-63%</sub>	Ultra-low power mode		92		s
	τ <sub>33-63%</sub>	Low power mode		1.4		s
	τ <sub>33-63%</sub>	Continuous mode		0.75		s
Resolution of gas sensor resistance measurement			0.05	0.08	0.11	%
Noise in gas sensor resistance (RMS)	N <sub>R</sub>			1.5		%

<sup>1</sup> The sensors are electrically operable within this range. Actual performance may vary.

<sup>2</sup> Response time of unsoldered, brand-new sensors extracted from the sensors' resistance change in response to a 0.6–60 ppm step of EtOH and a 0.5–15 ppm step of b-VOC at 20 °C, 50% r.H. and atmospheric pressure.

Table 3: IAQ system parameter specification<sup>3</sup>

Parameter	Symbol	Condition	Min	Typ	Max	Unit
Accuracy status <sup>4</sup>	AX <sub>IAQ</sub>	Android compatible	0		3	
IAQ Resolution	IAQ <sub>rs</sub>			1		
IAQ Range	IAQ <sub>rg</sub>		0		500	
Sensor-to-sensor deviation <sup>5</sup>	IAQ <sub>s2s</sub>	All operation modes		±15% ±15		
Durability to siloxanes <sup>6,7,8</sup>	IAQ <sub>s2s</sub>	Sensor-to-sensor deviation		±15% ±15		
	IAQ <sub>drift</sub>	Drift at low & high concentrations		±1% ±4		

Table 4: Index for Air Quality (IAQ) classification and color-coding<sup>9</sup>

IAQ Index	Air Quality	Impact (long-term exposure)	Suggested action
0 – 50	Excellent	Pure air; best for well-being	No measures needed
51 – 100	Good	No irritation or impact on well-being	No measures needed
101 – 150	Lightly polluted	Reduction of well-being possible	Ventilation suggested
151 – 200	Moderately polluted	More significant irritation possible	Increase ventilation with clean air
201 – 250 <sup>9</sup>	Heavily polluted	Exposition might lead to effects like headache depending on type of VOCs	optimize ventilation
251 – 350	Severely polluted	More severe health issue possible if harmful VOC present	Contamination should be identified if level is reached even w/o presence of people; maximize ventilation & reduce attendance
> 351	Extremely polluted	Headaches, additional neurotoxic effects possible	Contamination needs to be identified; avoid presence in room and maximize ventilation

<sup>3</sup> IAQ parameters only apply for the combination of BME680 together with the Bosch Software Environmental Cluster (BSEC) solution (available separately, see Chapter 4)

<sup>4</sup> The accuracy status is equal to zero during the power-on stabilization times of the sensor and is equal to 3 when the sensor achieves best performance

<sup>5</sup> Tested with 0.6–90 ppm of EtOH at 5–40 °C, 20–80% r.H. and atmospheric pressure. Condition is valid after the calibration period of the BSEC algorithm.

<sup>6</sup> Siloxanes are present in a typical indoor environment and can in principle perturb the metal-oxide-based gas sensor performance.

<sup>7</sup> 220 hours of 700 mg/m<sup>3</sup> of octamethylcyclotetrasiloxane (D4) in ambient conditions (i.e. 20 °C and 50% r.H.) simulates the amount of siloxanes in a typical indoor environment over more than 10 years.

<sup>8</sup> Tested with 0.5–15 ppm of b-VOC at 20 °C and 50% r.H. using continuous operation mode for 220 hours of 700 mg/m<sup>3</sup> of octamethylcyclotetrasiloxane (D4).

<sup>9</sup> According to the guidelines issued by the German Federal Environmental Agency, exceeding 25 mg/m<sup>3</sup> of total VOC leads to headaches and further neurotoxic impact on health. The BSEC software auto-calibrates the low and high concentrations applied during testing to IAQ of 25 and 250, respectively.

Table 5: bVOC mixture with Nitrogen as carrier gas

Molar fraction	Compound	Production tolerance	Certified accuracy
5 ppm	Ethane	20 %	5 %
10 ppm	Isoprene /2-methyl-1,3 Butadiene	20 %	5 %
10 ppm	Ethanol	20 %	5 %
50 ppm	Acetone	20 %	5 %
15 ppm	Carbon Monoxide	10 %	2 %

### 1.3 Humidity sensor specification

Table 6: Humidity parameter specification

Parameter	Symbol	Condition	Min	Typ	Max	Unit
Operating Range <sup>10</sup>			-40	25	85	°C
			0		100	% r.H.
Full accuracy range			0		65	°C
			10		90	% r.H.
Supply Current	I <sub>DD,H</sub>	1 Hz forced mode, temperature and humidity measurement		2.1	2.8	µA
Absolute Accuracy	A <sub>H</sub>	20–80 % r.H., 25 °C, including hysteresis		±3		% r.H.
Hysteresis <sup>11</sup>	H <sub>H</sub>	10→90→10 % r.H., 25°C		±1.5		% r.H.
Nonlinearity	NL <sub>H</sub>	10→90 % r.H., 25°C		1.7		% r.H.
Response time to complete 63% of step <sup>12</sup>	τ <sub>0-63%</sub>	N <sub>2</sub> (dry) → 90 % r.H., 25°C		8		s
Resolution	R <sub>H</sub>			0.008		% r.H.
Noise in humidity (RMS)	N <sub>H</sub>	Highest oversampling		0.01		% r.H.
Long-term stability	ΔH <sub>stab</sub>	10–90 % r.H., 25°C		0.5		% r.H./year

<sup>10</sup> When exceeding the operating range (e.g. for soldering), humidity sensing performance is temporarily degraded and reconditioning is recommended as described in Section 7.7. Operating range only for non-condensing environment.

<sup>11</sup> For hysteresis measurement the sequence 0→10→30→50→70→90→70→50→30→10 % r.H. is used. The hysteresis is defined as the maximum difference between measurements at of the same humidity up / down branch and the averaged curve of both branches.

<sup>12</sup> The air-flow in direction to the vent-hole of the device has to be dimensioned in a way that a sufficient air exchange inside to outside will be possible. To observe effects on the response time-scale of the device an air-flow velocity of approximately 1 m/s is needed.

## 1.4 Pressure sensor specification

Table 7: Pressure parameter specification

Parameter	Symbol	Condition	Min	Typ	Max	Unit
Operating temperature range	T <sub>A</sub>	operational	-40	25	85	°C
		full accuracy	0		65	
Operating pressure range	P	full accuracy	300		1100	hPa
Supply current	I <sub>DD,LP</sub>	1 Hz forced mode, pressure and temperature, lowest power		3.1	4.2	μA
Temperature coefficient of offset <sup>13</sup>	TCO <sub>P</sub>	25–40 °C, 900 hPa		±1.3		Pa/K
				±10.9		cm/K
Absolute accuracy pressure	A <sub>p, full</sub>	300–1100 hPa 0–65°C		±0.6		hPa
Relative accuracy pressure	A <sub>rel</sub>	700–900hPa, 25–40 °C, at constant humidity		±0.12		hPa
	A <sub>rel</sub>	900–1100hPa 25–40 °C, at constant humidity		±0.12		hPa
Resolution of pressure output data	R <sub>P</sub>	Highest oversampling		0.18		Pa
Noise in pressure	N <sub>P,fullBW</sub>	Full bandwidth, highest oversampling		1.4		Pa
				11		cm
		Reduced bandwidth, highest oversampling		0.2		Pa
				1.7		cm
Solder drift		Minimum solder height 50μm	-0.5	1.2	+2.0	hPa
Long-term stability <sup>14</sup>	P <sub>stab</sub>	per year		±1.0		hPa
Possible sampling rate	f <sub>sample_P</sub>	Lowest oversampling, see chapter 3.3.2	157	182		Hz

<sup>13</sup> When changing temperature from 25 °C to 40 °C at constant pressure / altitude, the measured pressure / altitude will change by (15×TCO<sub>P</sub>).<sup>14</sup> Long-term stability is specified in the full accuracy operating pressure range 0–65 °C

## 1.5 Temperature sensor specification

Table 8: Temperature parameter specification

Parameter	Symbol	Condition	Min	Typ	Max	Unit
Operating temperature range	$T_A$	operational	-40	25	85	°C
Supply current	$I_{DD,T}$	1 Hz forced mode, temperature measurement only		1.0		μA
Absolute accuracy temperature <sup>15</sup>	$A_{T,25}$	25 °C		±0.5		°C
	$A_{T,full}$	0–65 °C		±1.0		°C
Output resolution	$R_T$	API output resolution		0.01		°C
RMS noise	$N_T$	Lowest oversampling		0.005		°C

<sup>15</sup> Temperature measured by the internal temperature sensor. This temperature value depends on the PCB temperature, sensor element self-heating and ambient temperature and is typically above ambient temperature.

## 2. Absolute maximum ratings

The absolute maximum ratings are determined over the complete temperature range using corner lots. The values are provided in Table 9.

Table 9: Absolute maximum ratings

Parameter	Condition	Min	Max	Unit
Voltage at any supply pin	V <sub>DD</sub> and V <sub>DDIO</sub> pin	-0.3	4.25	V
Voltage at any interface pin		-0.3	V <sub>DDIO</sub> + 0.3	V
Storage temperature	≤ 65% r.H.	-45	+85	°C
Pressure		0	20 000	hPa
ESD	HBM, at any pin		±2	kV
	Machine model		±200	V
Condensation	No power supplied	Allowed		

### 3. Sensor usage

#### 3.1 Sensor modes

The sensor supports low-level power modes: sleep and forced mode. These modes can be selected using the *mode<1:0>* control register (see Section 5.3.1.3). The key differences between the modes are summarized in Table 10.

After a power-up sequence, the sensor automatically starts in sleep mode. If the device is currently performing a measurement, execution of mode switching commands is delayed until the end of the currently running measurement period. It is important to note that, further mode change commands or other write commands to the control registers are ignored until the mode change command has been executed. All control registers should be set to the desired values before writing to the mode register.

Table 10: Low-level operation modes

Operation mode	mode<1:0>	Key features
Sleep	00	<ul style="list-style-type: none"> <li>No measurements are performed</li> <li>Minimal power consumption</li> </ul>
Forced mode	01	<ul style="list-style-type: none"> <li>Single TPHG cycle is performed</li> <li>Sensor automatically returns to sleep mode afterwards</li> <li>Gas sensor heater only operates during gas measurement</li> </ul>

In forced mode, temperature, pressure, humidity and gas conversion are performed sequentially. Such a measurement cycle is abbreviated as TPHG (Temperature, Pressure, Humidity and Gas) in the following descriptions. Up to 10 temperature set-points and heating durations for the gas sensor hot plate can be stored in the sensor registers. In the following, these set-points and the corresponding measurements are identified as G<sub>0</sub> – G<sub>9</sub>. Figure 1 illustrates the handling of these measurement sequences and the gas sensor hot plate is heated for the forced mode.

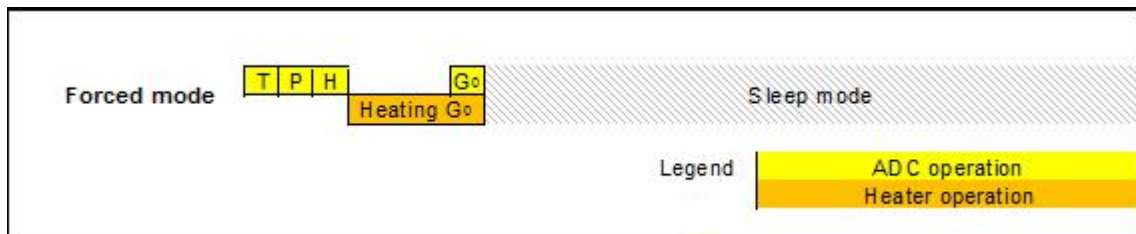

Figure 1: Sequence of ADC and gas sensor heater operation

## 3.2 Sensor configuration

### 3.2.1 Quick start

The sensor is configured by writing to a set of control registers (see Chapter 5 for a detailed list of all available registers and their descriptions). This section illustrates, with the help of a basic step-by-step example, how to configure the sensor for simple forced mode measurements with a single heater set-point. For a more detailed description of the measurement flow, please refer to Section 3.3.

In this example, the sensor will be configured to use 2x oversampling for its temperature measurements, 16x oversampling for the pressure signal, and 1x oversampling for humidity. Moreover, the gas sensor hot plate will be configured to be heated for 100 ms at 300 °C before the gas measurement is performed.

First, the user must configure the oversampling settings for temperature, pressure and humidity by setting the control registers *osrs\_t<2:0>* and *osrs\_h<2:0>*, respectively. Supported settings range from 16x oversampling down to 0x, which is equivalent to skipping the corresponding sub-measurement. See Section 5.3.2 for further details.

1. Set humidity oversampling to 1x by writing 0b001 to *osrs\_h<2:0>*
2. Set temperature oversampling to 2x by writing 0b010 to *osrs\_t<2:0>*
3. Set pressure oversampling to 16x by writing 0b101 to *osrs\_p<2:0>*

It is highly recommended to set first *osrs\_h<2:0>* followed by *osrs\_t<2:0>* and *osrs\_p<2:0>* in one write command (see Section 3.3).

Next, the user shall set at least one gas sensor hot plate temperature set-point and heating duration. Up to 10 heating duration can be configured through the control registers *gas\_wait\_x<7:0>*, where x ranges from 0 to 9. See Section 5.3.3 for definition of register content. The corresponding heater set-points are stored in the registers *res\_heat\_x<7:0>*. Section 3.3.5 explains how to convert the target heater temperature, e.g. 300 °C, into a register code. For forced mode operation, the used heater set point is selected by setting the control register *nb\_conv<3:0>* to the heater profile to be used, e.g. to use *gas\_wait\_0<7:0>* and *res\_heat\_0<7:0>*, *nb\_conv<3:0>* shall be set to 0x0. Finally, gas functionality shall be enabled by setting the *run\_gas\_l* bit to 1.

4. Set *gas\_wait\_0<7:0>* to 0x59 to select 100 ms heat up duration
5. Set the corresponding heater set-point by writing the target heater resistance to *res\_heat\_0<7:0>*
6. Set *nb\_conv<3:0>* to 0x0 to select the previously defined heater settings
7. Set *run\_gas\_l* to 1 to enable gas measurements

Now, a single forced mode measurement with the above settings can be triggered by writing 0b01 to *mode<1:0>*. For more details on data readout, please see Section 5.3.1.3.

8. Set *mode<1:0>* to 0b01 to trigger a single measurement.

### 3.2.2 Sensor configuration flow

Picture 2 illustrates which control registers must be set. For details on the individual control registers, please refer to Chapter 5. Moreover, details on the measurement flow for the individual modes can be found in Section 3.3.

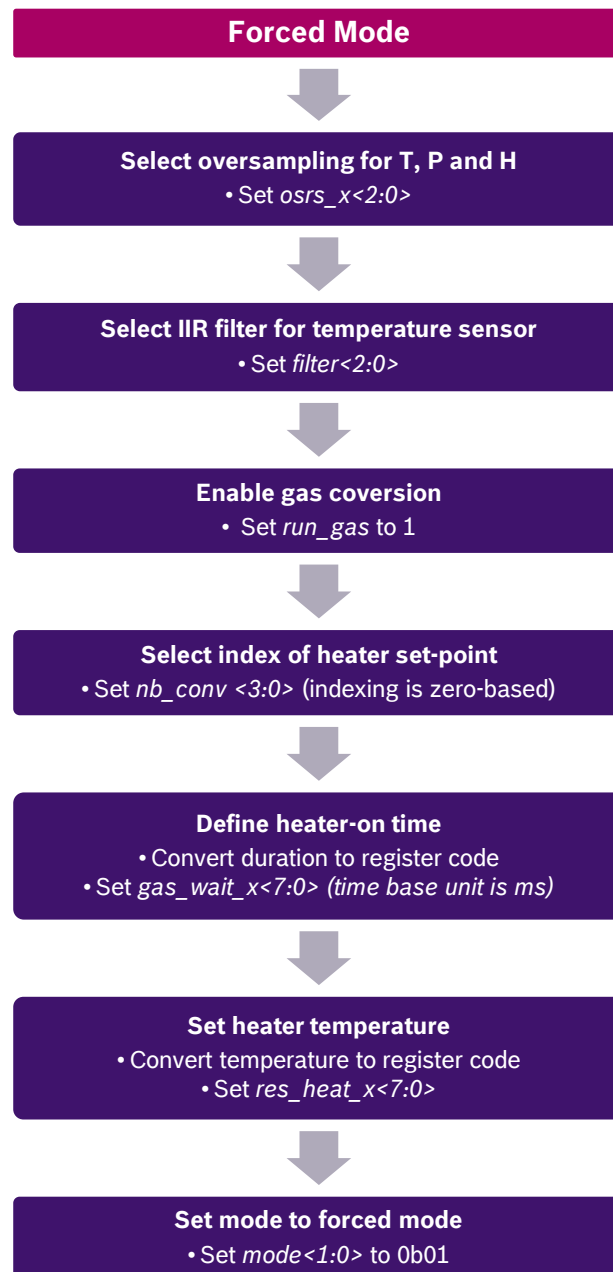

Picture 2: Sensor configuration flow

### 3.3 Measurement flow

Referring to Figure 1, the BME680 measurement period consists of a temperature, pressure and humidity measurement with selectable oversampling. Moreover, it contains a heating phase for the gas sensor hot plate as well as a measurement of the gas sensor resistance.

After the measurement period, the pressure and temperature data can be passed through an optional IIR filter, which removes short-term fluctuations. For humidity and gas, such a filter is not needed and has not been implemented.

#### 3.3.1 Temperature measurement

Temperature measurement can be enabled or skipped. Skipping the measurement is typically not recommended since temperature information is used to compensate temperature influences in the other parameters. When enabled, several oversampling options exist. The temperature measurement is controlled by the `osrs_t<2:0>` setting which is detailed in Section 5.3.2.2. For the temperature measurement, oversampling is possible to reduce the noise. The resolution of the temperature data depends on the IIR filter (see Section 5.3.2.4) and the oversampling setting:

- When the IIR filter is enabled, the temperature resolution is 20 bit
- When the IIR filter is disabled, the temperature resolution is  $16 + (osrs\_t - 1)$  bit, e.g. 18 bit when `osrs_t` is set to '3'

Using the variables listed in Table 11, the following code will calculate the compensated temperature value (in degrees Celsius). It is, however, recommended to use the sensor API available on github (Chapter 4) for a friendlier user experience.

##### Floating point:

```
var1 = (((double)temp_adc / 16384.0) - ((double)par_t1 / 1024.0)) * (double)par_t2;
var2 = (((double)temp_adc / 131072.0) - ((double)par_t1 / 8192.0)) *
      (((double)temp_adc / 131072.0) - ((double)par_t1 / 8192.0)) *
      ((double)par_t3 * 16.0);
t_fine = var1 + var2;
temp_comp = t_fine / 5120.0;
```

##### Integer:

```
var1 = ((int32_t)temp_adc >> 3) - ((int32_t)par_t1 << 1);
var2 = (var1 * (int32_t)par_t2) >> 11;
var3 = (((var1 >> 1) * (var1 >> 1)) >> 12) * ((int32_t)par_t3 << 4) >> 14;
t_fine = var2 + var3;
temp_comp = ((t_fine * 5) + 128) >> 8;
```

where

- `par_t1`, `par_t2` and `par_t3` are calibration parameters,
- `temp_adc` is the raw temperature output data,
- `temp_comp` is the compensated temperature output data in degrees Celsius.

Table 11: Variable names and register addresses for *temp\_comp* calculation

Variable name	Register address (LSB / MSB)
par_t1	0xE9 / 0xEA
par_t2	0x8A / 0x8B
par_t3	0x8C
temp_adc	0x24<7:4> / 0x23 / 0x22

### 3.3.2 Pressure measurement

Pressure measurement can be enabled or skipped. When enabled, several oversampling options exist. The pressure measurement is controlled by the `osrs_p<2:0>` setting which is detailed in Section 5.3.2. For the pressure measurement, oversampling is possible to reduce noise. The resolution of the pressure data depends on the IIR filter (see Section 5.3.2.4) and the oversampling setting:

- When the IIR filter is enabled, the pressure resolution is 20 bit
- When the IIR filter is disabled, the pressure resolution is 16 + (`osrs_p` – 1) bit, e.g. 18 bit when `osrs_p` is set to ‘3’

Using the variables listed in Table 12, the following code will calculate the compensated pressure value (in Pascal). It is, however, recommended to use the sensor API available on github (Chapter 4) for a friendlier user experience.

#### Floating point:

```
var1 = ((double)t_fine / 2.0) - 64000.0;
var2 = var1 * var1 * ((double)par_p6 / 131072.0);
var2 = var2 + (var1 * (double)par_p5 * 2.0);
var2 = (var2 / 4.0) + ((double)par_p4 * 65536.0);
var1 = (((double)par_p3 * var1_p * var1) / 16384.0) +
        ((double)par_p2 * var1_p) / 524288.0;
var1 = (1.0 + (var1 / 32768.0)) * (double)par_p1;
press_comp = 1048576.0 - (double)press_adc;
press_comp = ((press_comp - (var2_p / 4096.0)) * 6250.0) / var1;
var1 = ((double)par_p9 * press_comp * press_comp) / 2147483648.0;
var2 = press_comp * ((double)par_p8 / 32768.0);
var3 = (press_comp / 256.0) * (press_comp / 256.0) *
        (press_comp / 256.0) * (par_p10 / 131072.0);
press_comp = press_comp + (var1_p + var2_p + var3_p +
        ((double)par_p7 * 128.0)) / 16.0;
```

#### Integer:

```
var1 = ((int32_t)t_fine >> 1) - 64000;
var2 = (((var1 >> 2) * (var1 >> 2)) >> 11) * (int32_t)par_p6 >> 2;
var2 = var2 + ((var1 * (int32_t)par_p5) << 1);
var2 = (var2 >> 2) + ((int32_t)par_p4 << 16);
var1 = (((var1 >> 2) * (var1 >> 2)) >> 13) *
        ((int32_t)par_p3 << 5) >> 3) + (((int32_t)par_p2 * var1) >> 1);
```

```

var1 = var1 >> 18;
var1 = ((32768 + var1) * (int32_t)par_p1) >> 15;
press_comp = 1048576 - press_raw;
press_comp = (uint32_t)((press_comp - (var2 >> 12)) * ((uint32_t)3125));
if (press_comp >= (1 << 30))
    press_comp = ((press_comp / (uint32_t)var1) << 1);
else
    press_comp = ((press_comp << 1) / (uint32_t)var1);
var1 = ((int32_t)par_p9 * (int32_t)((press_comp >> 3) *
    (press_comp >> 3)) >> 13)) >> 12;
var2 = ((int32_t)(press_comp >> 2) * (int32_t)par_p8) >> 13;
var3 = ((int32_t)(press_comp >> 8) * (int32_t)(press_comp >> 8) *
    (int32_t)(press_comp >> 8) * (int32_t)par_p10) >> 17;
press_comp = (int32_t)(press_comp) +
    ((var1 + var2 + var3 + ((int32_t)par_p7 << 7)) >> 4);

```

where

- *par\_p1, par\_p2, ..., par\_p10* are calibration parameters,
- *press\_adc* is the raw pressure output data,
- *press\_comp* is the compensated pressure output data in Pascal.

Table 12: Variable names and register addresses for *press\_comp* calculation

Variable name	Register address (LSB / MSB)
par_p1	0x8E / 0x8F
par_p2	0x90 / 0x91
par_p3	0x92
par_p4	0x94 / 0x95
par_p5	0x96 / 0x97
par_p6	0x99
par_p7	0x98
par_p8	0x9C / 0x9D
par_p9	0x9E / 0x9F
par_p10	0xA0
press_adc	0x21<7:4> / 0x20 / 0x1F

### 3.3.3 Humidity measurement

The humidity measurement can be enabled or skipped. When enabled, several oversampling options exist. The humidity measurement is controlled by the *osrs\_h*<2:0> setting, which is described in detail in Section 5.3.2.1. For the humidity measurement, oversampling is possible to reduce noise. The resolution of the humidity measurement is fixed at 16 bit ADC output.

Using the variables listed in Table 13, the following code will calculate the compensated humidity value (in percent). It is, however, recommended to use the sensor API available on github (Chapter 4) for a friendlier user experience.

#### Floating point:

```
var1 = hum_adc - (((double)par_h1 * 16.0) + (((double)par_h3 / 2.0) * temp_comp));
var2 = var1 * (((double)par_h2 / 262144.0) * (1.0 + (((double)par_h4 / 16384.0) *
temp_comp) + (((double)par_h5 / 1048576.0) * temp_comp * temp_comp)));
var3 = (double)par_h6 / 16384.0;
var4 = (double)par_h7 / 2097152.0;
hum_comp = var2 + ((var3 + (var4 * temp_comp)) * var2 * var2);
```

#### Integer:

```
temp_scaled = (int32_t)temp_comp;
var1 = (int32_t)hum_adc - (int32_t)((int32_t)par_h1 << 4) -
(((temp_scaled * (int32_t)par_h3) / ((int32_t)100)) >> 1);
var2 = ((int32_t)par_h2 * ((temp_scaled *
(int32_t)par_h4) / ((int32_t)100)) +
(((temp_scaled * (temp_scaled * (int32_t)par_h5) /
((int32_t)100))) >> 6) / ((int32_t)100) + ((int32_t)(1 << 14)))) >> 10;
var3 = var1 * var2;
var4 = (((int32_t)par_h6 << 7) +
((temp_scaled * (int32_t)par_h7) / ((int32_t)100))) >> 4;
var5 = ((var3 >> 14) * (var3 >> 14)) >> 10;
var6 = (var4 * var5) >> 1;
hum_comp = (var3 + var6) >> 12;
hum_comp = (((var3 + var6) >> 10) * ((int32_t) 1000)) >> 12;
```

where

- *par\_h1, par\_h2, ..., par\_h7* are calibration parameters,
- *hum\_adc* is the raw humidity output data,
- *hum\_comp* is the compensated humidity output data in percent.

Table 13: Variable names and register addresses for *hum\_comp* calculation

Variable name	Register address (LSB / MSB)
par_h1	0xE2<7:4> / 0xE3
par_h2	0xE2<7:4> / 0xE1
par_h3	0xE4
par_h4	0xE5
par_h5	0xE6
par_h6	0xE7
par_h7	0xE8
hum_adc	0x26 / 0x25

### 3.3.4 IIR filter

The environmental pressure is subject to many short-term changes, caused external disturbances. To suppress disturbances (e.g. slamming of door or wind blowing into the sensor) in the output data without causing additional interface traffic and processor work load, the BME680 features an internal IIR filter (see Section 5.3.2.4). It effectively reduces the bandwidth of the temperature and pressure output signals and increases the resolution of the output data to 20 bit, noting that the humidity and gas values inside the sensor does not fluctuate rapidly and does not require low pass filtering. The output of a next measurement step is filtered using the following formula:

$$x_{filt}[n] = \frac{x_{filt}[n-1] \cdot (c-1) + x_{ADC}}{c}$$

$x_{filt}[n-1]$  is the data coming from the current filter memory, and  $x_{ADC}$  is the data coming from current ADC acquisition.  $x_{filt}[n]$  denotes the new value of filter memory and the value that will be sent to the output registers.

The IIR filter can be configured to different filter coefficients, which slows down the response to the sensor inputs. Note that the response time with enabled IIR filter depends on the number of samples generated, which means that the data output rate must be known to calculate the actual response time.

When writing to the register *filter*, the filter is reset. The next ADC values will pass through the filter unchanged and become the initial memory values for the filter. If temperature or pressure measurements are skipped, the corresponding filter memory will be kept unchanged even though the output registers are set to 0x80000. When the previously skipped measurement is re-enabled, the output will be filtered using the filter memory from the last time when the measurement was not skipped. If this is not desired, please write to the filter register in order to re-initialize the filter.

### 3.3.5 Gas sensor heating and measurement

The operation of the gas sensing part of BME680 involves two steps:

1. Heating the gas sensor hot plate to a target temperature (typically between 200 °C and 400 °C) and keep that temperature for a certain duration of time.
2. Measuring the resistance of the gas sensitive layer.

Up to 10 different hot plate temperature set points can be configured by setting the registers *res\_heat\_x<7:0>*, where  $x = 0 \dots 9$ . The internal heater control loop operates on the resistance of the heater structure. Hence, the user first needs to convert the target temperature into a device specific target resistance before writing the resulting register code into the sensor memory map.

Using the variables listed Table 14: Variable names and register addresses for *res\_heat\_x* calculation, the following code will calculate register code that to be written to *res\_heat\_x<7:0>*. It is, however, recommended to use the sensor API available on github (Chapter 4) for a friendlier user experience.

#### Floating point:

```
var1 = ((double)par_g1 / 16.0) + 49.0;
var2 = (((double)par_g2 / 32768.0) * 0.0005) + 0.00235;
var3 = (double)par_g3 / 1024.0;
var4 = var1 * (1.0 + (var2 * (double) target_temp));
var5 = var4 + (var3 * (double) amb_temp);
res_heat_x = (uint8_t)(3.4 * ((var5 * (4.0 / (4.0 + (double)res_heat_range)) * (1.0/(1.0 + ((double)res_heat_val * 0.002)))) - 25));
```

#### Integer:

```
var1 = (((int32_t)amb_temp * par_g3) / 10) << 8;
var2 = (par_g1 + 784) * (((((par_g2 + 154009) * target_temp * 5) / 100) + 3276800) / 10);
var3 = var1 + (var2 >> 1);
var4 = (var3 / (res_heat_range + 4));
var5 = (131 * res_heat_val) + 65536;
res_heat_x100 = (int32_t)((var4 / var5) - 250) * 34;
res_heat_x = (uint8_t)((res_heat_x100 + 50) / 100);
```

where

- *par\_g1*, *par\_g2*, and *par\_g3* are calibration parameters,
- *target\_temp* is the target heater temperature in degree Celsius,
- *amb\_temp* is the ambient temperature (hardcoded or read from temperature sensor),
- *var5* is the target heater resistance in Ohm,
- *res\_heat\_x* is the decimal value that needs to be stored in register, where 'x' corresponds to the temperature profile number between 0 and 9,
- *res\_heat\_range* is the heater range stored in register address 0x02 <5:4>, and
- *res\_heat\_val* is the heater resistance correction factor stored in register address 0x00 (signed, value from -128 to 127).

Table 14: Variable names and register addresses for *res\_heat\_x* calculation

Variable name	Register address (LSB / MSB)
<i>par_g1</i>	0xED
<i>par_g2</i>	0xEB/0xEC
<i>par_g3</i>	0xEE
<i>res_heat_range</i>	0x02 <5:4>
<i>res_heat_val</i>	0x00

For each of the 10 temperature set-points, the heating duration must be specified. Referring to Figure 1, the heating phase starts after the temperature, pressure and humidity measurements are complete. This means there is no heating in parallel to these measurements, which is desirable to minimize undesired cross-influences between the various sensor components.

The heating duration is specified by writing to the corresponding *gas\_wait\_x*<7:0> control register. Heating durations between 1 ms and 4032 ms can be configured. In practice, approximately 20–30 ms are necessary for the heater to reach the intended target temperature.

### 3.4 Data readout

The procedure goes as follows, the *new\_data\_x* bit (see Section 5.3.5.1) can be checked to see if a new data is generated. If gas measurements are performed the *gas\_valid\_r* (see Section 5.3.5.5) and *heat\_stab\_r* (see Section 5.3.5.6) status bits of the respectively field should be checked to ensure that the gas measurement was successful. If *heat\_stab\_r* is zero, it indicates that either the heating time was not sufficient to allow the sensor to reach to configured target temperature or that the target temperature was too high for the sensor to reach.

After the uncompensated values of temperature, pressure and humidity have been read, the actual humidity, pressure and temperature need to be calculated using the compensation parameters stored in the device. Please refer to the BME6xy API for more details.

#### 3.4.1 Gas resistance readout

Readout of gas resistance ADC value and calculation of gas resistance consists of 3 steps

1. Read gas ADC value (*gas\_adc*) and gas ADC range (*gas\_range*) (see Section 5.3.4)
2. Read range switching error from register address 0x04 <7:4> (signed 4 bit)
3. Convert ADC value into gas resistance in ohm

Using the variables listed in Table 15 and Table 16, the conversion is done as follows:

Floating point:

```
var1 = (1340.0 + 5.0 * range_switching_error) * const_array1[gas_range];
gas_res = var1 * const_array2[gas_range] / (gas_adc - 512.0 + var1);
```

Integer:

```
int64_t var1 = (int64_t)((((1340 + (5 * (int64_t)range_switching_error)) *
((int64_t)const_array1_int[gas_range])) >> 16);
```

```
int64_t var2 = (int64_t)(gas_adc << 15) - (int64_t)(1 << 24) + var1;
```

```
int32_t gas_res = (int32_t)((((int64_t)(const_array2_int[gas_range] * (int64_t)var1) >> 9) + (var2 >>
1)) / var2);
```

where

- *gas\_adc* is the raw gas resistance output data (i.e. ADC value),
- *gas\_range* is the ADC range of the measured gas resistance,
- *range\_switching\_error* is a calibration parameter,
- *gas\_res* is the compensated gas resistance output data in Ohms.

Table 15: Variable names and register addresses for *gas\_res* calculation

Variable name	Register address (LSB / MSB)
<i>gas_adc</i>	0x2B<7:6> / 0x2A
<i>gas_range</i>	0x2B<3:0>
<i>range_switching_error</i>	0x04

Table 16: List of gas ranges and corresponding constants used for the resistance calculation

<i>gas_range_r</i>	Constants to be integrated into the driver			
	Floating point		Integer	
	<i>const_array1</i>	<i>const_array2</i>	<i>const_array1_int</i>	<i>const_array2_int</i>
0	1	8000000	2147483647	4096000000
1	1	4000000	2147483647	2048000000
2	1	2000000	2147483647	1024000000
3	1	1000000	2147483647	512000000
4	1	499500.4995	2147483647	255744255
5	0.99	248262.1648	2126008810	127110228
6	1	125000	2147483647	64000000
7	0.992	63004.03226	2130303777	32258064
8	1	31281.28128	2147483647	16016016
9	1	15625	2147483647	8000000
10	0.998	7812.5	2143188679	4000000
11	0.995	3906.25	2136746228	2000000
12	1	1953.125	2147483647	1000000
13	0.99	976.5625	2126008810	500000
14	1	488.28125	2147483647	250000
15	1	244.140625	2147483647	125000

## 4. Software and use cases

### 4.1 BSEC software

BME680 sensor is intended to be used together with Bosch Software Environmental Cluster (BSEC) solution and BME6xy sensor API to unlock its full potential. The BSEC software features intelligent algorithms which enable use cases such as indoor-air-quality monitoring using the BME680.

Bosch Sensortec BSEC software is available as a closed source binary which will be made available via a Software License Agreement (SLA) on the Bosch Sensortec website ([https://www.bosch-sensortec.com/bst/products/all\\_products/BSEC](https://www.bosch-sensortec.com/bst/products/all_products/BSEC)). Sensor API covers basic sensor communication and data compensation functions and is available as open-source code from Github ([https://github.com/BoschSensortec/BME680\\_driver](https://github.com/BoschSensortec/BME680_driver)).

The key features of the hardware-software system are:

- Calculation of ambient air temperature outside of the device (e.g. phone)
- Calculation of ambient relative humidity outside of the device
- Calculation of index for air quality (IAQ) level outside of the device

Moreover, the software algorithms handle humidity compensation, baseline as well as long-term drift correction of the gas sensor signal.

Different power modes for the gas sensor and corresponding data rates are supported by the software solution:

- **Ultra low power (ULP)** mode is designed for battery-powered and/or frequency-coupled devices over extended periods of time. This mode features an update rate of 300 seconds and an average current consumption of <0.1 mA
- **Quick Ultra-low power (q-ULP)** has a 3 s data rate for Temperature, pressure and humidity w/o significantly increasing the power consumption compared to ULP.
- **Low power (LP)** mode that is designed for interactive applications where the air quality is tracked and observed at a higher update rate of 3 seconds with a current consumption of <1 mA
- **Continuous (CONT)** mode provides an update rate of 1 Hz and shall only be used short-term for use cases that incorporate very fast events or stimulus.

Table 17: BSEC gas sensor power-modes

BSEC power mode	Update rate	Average current consumption
Ultra-low power mode (ULP)	3.3 mHz	0.09 mA
quick Ultra-low power mode (q-ULP)	0.33 Hz (T, p, h) / 3.3 mHz (IAQ)	0.1 mA
Low power mode (LP)	0.33 Hz	0.9 mA
Continuous mode (for testing purposes only)	1 Hz	12 mA

The BSEC software suite can be downloaded from the Bosch Sensortec website:

[https://www.bosch-sensortec.com/bst/products/all\\_products/BSEC](https://www.bosch-sensortec.com/bst/products/all_products/BSEC)

The following table describes the available outputs of BSEC. Full descriptions of the outputs and the available interfaces are available in the integration guide shipped together with the BSEC software.

Table 18: BSEC outputs

Output	Description
Raw pressure	Raw data from sensor API bypassed to BSEC output
Raw temperature	Raw data from sensor API bypassed to BSEC output
Raw relative humidity	Raw data from sensor API bypassed to BSEC output
Raw gas resistance	Raw data from sensor API bypassed to BSEC output
Sensor-compensated temperature (°C)	Temperature which is compensated for internal cross-influences caused by the BME sensor
Sensor-compensated relative humidity (%)	Relative humidity which is compensated for internal cross-influences caused by the BME sensor
Sensor-compensated gas resistance (Ohm)	Raw gas resistance compensated by temperature and humidity influences.
IAQ (0-500)	Index for Air Quality, especially recommended for mobile devices, since the auto-trim algorithm automatically adapts to different environments.
Static IAQ ("s-IAQ")	"Static" Index for Air Quality, especially recommended for stationary devices (w/ o auto-trimming algorithm)
CO <sub>2</sub> equivalents (ppm)	Estimation of the CO <sub>2</sub> level in ppm. The sensor does not directly measure CO <sub>2</sub> , but derives this from the average correlation between VOCs and CO <sub>2</sub> in human's exhaled breath.
b-VOC equivalents (ppm)	Conversion into breath-VOC equivalents in ppm concentration. The scaling is derived from lab tests with the b-VOC gas mixture described in  Table 5.
Accuracy status (0-3)	Accuracy status of IAQ
Stabilization time status	Indicates if the sensor is undergoing initial stabilization during its first use after production
Run in status	Indicates when the sensor is ready after switch-on
Gas (%)	Alternative indicator for air pollution which rates the current raw gas resistance value based on the individual sensor history: 0% = "lowest air pollution ever measured" 100% = "highest air pollution level ever measured"

## 4.2 Indoor-air-quality

BME680 is a metal oxide-based sensor that detects VOCs by adsorption (and subsequent oxidation/reduction) on its sensitive layer. Thus, BME680 reacts to most volatile compounds polluting indoor air (one exception is for instance CO<sub>2</sub>). In contrast to sensors selective for one specific component, BME680 is capable of measuring the sum of VOCs/contaminants in the surrounding air. This enables BME680 to detect e.g. outgassing from paint, furniture and/or garbage, high VOC levels due to cooking, food consumption, exhaled breath and/or sweating.

As a raw signal, BME680 will output resistance values and its changes due to varying VOC concentrations (the higher the concentration of reducing VOCs, the lower the resistance and vice versa). Since this raw signal is influenced by parameters other than VOC concentration (e.g. humidity level), the raw values are transformed to an index for air quality (IAQ) by smart algorithms inside BSEC.

The IAQ scale ranges from 0 (clean air) to 500 (heavily polluted air). During operation, the algorithms automatically calibrate and adapt themselves to the typical environments where the sensor is operated (e.g., home, workplace, inside a car, etc.). This automatic background calibration ensures that users experience consistent IAQ performance. The calibration process considers the recent measurement history (typ. up to four days) to ensure that IAQ ~ 25 corresponds to “typical good” air and IAQ ~ 250 indicates “typical polluted” air.

## 5. Global memory map and register description

### 5.1 General remarks

Communication with the device is performed by reading from and writing to registers. Registers have a width of 8 bits. If I<sup>2</sup>C is used, 8-bit addressing is utilized. If SPI is used, 7-bit address is only available for register access. For details on the interface, consult Chapter 6.

In SPI mode complete memory map is accessed using page 0 and page 1. Register *spi\_mem\_page* is used for page selection. After power-on, *spi\_mem\_page* is in its reset state and page 0 (0x80 to 0xFF) will be active. Page 1 (0x00 to 0x7F) will be active on setting *spi\_mem\_page* to 1.

Global memory map consists of calibration registers, control registers, data registers, status registers and reserved registers. There are, however, several registers which are reserved. Accordingly, they should not be written to and no specific value is guaranteed when they are read.

Table 19: Memory map page selection

Digital Interface	Register address range	Register <i>spi_mem_page</i>	Memory Page
I <sup>2</sup> C	0x00 to 0xFF	Not Applicable	Not Applicable
SPI	0x80 to 0xFF	0 (default; power on state)	Page 0
SPI	0x00 to 0x7F	1	Page 1

## 5.2 Memory map

The memory map is given in Table 20, noting that not all reserved registers are depicted.

Table 20: Memory map

Register name	I <sup>2</sup> C		SPI		Bit 7	Bit 6	Bit 5	Bit 4	Bit 3	Bit 2	Bit 1	Bit 0	Reset state
	Adr	Adr	Pg										
status	73h	73h	1					spi_mem_page					00h
Reset	E0h	60h	0	reset<7:0>									00h
Id	D0h	50h	0	chip_id<7:0>									61h
Config	75h	75h	1					filter<2:0>			spi_3w_en		00h
Ctrl_meas	74h	74h	1	osrs_t<2:0>			osrs_p<2:0>			mode<1:0>			00h
Ctrl_hum	72h	72h	1	spi_3w_int_en						osrs_h<2:0>			00h
Ctrl_gas_1	71h	71h	1			run_gas		nb_conv<3:0>				00h	
Ctrl_gas_0	70h	70h	1					heat_off					00h
Gas_wait_x	6Dh...64h	6Dh...64h	1	gas_wait_9<7:0> downto gas_wait_0<7:0>									00h
Res_heat_x	63h...5Ah	63h...5Ah	1	res_heat_9<7:0> downto res_heat_0<7:0>									00h
Idac_heat_x	59h...50h	59h...50h	1	idac_heat_9<7:0> downto idac_heat_0<7:0>									00h
gas_r_lsb	2Bh	2Bh	1	gas_r<1:0>		gas_valid_r	heat_stab_r	gas_range_r					00h
gas_r_msb	2Ah	2Ah	1	gas_r<9:2>									00h
hum_lsb	26h	26h	1	hum_lsb<7:0>									00h
hum_msb	25h	25h	1	hum_msb<7:0>									80h
temp_xlsb	24h	24h	1	temp_xlsb<7:4>				0	0	0	0	00h	
temp_lsb	23h	23h	1	temp_lsb<7:0>									00h
temp_msb	22h	22h	1	temp_msb<7:0>									80h
press_xlsb	21h	21h	1	press_xlsb<7:4>				0	0	0	0	00h	
press_lsb	20h	20h	1	press_lsb<7:0>									00h
press_msb	1Fh	1Fh	1	press_msb<7:0>									80h
eas_status_0	1Dh	1Dh	1	new_data_0	gas_measuring	measuring			gas_meas_index_0<3:0>				00h

Registers	Color/Type
Reserved	Do not change
Status register	Read only
Data register	Read only
Control register	Read/write

## 5.3 Register description

### 5.3.1 General control registers

#### 5.3.1.1 SPI 3 wire interrupt enable – *spi\_3w\_int\_en*

Register Name	Address	Content<bit position>	Description
ctrl_hum	0x72	spi_3w_int_en <6>	New data interrupt can be enabled if the device is in SPI 3 wire mode and <i>pi_3w_int_en=1</i> . The new data interrupt is then indicated on the SDO pad.

#### 5.3.1.2 SPI 3 wire enable – *spi\_3w\_en*

Register Name	Address	Content<bit position>	Description
config	0x75	spi_3w_en<0>	Enable SPI 3 wire mode

#### 5.3.1.3 Mode Selection – *mode*

The operation modes of the sensor can be controlled by the register *mode* as specified below.

Register Name	Address	Content<bit position>	Description
ctrl_meas	0x74	mode<1:0>	Select sensor power mode as shown in the following table

mode<1:0>	Mode
00	Sleep mode
01	Forced mode

#### 5.3.1.4 SPI memory map page selection – *spi\_mem\_page*

In SPI mode complete memory page is accessed using page 0 & page 1. Register *spi\_mem\_page* is used for page selection. After power-on, *spi\_mem\_page* is in its reset state and page 0(0x80 to 0xFF) will be active. Page1 (0x00 to 0x7F) will be active on setting *spi\_mem\_page*. Please refer Table 19 for better understanding.

Register Name	Address	Content<bit position>	Description
status	0x73(Page 0/1)	spi_mem_page <4>	Selects memory map page in SPI mode

### 5.3.1.5 Reset – reset

Writing 0xB6 to this register initiates a soft-reset procedure, which has the same effect like power-on reset. The default value stored in this register is 0x00.

Register Name	Address	Content<bit position>	Description
reset	0x60 (Page 0 in SPI mode) 0xE0 in I <sup>2</sup> C	reset<7:0>	Resets the device

### 5.3.1.6 Chip id – chip\_id

Register Name	Address	Content<bit position>	Description
Id	0x50(Page 0 in SPI mode) 0xD0 in I <sup>2</sup> C	chip_id<7:0>	Chip id of the device

## 5.3.2 Temperature, pressure and relative humidity control registers

### 5.3.2.1 Humidity sensor over sampling control – osrs\_h

Register Name	Address	Content<bit position>	Description
ctrl_hum	0x72	osrs_h<2:0>	Controls over sampling setting of humidity sensor as described in the following table

osrs_h<2:0>	Humidity oversampling
000	Skipped (output set to 0x8000)
001	oversampling ×1
010	oversampling ×2
011	oversampling ×4
100	oversampling ×8
101, Others	oversampling ×16

### 5.3.2.2 Over sampling setting – Temperature data – osrs\_t

Register Name	Address	Content<bit position>	Description
ctrl_meas	0x74	osrs_t<7:5>	Temperature oversampling settings as shown in the following table

osrs_t<2:0>	Temperature oversampling
000	Skipped (output set to 0x8000)
001	oversampling ×1
010	oversampling ×2
011	oversampling ×4
100	oversampling ×8
101, Others	oversampling ×16

5.3.2.3 Over sampling setting – Pressure data – *osrs\_p*

Register Name	Address	Content<bit position>	Description
ctrl_meas	0x74	osrs_p<4:2>	Pressure oversampling settings as shown in the following table

osrs_p<2:0>	Pressure oversampling
000	Skipped (output set to 0x8000)
001	oversampling ×1
010	oversampling ×2
011	oversampling ×4
100	oversampling ×8
101, Others	oversampling ×16

5.3.2.4 IIR filter control – *filter*

IIR filter applies to temperature and pressure data but not to humidity and gas data. The data coming from the ADC are filtered and then loaded into the data registers. The temperature and pressure result registers are updated together at the same time at the end of the measurement. IIR filter output resolution is 20 bits. The result registers are reset to value 0x80000 when the temperature and/or pressure measurements have been skipped (*osrs\_x*="000"). The appropriate filter memory is kept unchanged (the value from the last measurement is kept). When the appropriate OSRS register is set back to nonzero, then the first value stored to the result registers are filtered.

Register Name	Address	Content<bit position>	Description
config	0x75	filter<4:2>	IIR filter settings as shown in the following table

filter<2:0>	Filter coefficient
000	0
001	1
010	3
011	7
100	15
101	31
110	63
111	127

### 5.3.3 Gas control registers

The sensor can have 10 programmable gas sensor heater set-points. A set-point consists of a target heater resistance, heater-on time and optionally an initial heater current.

#### 5.3.3.1 Heater current - *idac\_heat\_x*

BME680 contains a heater control block that will inject enough current into the heater resistance to achieve the requested heater temperature. There is a control loop which periodically measures heater resistance value and adapts the value of current injected from a DAC.

The heater operation could be speeded up by setting an initial heater current for a target heater temperature by using register *idac\_heat\_x<7:0>*. This step is optional since the control loop will find the current after a few iterations anyway. The current injected to the heater in mA can be calculated by:  $(idac\_heat\_7\_1 + 1) / 8$ , where *idac\_heat\_7\_1* is the decimal value stored in *idac\_heat<7:1>* (unsigned, value from 0 to 127).

Heater set-point	Register name	Address	Content	Description
0...9	<i>idac_heat_x</i> <i>x is from 0 to 9</i>	0x50...0x59	<i>idac_heat_x&lt;7:0&gt;</i> <i>x is from 0 to 9</i>	<i>idac_heat</i> of particular heater set point

#### 5.3.3.2 Target heater resistance - *res\_heat\_x*

Target heater resistance is programmed by user through *res\_heat\_x<7:0>* registers. The definition of *res\_heat\_x* is given in Section 3.3.5.

Heater set-point	Register name	Address	Content	Description
0...9	<i>res_wait_x</i> <i>x is from 0 to 9</i>	0x5A...0x63	<i>res_heat_x&lt;7:0&gt;</i> <i>x is from 0 to 9</i>	Decimal value that needs to be stored for achieving target heater resistance

5.3.3.3 Gas Sensor wait time - *gas\_wait\_x*

Referring to Figure 1, the time between the beginning of the heat phase and the start of gas sensor resistance conversion depends on *gas\_wait\_x* setting as mentioned below.

Heater set-point	Register name	Address	Content	Description
0...9	<i>gas_wait_x</i> x is from 0 to 9	0x64...0x6D	<i>gas_wait_x</i> <5:0> x is from 0 to 9	64 timer values with 1 ms step sizes, all zeros means no wait
0...9	<i>gas_wait_x</i> x is from 0 to 9	0x64...0x6D	<i>gas_wait_x</i> <7:6> x is from 0 to 9	Please refer to the table below for settings

<i>gas_wait_x</i> <7:6>	Gas sensor wait time multiplication factor
00	1
01	4
10	16
11	64

5.3.3.4 Heater off - *heat\_off*

Register Name	Address	Content<bit position>	Description
<i>ctrl_gas_0</i>	0x70	<i>heat_off</i> <3>	Turn off current injected to heater by setting bit to one

### 5.3.3.5 Heater profile selection - *nb\_conv*

*nb\_conv* is used to select heater set-points of the sensor. The different heater set-points are described in the sections above.

Register Name	Address	Content<bit position>	Description
ctrl_gas_1	0x71	nb_conv<3:0>	Indicates index of heater set point that will be used in forced mode as describe in below table

nb_conv<3:0>	Heater profile set-point
0000	0
0001	1
0010	2
0011	3
0100	4
0101	5
0110	6
0111	7
1000	8
1001	9

### 5.3.3.6 Run Gas - *run\_gas*

Register Name	Address	Content<bit position>	Description
ctrl_gas_1	0x71	run_gas<4>	The gas conversions are started only in appropriate mode if run_gas = '1'

### 5.3.4 Data registers

In this section, the data registers for the temperature, pressure, humidity and gas sensors are explained. Shadowing registers are utilized to buffer the data and to ensure stable data in case an update of the data registers occurs simultaneously with the serial interface reading out.

#### 5.3.4.1 Pressure data

Register Name	Address	Content<bit position>	Description
press_msb	0x1F	press_msb<7:0>	Contains the MSB part [19:12] of the raw pressure measurement output data.
press_lsb	0x20	press_lsb<7:0>	Contains the LSB part [11:4] of the raw pressure measurement output data
press_xlsb	0x21	press_xlsb<7:4>	Contains the XLSB part [3:0] of the raw pressure measurement output data. Contents depend on pressure resolution controlled by oversampling setting.

#### 5.3.4.2 Temp data

Register Name	Address	Content<bit position>	Description
temp_msb	0x22	temp_msb<7:0>	Contains the MSB part [19:12] of the raw temperature measurement output data.
temp_lsb	0x23	temp_lsb<7:0>	Contains the LSB part [11:4] of the raw temperature measurement output data.
temp_xlsb	0x24	temp_xlsb<7:4>	Contains the XLSB part [3:0] of the raw temperature measurement output data. Contents depend on temperature resolution controlled by oversampling setting.

#### 5.3.4.3 Humidity data

Register Name	Address	Content<bit position>	Description
hum_msb	0x25	hum_msb<7:0>	Contains the MSB part [15:8] of the raw humidity measurement output data.
hum_lsb	0x26	hum_lsb<7:0>	Contains the LSB part [7:0] of the raw humidity measurement output data.

#### 5.3.4.4 Gas resistance data

Register Name	Address	Content<bit position>	Description
gas_r_msb	0x2A	gas_r<7:0>	Contains the MSB part gas resistance [9:2] of the raw gas resistance.
gas_r_lsb	0x2B	gas_r<7:6>	Contains the LSB part gas resistance [1:0] of the raw gas resistance.

#### 5.3.4.5 Gas resistance range

Register Name	Address	Content<bit position>	Description
gas_r_lsb	0x2B	gas_range_r<3:0>	Contains ADC range of measured gas resistance.

## 5.3.5 Status registers

### 5.3.5.1 New data status

The measured data are stored into the output data registers at the end of each TPHG conversion phase along with status flags and index of measurement.

Register Name	Address	Content<bit position>	Description
meas_status_0	0x1D	new_data_0<7>	New data flag

### 5.3.5.2 Gas measuring status

Measuring bit is set to “1” only during gas measurements, goes to “0” as soon as measurement is completed and data transferred to data registers. The registers storing the configuration values for the measurement (*gas\_wait\_shared*, *gas\_wait\_x*, *res\_heat\_x*, *idac\_heat\_x*, image registers) should not be changed when the device is measuring.

Register Name	Address	Content<bit position>	Description
meas_status_0	0x1D	gas_measuring<6>	Gas measuring status flag

### 5.3.5.3 Measuring status

Measuring status will be set to ‘1’ whenever a conversion (temperature, pressure, humidity and gas) is running and back to ‘0’ when the results have been transferred to the data registers.

Register Name	Address	Content<bit position>	Description
meas_status_0	0x1D	measuring<5>	Measuring status flag

### 5.3.5.4 Gas Measurement Index

User can program a sequence of up to 10 conversions by setting *nb\_conv*<3:0>. Each conversion has its own heater resistance target but 3 field registers to store conversion results. The actual gas conversion number in the measurement sequence (up to 10 conversions numbered from 0 to 9) is stored in *gas\_meas\_index* register.

Register Name	Address	Content<bit position>	Description
meas_status_0	0x1D	gas_meas_index_0<3:0>	Gas measurement index

#### 5.3.5.5 Gas valid status

In each TPHG sequence contains a gas measurement slot, either a real one which result is used or a dummy one to keep a constant sampling rate and predictable device timing. A real gas conversion (i.e., not a dummy one) is indicated by the *gas\_valid\_r* status register.

Register Name	Address	Content<bit position>	Description
gas_r_lsb	0x2B	gas_valid_r<5>	Gas valid bit

#### 5.3.5.6 Heater Stability Status

Heater temperature stability for target heater resistance is indicated *heat\_stab\_x* status bits.

Register Name	Address	Content<bit position>	Description
gas_r_lsb	0x2B	heat_stab_r<4>	Heater stability bit

## 6. Digital interfaces

The sensor supports the I<sup>2</sup>C and SPI digital interfaces, where it acts as a slave for both protocols. The I<sup>2</sup>C interface supports the Standard, Fast and High Speed modes. The SPI interface supports both SPI mode '00' (CPOL = CPHA = '0') and mode '11' (CPOL = CPHA = '1') in 4-wire and 3-wire configuration.

The following transactions are supported:

- Single byte write
- multiple byte write (using pairs of register addresses and register data)
- single byte read
- multiple byte read (using a single register address which is auto-incremented)

### 6.1 Interface selection

Interface selection is done automatically based on CSB (chip select) status. If CSB is connected to V<sub>DDIO</sub>, the I<sup>2</sup>C interface is active. If CSB is pulled down, the SPI interface is activated. After CSB has been pulled down once (regardless of whether any clock cycle occurred), the I<sup>2</sup>C interface is disabled until the next power-on-reset. This is done in order to avoid inadvertently decoding SPI traffic to another slave as I<sup>2</sup>C data. Since the device startup is deferred until both V<sub>DD</sub> and V<sub>DDIO</sub> are established, there is no risk of incorrect protocol detection because of the power-up sequence used. However, if I<sup>2</sup>C is to be used and CSB is not directly connected to V<sub>DDIO</sub> but is instead connected to a programmable pin, it must be ensured that this pin already outputs the V<sub>DDIO</sub> level during power-on-reset of the device. If this is not the case, the device will be locked in SPI mode and not respond to I<sup>2</sup>C commands.

### 6.2 I<sup>2</sup>C Interface

For detailed timings, please review Table 22 . All modes (standard, fast, high speed) are supported. SDA and SCL are not pure open-drain. Both pads contain ESD protection diodes to V<sub>DDIO</sub> and GND. As the device does not perform clock stretching, the SCL structure is a high-Z input without drain capability.

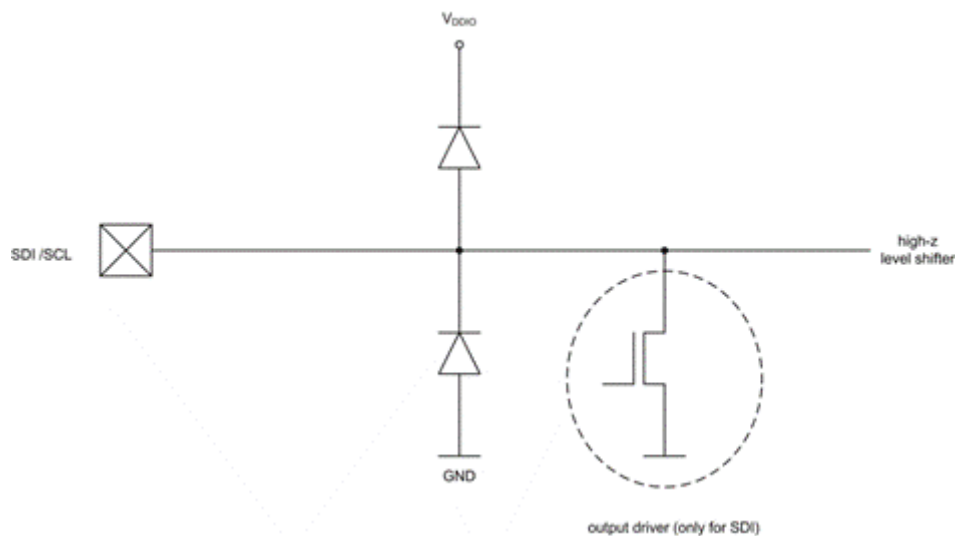

Picture 3: SDI/SCK ESD schematic

The 7-bit device address is 111011x. The 6 MSB bits are fixed. The last bit is changeable by SDO value and can be changed during operation. Connecting SDO to GND results in slave address 1110110 (0x76); connection it to V<sub>DDIO</sub> results in slave address 1110111 (0x77), which is the same as BMP280's I<sup>2</sup>C address. The SDO pin cannot be left floating; if left floating, the I<sup>2</sup>C address will be undefined.

The I<sup>2</sup>C interface uses the following pins:

- SCK: serial clock (SCL)
- SDI: data (SDA)
- SDO: Slave address LSB (GND = '0', V<sub>DDIO</sub> = '1')

CSB must be connected to V<sub>DDIO</sub> to select I<sup>2</sup>C interface. SDI is bi-directional with open drain to GND: it must be externally connected to V<sub>DDIO</sub> via a pull up resistor. Refer to Chapter 7 for connection instructions.

The following abbreviations will be used in the I<sup>2</sup>C protocol figures:

- S Start
- P Stop
- ACKS Acknowledge by slave
- ACKM Acknowledge by master
- NACKM Not acknowledge by master

### 6.2.1 I<sup>2</sup>C write

Writing is done by sending the slave address in write mode (RW = '0'), resulting in slave address 111011X0 ('X' is determined by state of SDO pin). Then the master sends pairs of register addresses and register data. The transaction is ended by a stop condition. This is depicted in Picture 4.

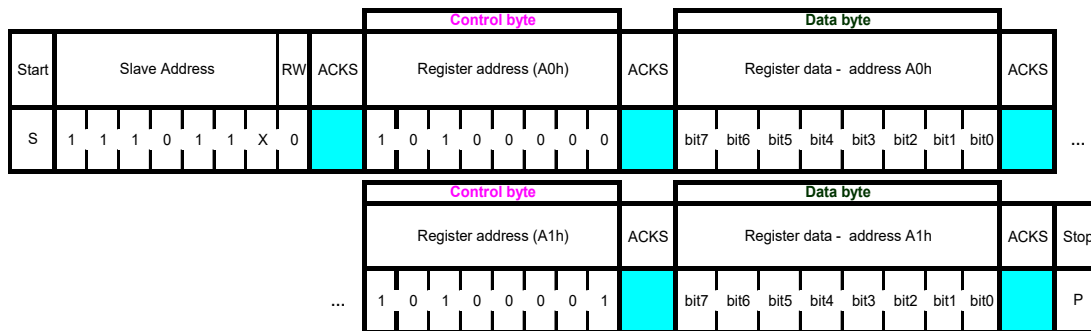

Picture 4: I<sup>2</sup>C multiple byte write (not auto-incremented)

### 6.2.2 I<sup>2</sup>C read

To be able to read registers, first the register address must be sent in write mode (slave address 111011X0). Then either a stop or a repeated start condition must be generated. After this the slave is addressed in read mode (RW = '1') at address 111011X1, after which the slave sends out data from auto-incremented register addresses until a NOACKM and stop condition occurs. This is depicted in Picture 5, where register 0xF6 and 0xF7 are read.

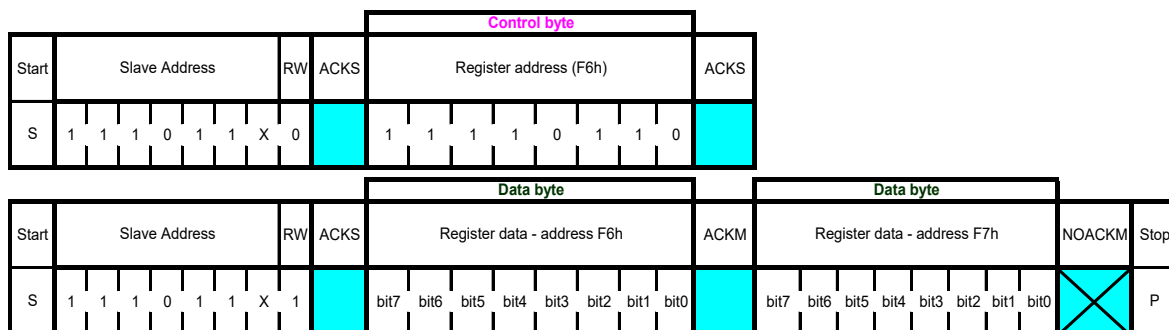

Picture 5: I<sup>2</sup>C multiple byte read

### 6.3 SPI interface

The SPI interface is compatible with SPI mode '00' (CPOL = CPHA = '0') and mode '11' (CPOL = CPHA = '1'). The automatic selection between mode '00' and '11' is determined by the value of SCK after the CSB falling edge.

The SPI interface has two modes, namely 4-wire and 3-wire mode. However, the protocol is the same for both. The 3-wire mode is selected by setting '1' to the register spi3w\_en. The pad SDI is used as a data pad in 3-wire mode.

The SPI interface uses the following pins:

- CSB: chip select, active low
- SCK: serial clock
- SDI: serial data input; data input/output in 3-wire mode
- SDO: serial data output; hi-Z in 3-wire mode

For more connection instructions, please refer to Chapter 7.

CSB is active low and has an integrated pull-up resistor. Data on SDI is latched by the device at SCK rising edge and SDO is changed at SCK falling edge. Communication starts when CSB goes to low and stops when CSB goes to high; during these transitions on CSB, SCK must be stable. The SPI protocol is shown in It is important to note that Picture 6. For timing details, please review Table 23.

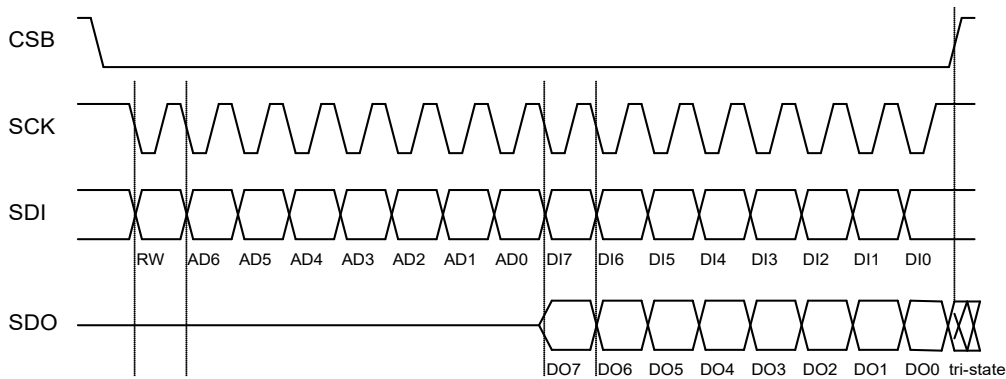

Picture 6: SPI protocol (shown for mode '11' in 4-wire configuration)

It is important to note that in the SPI mode, only 7 bits of the register addresses are used; the MSB of register address is not used and replaced by a read/write bit (RW = '0' for write and RW = '1' for read). For example, address 0xF7 is accessed by using SPI register address 0x77. On the one hand, the byte 0x77 is transferred for write access, and on the other hand, the byte 0xF7 is transferred for read access.

#### 6.3.1 SPI write

Writing is done by lowering CSB and sending pairs control bytes and register data. The control bytes consist of the SPI register address (= full register address without bit 7) and the write command (bit7 = RW = '0'). Several pairs can be written without raising CSB. The transaction is ended by a raising CSB. The SPI write protocol is depicted in Picture 7.

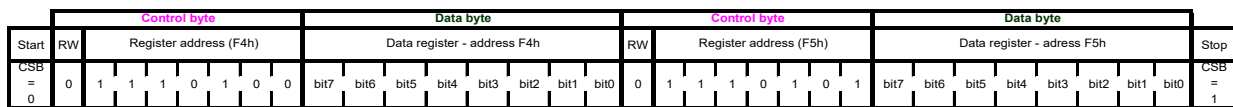

Picture 7: SPI multiple byte write (not auto-incremented)

### 6.3.2 SPI read

Reading is done by lowering CSB and first sending one control byte. The control bytes consist of the SPI register address (= full register address without bit 7) and the read command (bit 7 = RW = '1'). After writing the control byte, data is sent out of the SDO pin (SDI in 3-wire mode); the register address is automatically incremented. The SPI read protocol is depicted in Picture 8.

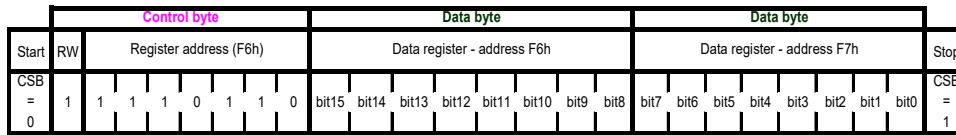

Picture 8: SPI multiple byte read

## 6.4 Interface parameter specification

### 6.4.1 General interface parameters

Table 21: Interface parameters

Parameter	Symbol	Condition	Min	Typ	Max	Unit
Input low level	V <sub>il_si</sub>	V <sub>DDIO</sub> =1.2 V to 3.6 V			20	%V <sub>DDIO</sub>
Input high level	V <sub>ih_si</sub>	V <sub>DDIO</sub> =1.2 V to 3.6 V	80			%V <sub>DDIO</sub>
Output low level I <sup>2</sup> C	V <sub>ol_SDI</sub>	V <sub>DDIO</sub> =1.62 V, I <sub>ol</sub> =3 mA			20	%V <sub>DDIO</sub>
Output low level I <sup>2</sup> C	V <sub>ol_SDI_1.2</sub>	V <sub>DDIO</sub> =1.20 V, I <sub>ol</sub> =3 mA			23	%V <sub>DDIO</sub>
Output low level SPI	V <sub>ol_SDO</sub>	V <sub>DDIO</sub> =1.62 V, I <sub>ol</sub> =1 mA			20	%V <sub>DDIO</sub>
Output low level SPI	V <sub>ol_SDO_1.2</sub>	V <sub>DDIO</sub> =1.20 V, I <sub>ol</sub> =1 mA			23	%V <sub>DDIO</sub>
Output high level	V <sub>oh</sub>	V <sub>DDIO</sub> =1.62 V, I <sub>oh</sub> =1 mA (SDO, SDI)	80			%V <sub>DDIO</sub>
Output high level	V <sub>oh_1.2</sub>	V <sub>DDIO</sub> =1.20 V, I <sub>oh</sub> =1 mA (SDO, SDI)	60			%V <sub>DDIO</sub>
Pull-up resistor	R <sub>pull</sub>	Internal CSB pull-up resistor to V <sub>DDIO</sub>	70	120	190	kΩ
I <sup>2</sup> C bus load capacitor	C <sub>b</sub>	On SDI and SCK			400	pF

### 6.4.2 I<sup>2</sup>C timings

For I<sup>2</sup>C timings, the following abbreviations are used:

- “S&F mode” = standard and fast mode
- “HS mode” = high speed mode
- C<sub>b</sub> = bus capacitance on SDA line

All other naming refers to I<sup>2</sup>C specification 2.1 (January 2000).

The I<sup>2</sup>C timing diagram is in Picture 9. The corresponding values are given in Table 22

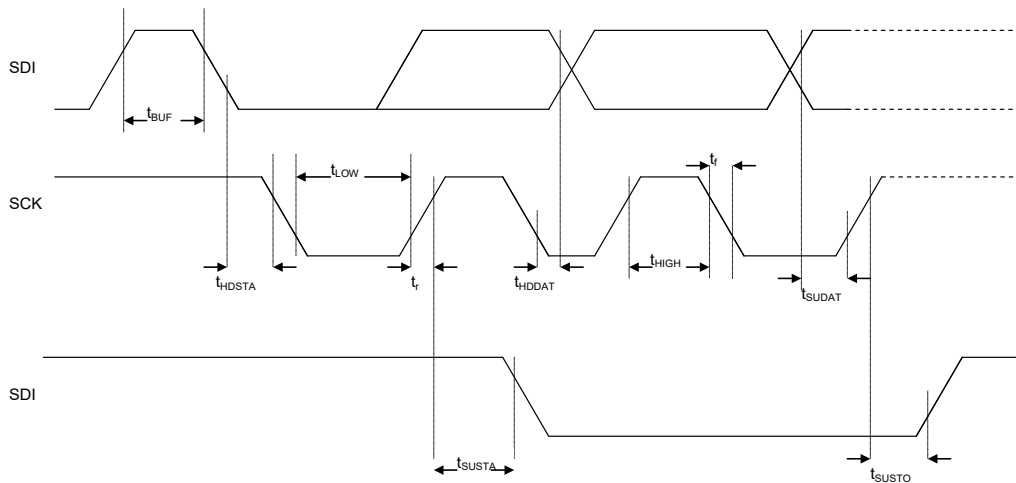

Picture 9: I<sup>2</sup>C timing diagram

Table 22: I<sup>2</sup>C timings

Parameter	Symbol	Condition	Min	Typ	Max	Unit
SDI setup time	t <sub>SU;DAT</sub>	S&F Mode	160			ns
		HS mode	30			ns
SDI hold time	t <sub>HD;DAT</sub>	S&F Mode, C <sub>b</sub> ≤100 pF	80			ns
		S&F Mode, C <sub>b</sub> ≤400 pF	90			ns
		HS mode, C <sub>b</sub> ≤100 pF	18		115	ns
		HS mode, C <sub>b</sub> ≤400 pF	24		150	ns
SCK low pulse	t <sub>LOW</sub>	HS mode, C <sub>b</sub> ≤100 pF V <sub>DDIO</sub> = 1.62 V	160			ns
SCK low pulse	t <sub>LOW</sub>	HS mode, C <sub>b</sub> ≤100 pF V <sub>DDIO</sub> = 1.2 V	210			ns

The above-mentioned I<sup>2</sup>C specific timings correspond to the following internal added delays:

- Input delay between SDI and SCK inputs: SDI is more delayed than SCK by typically 100 ns in Standard and Fast Modes and by typically 20 ns in High Speed Mode.
- Output delay from SCK falling edge to SDI output propagation is typically 140 ns in Standard and Fast Modes and typically 70 ns in High Speed Mode.

### 6.4.3 SPI timings

The SPI timing diagram is in Picture 10, while the corresponding values are given in Table 23. All timings apply both to 4- and 3-wire SPI.

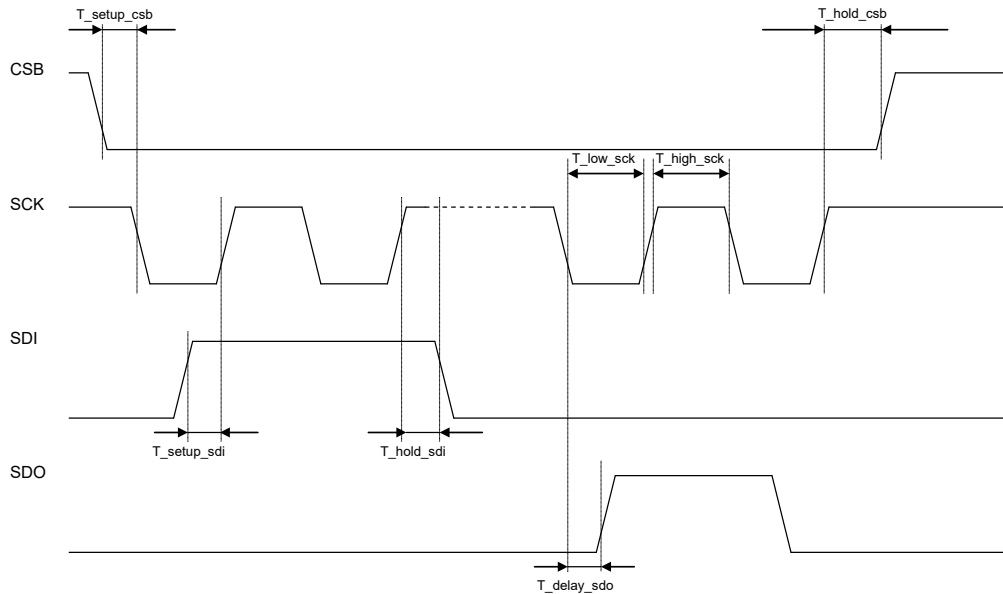

Picture 10: SPI timing diagram

Table 23: SPI timings

Parameter	Symbol	Condition	Min	Typ	Max	Unit
SPI clock i/p frequency	$F_{\text{spi}}$		0		10	MHz
SCK low pulse	$T_{\text{low\_sck}}$		20			ns
SCK high pulse	$T_{\text{high\_sck}}$		20			ns
SDI setup time	$T_{\text{setup\_sdi}}$		20			ns
SDI hold time	$T_{\text{hold\_sdi}}$		20			ns
SDO output delay	$T_{\text{delay\_sdo}}$	25 pF load, $V_{\text{DDIO}}=1.6 \text{ V min}$			30	ns
SDO output delay	$T_{\text{delay\_sdo}}$	25 pF load, $V_{\text{DDIO}}=1.2 \text{ V min}$			40	ns
CSB setup time	$T_{\text{setup\_csb}}$		20			ns
CSB hold time	$T_{\text{hold\_csb}}$		20			ns
SPI clock input frequency	$F_{\text{spi}}$		0		10	MHz

## 7. Pin-out and connection diagram

### 7.1 Pin-out

The pin numbering of BME680 is performed in the untypical clockwise direction when seen in top view and counter-clockwise when seen in bottom view. Picture 11 and Table 24 give a detailed description and illustration of the input/output pins.

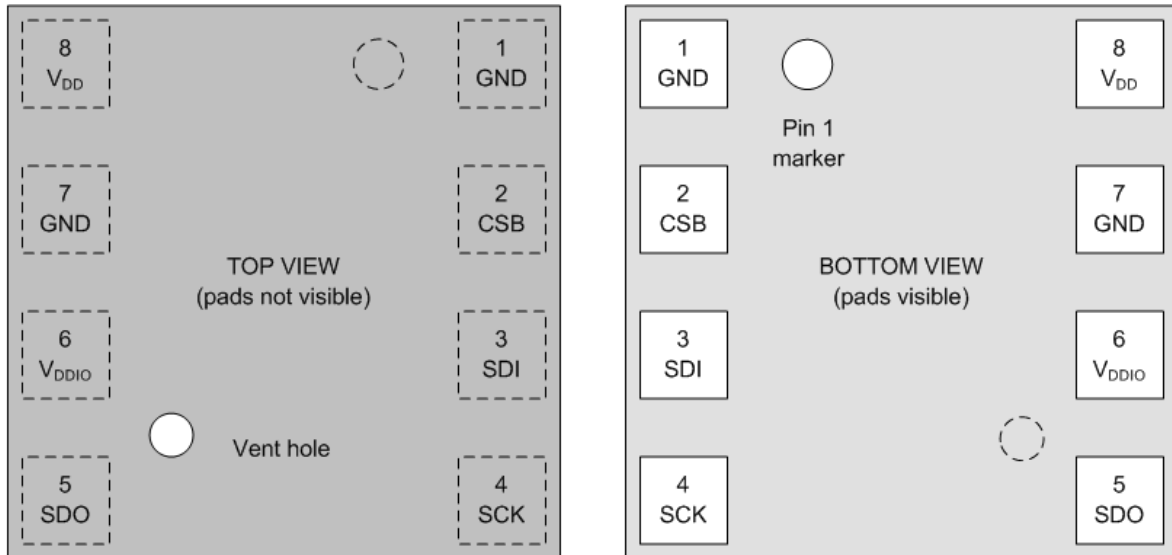

Picture 11: Top (left) and bottom (right) views of the chip with input/output pins

Table 24: Pin description

Pin	Name	I/O type	Description	Connection		
				SPI 4W	SPI 3W	I <sup>2</sup> C
1	GND	Supply	Ground	GND		
2	CSB	In	Chip select	CSB	CSB	V <sub>DDIO</sub>
3	SDI	In/Out	Serial data input	SDI	SDI/SDO	SDA
4	SCK	In	Serial clock input	SCK	SCK	SCL
5	SDO	In/Out	Serial data output	SDO	DNC	GND for default address
6	V <sub>DDIO</sub>	Supply	Digital / Interface supply	V <sub>DDIO</sub>		
7	GND	Supply	Ground	GND		
8	V <sub>DD</sub>	Supply	Analog supply	V <sub>DD</sub>		

## 7.2 Connection diagrams

For the I<sup>2</sup>C connection, it is recommended to use 100 nF for C<sub>1</sub> and C<sub>2</sub>. Moreover, the value for the pull-up resistors R<sub>1</sub> and R<sub>2</sub> should be based on the interface timing and the bus load; a normal value is 4.7 kΩ. Finally, a direct connection between CSB and V<sub>DDIO</sub> is required. Similarly for the 4- and 3-wire SPI connections, it is suggested to use 100 nF for C<sub>1</sub> and C<sub>2</sub>.

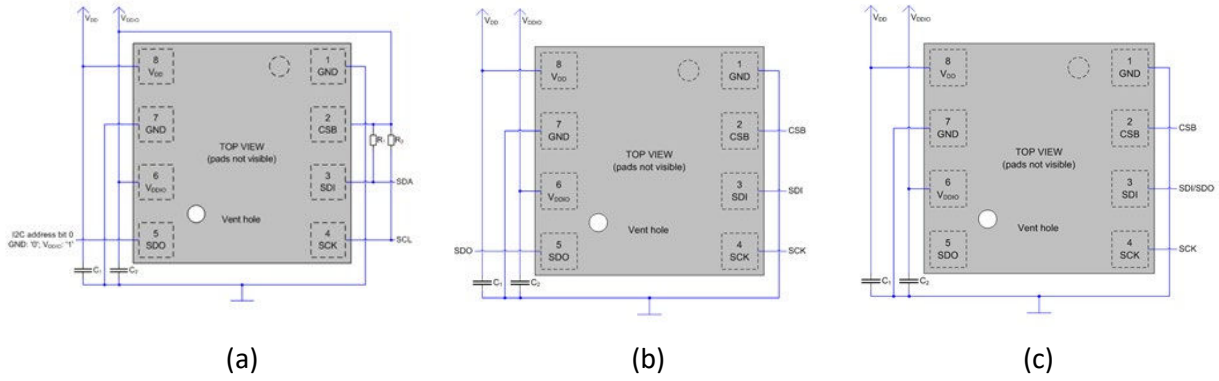

Picture 12: Connection diagrams for (a) I<sup>2</sup>C, (b) 4-wire SPI, and (c) 3-wire SPI

### 7.3 Package dimensions

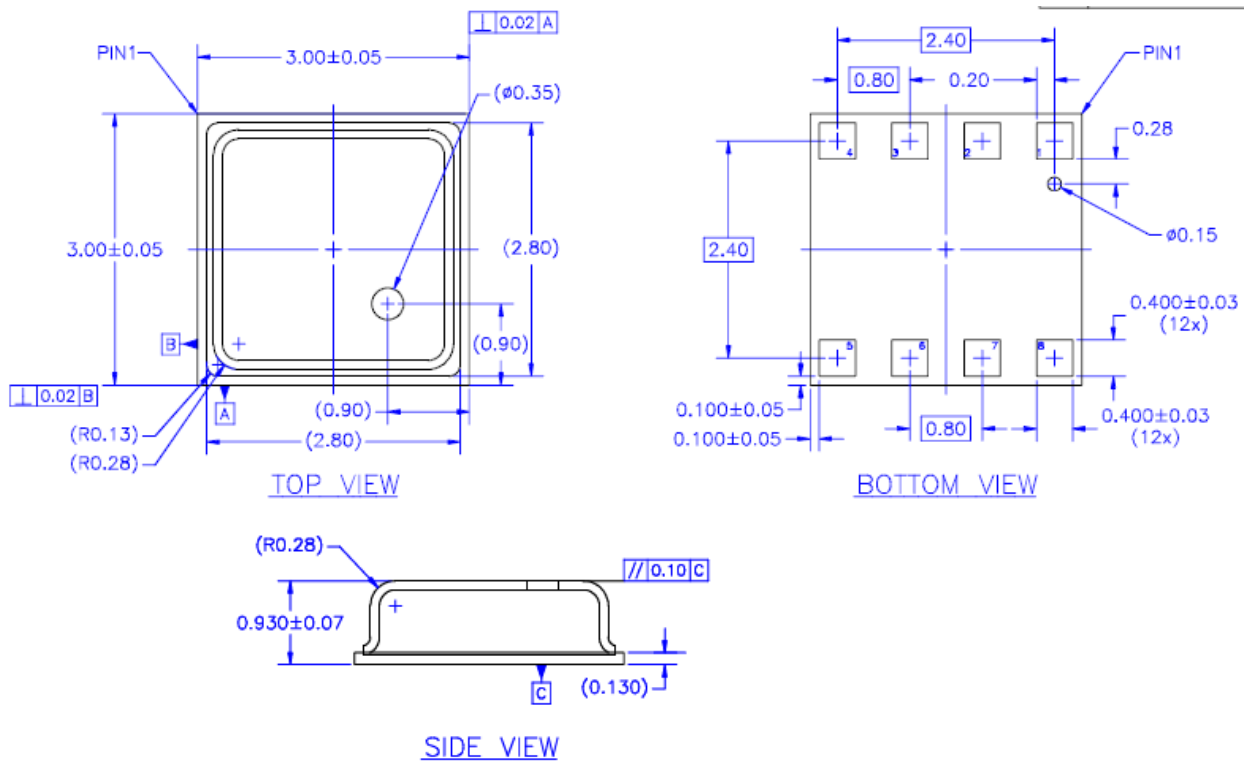

2. REFERENCE SPECIFICATIONS:
  - A. AWW SPEC #001-0531-2234: PACKING OPERATION PROCEDURE.
  - B. AWW SPEC #001-0519-2062: MARKING.

1. ALL DIMENSIONS AND TOLERANCES CONFORM TO ANSI Y14.5M-1994.

NOTES: UNLESS OTHERWISE SPECIFIED

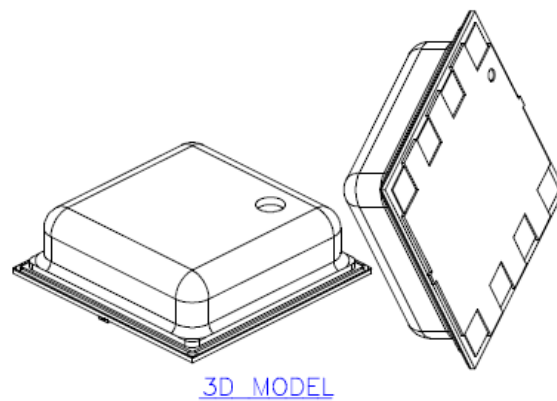

Picture 13: Package dimensions for top, bottom and side view

## 7.4 Landing pattern recommendation

For the design of the landing pattern, the dimensions shown in Picture 14: Recommended landing pattern (top view; dimensions are in milli-meters) are recommended. It is important to note that areas marked in red are exposed PCB metal pads.

- In case of a solder mask defined (SMD) PCB process, the land dimensions should be defined by solder mask openings. The underlying metal pads are larger than these openings.
- In case of a non-solder mask defined (NSMD) PCB process, the land dimensions should be defined in the metal layer. The mask openings are larger than these metal pads.

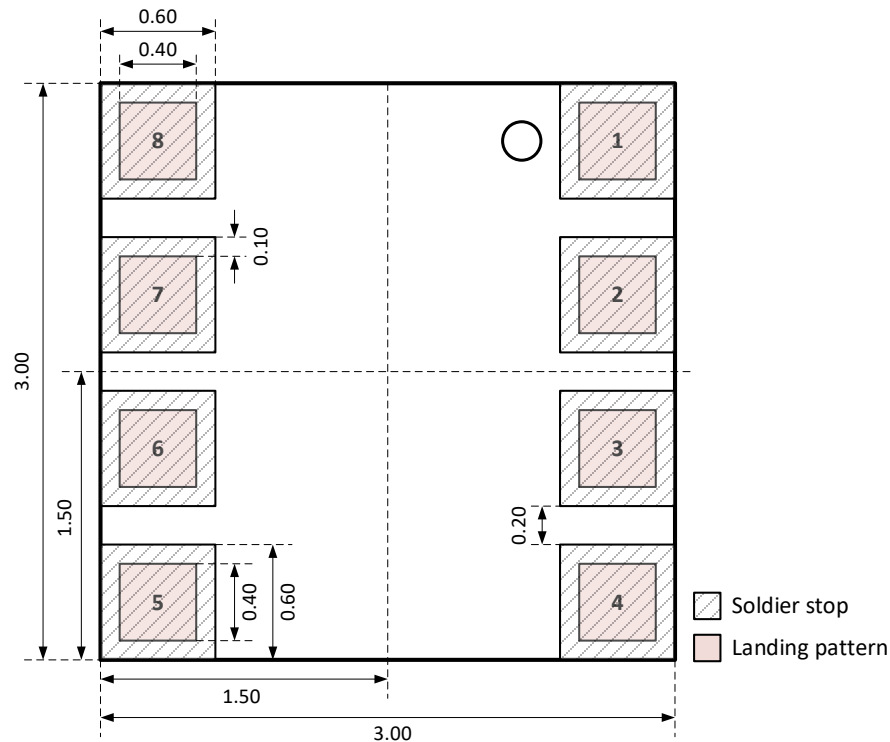

Picture 14: Recommended landing pattern (top view; dimensions are in milli-meters)

## 7.5 Marking

### 7.5.1 Mass production devices

Table 25: Marking of mass production parts

Marking	Symbol	Description
	CCC	<u>Lot counter</u> : 3 alphanumeric digits, variable to generate mass production trace-code
	T	<u>Product number</u> : 1 alphanumeric digit, fixed to identify product type, T = "S" or "E" "S" is associated with the product BME680 (part number 0 273 141 229) "E" is associated with the product BME680 (part number 0 273 141 312)
	L	<u>Sub-contractor ID</u> : 1 alphanumeric digit, variable to identify sub-contractor (L = "P")

### 7.5.2 Engineering samples

Table 26: Marking of engineering samples

Marking	Symbol	Description
	XX	Sample ID: 2 alphanumeric digits, variable to generate trace-code
	N	Eng. Sample ID: 1 alphanumeric digit, fixed to identify engineering sample, N = "*" or "e" or "E"
	CC	Counter ID: 2 alphanumeric digits, variable to generate trace-code

### 7.6 Soldering guidelines and reconditioning recommendations

The moisture sensitivity level of the BME680 sensors corresponds to JEDEC Level 1, see also:

- IPC/JEDEC J-STD-020C “Joint Industry Standard: Moisture/Reflow Sensitivity Classification for non-hermetic Solid State Surface Mount Devices”
- IPC/JEDEC J-STD-033A “Joint Industry Standard: Handling, Packing, Shipping and Use of Moisture/Reflow Sensitive Surface Mount Devices”

The sensor fulfils the lead-free soldering requirements of the above-mentioned IPC/JEDEC standard, i.e. reflow soldering with a peak temperature up to 260°C. The minimum height of the solder after reflow shall be at least 50 µm. This is required for good mechanical decoupling between the sensor device and the printed circuit board (PCB).

Profile Feature		Pb-Free Assembly
Average Ramp-Up Rate (Ts <sub>max</sub> to Tp)		3° C/second max.
<b>Preheat</b> – Temperature Min (Ts <sub>min</sub> ) – Temperature Max (Ts <sub>max</sub> ) – Time (ts <sub>min</sub> to ts <sub>max</sub> )		150 °C 200 °C 60-180 seconds
Time maintained above: – Temperature (T <sub>L</sub> ) – Time (t <sub>L</sub> )		217 °C 60-150 seconds
Peak/Classification Temperature (Tp)		260 °C
Time within 5 °C of actual Peak Temperature (tp)		20-40 seconds
Ramp-Down Rate		6 °C/second max.
Time 25 °C to Peak Temperature		8 minutes max.

Note 1: All temperatures refer to top side of the package, measured on the package body surface.

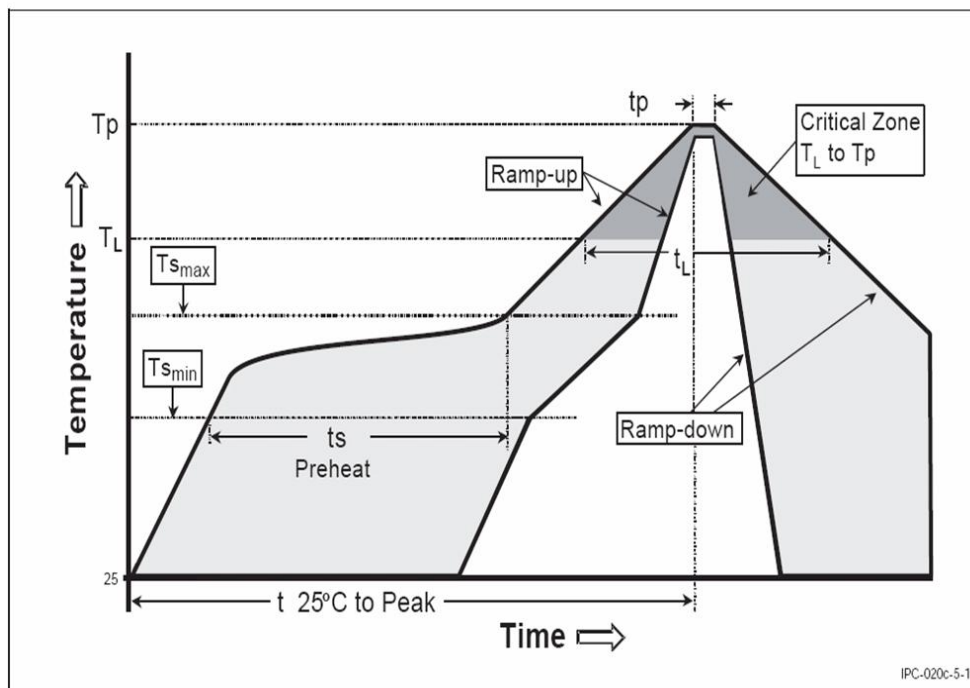

Picture 15: Soldering profile

### 7.7 Mounting and assembly recommendations

This HSMI-document provides all the necessary instructions to handle, solder and mount the environmental sensor BME680. Following the reported guidelines is very important to prevent the damage of the sensor and the resultant loss of warranty.

## 7.8 Environmental safety

### 7.8.1 RoHS

The BME680 sensor meets the requirements of the EC restriction of hazardous substances (RoHS) directive, see also: *Directive 2011/65/EU of the European Parliament and of the Council of 8 June 2011 on the restriction of the use of certain hazardous substances in electrical and electronic equipment.*

### 7.8.2 Halogen content

The BME680 is halogen-free. For more details on the analysis results please contact your Bosch Sensortec representative.

### 7.8.3 Internal package structure

Within the scope of Bosch Sensortec's ambition to improve its products and secure the mass product supply, Bosch Sensortec qualifies additional sources (e.g. 2<sup>nd</sup> source) for the packaging and processing of the BME680.

While Bosch Sensortec took care that all of the technical packages parameters are described above are 100% identical for all sources, there can be differences in the chemical content and the internal structural between the different package sources.

However, as secured by the extensive product qualification process of Bosch Sensortec, this has no impact to the usage or to the quality of the BME680 product.

## 8. Legal disclaimer

### 8.1 Engineering samples

Engineering Samples are marked with an asterisk (\*) or (e). Samples may vary from the valid technical specifications of the product series contained in this data sheet. They are therefore not intended or fit for resale to third parties or for use in end products. Their sole purpose is internal client testing. The testing of an engineering sample may in no way replace the testing of a product series. Bosch Sensortec assumes no liability for the use of engineering samples. The Purchaser shall indemnify Bosch Sensortec from all claims arising from the use of engineering samples.

### 8.2 Product use

Bosch Sensortec products are developed for the consumer goods industry. They may only be used within the parameters of this product data sheet. They are not fit for use in life-sustaining or safety-critical systems. Safety-critical systems are those for which a malfunction is expected to lead to bodily harm, death or severe property damage. In addition, they shall not be used directly or indirectly for military purposes (including but not limited to nuclear, chemical or biological proliferation of weapons or development of missile technology), nuclear power, deep sea or space applications (including but not limited to satellite technology).

The resale and/or use of Bosch Sensortec products are at the purchaser's own risk and his own responsibility. The examination of fitness for the intended use is the sole responsibility of the purchaser.

The purchaser shall indemnify Bosch Sensortec from all third party claims arising from any product use not covered by the parameters of this product data sheet or not approved by Bosch Sensortec and reimburse Bosch Sensortec for all costs in connection with such claims.

The purchaser accepts the responsibility to monitor the market for the purchased products, particularly with regard to product safety, and to inform Bosch Sensortec without delay of all safety-critical incidents.

### 8.3 Application examples and hints

With respect to any examples or hints given herein, any typical values stated herein and/or any information regarding the application of the device, Bosch Sensortec hereby disclaims any and all warranties and liabilities of any kind, including without limitation warranties of non-infringement of intellectual property rights or copyrights of any third party. The information given in this document shall in no event be regarded as a guarantee of conditions or characteristics. They are provided for illustrative purposes only and no evaluation regarding infringement of intellectual property rights or copyrights or regarding functionality, performance or error has been made.

## 9. Document history and modifications

Rev.	Chapter	Description of modifications	Date
1.0		Initial release	July 2017
1.1	5.2 7.5.1	Fixed typo Added new technical reference code	April 2019
1.2	1.2 3.3 4.1 5.3.1.4 5.2 8.	Added Hyperlinks to Table of contents Table 4 updated Added code examples & Tables 11-16 Added q-ULP to Table 17 Added new BSEC outputs to Table 18 Removed Ambient temperature, Ambient relative humidity Changed ranges of memory pages Changed status register from 01h to 00h New disclaimer	May 2019
1.3	1.4	Removed link to T and H compensation formula	July 2019



Bosch Sensortec GmbH  
Gerhard-Kindler-Straße 9  
72770 Reutlingen / Germany

[www.bosch-sensortec.com](http://www.bosch-sensortec.com)

Modifications reserved | Printed in Germany  
Preliminary - specifications subject to change without notice  
Document number: BST-BME680-DS001-03  
Revision\_1.3\_072019