

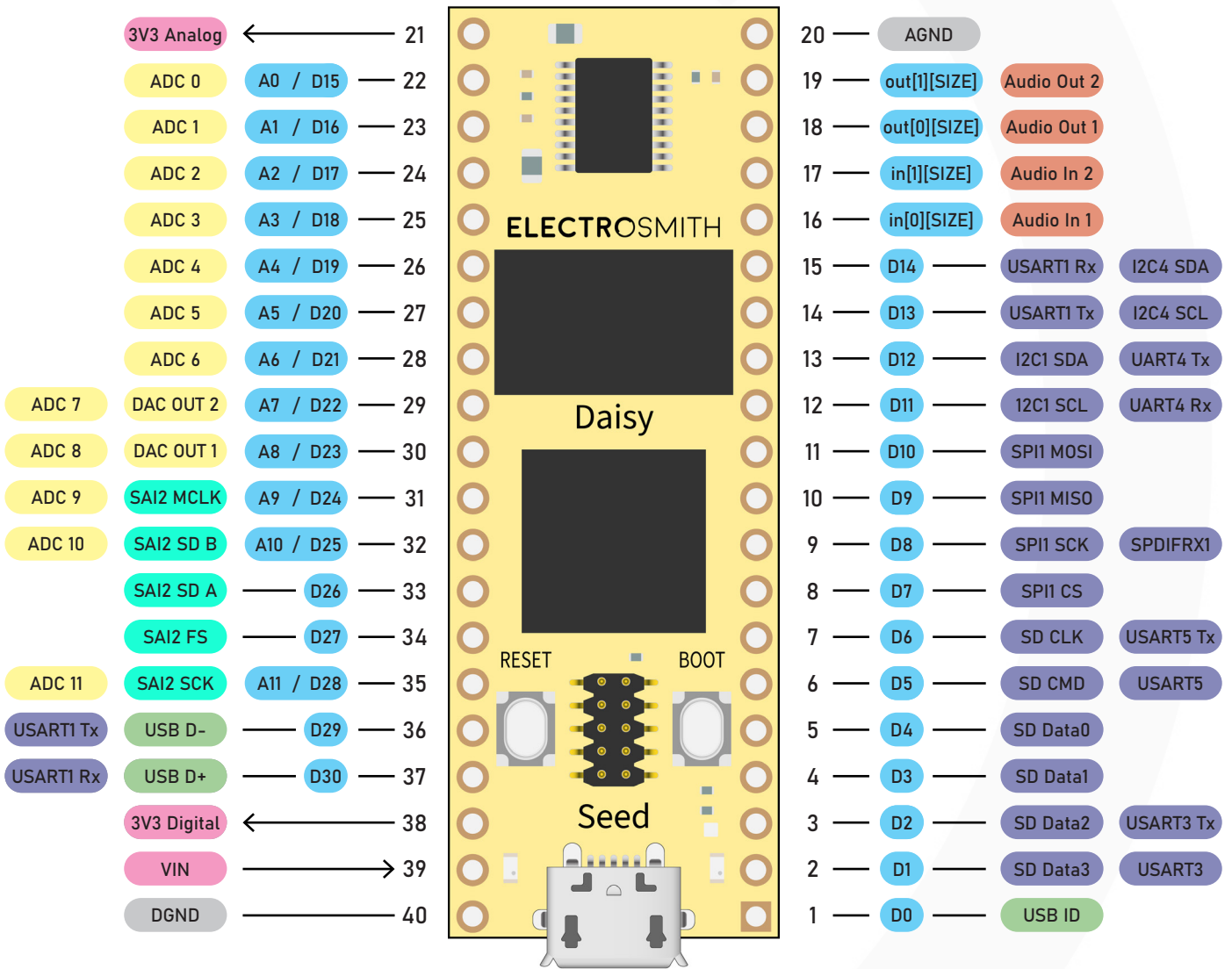

## Pinout



\* "D" for Digital GPIO or "A" for Analog I/O, depending on use case.