



ESSENTIAL INFORMATION

- BUILD INSTRUCTIONS
- CHECKING YOUR PCB & FAULT-FINDING
- MECHANICAL DETAILS
- HOW THE KIT WORKS

CONTROL YOUR EQUIPMENT WITH THIS

RELAY BOARD KIT

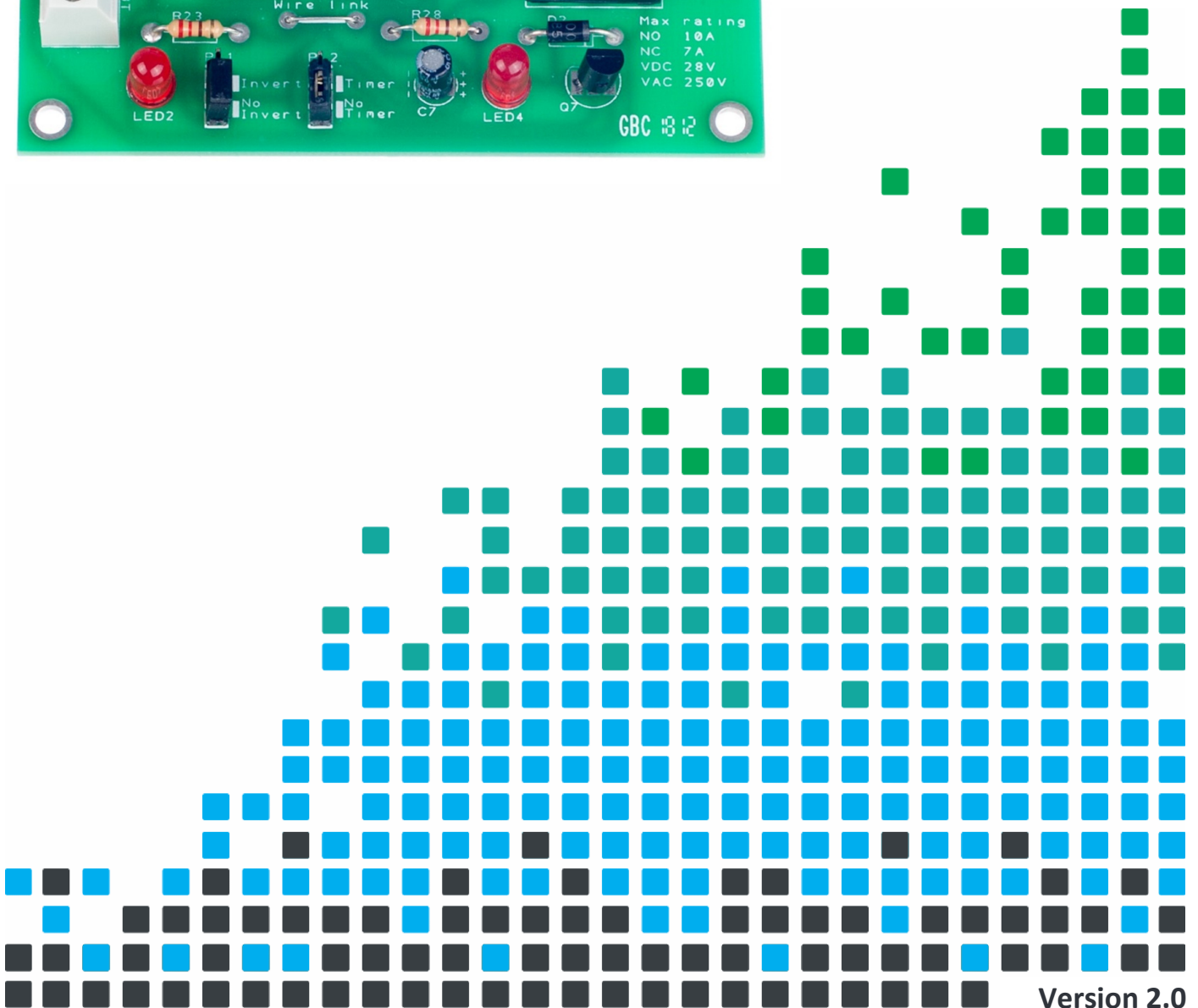
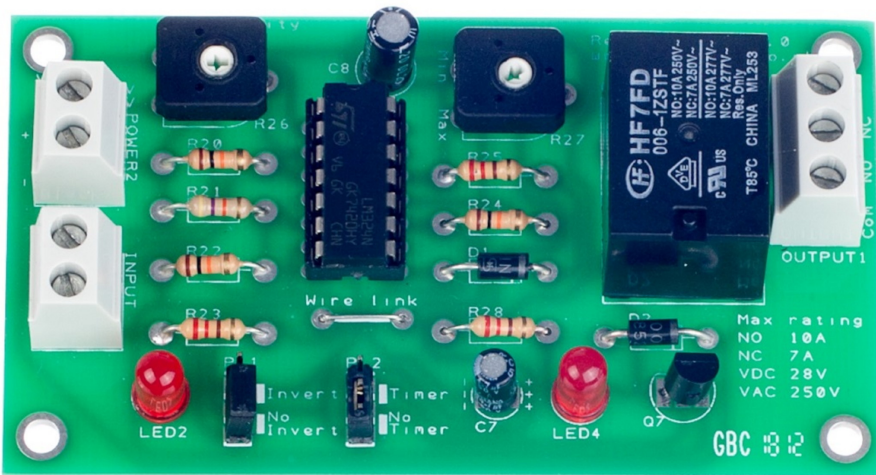

Features of the Relay board

Introduction

This is a versatile board that can easily be configured via jumpers and trimmer potentiometers to do a range of tasks.

Most sensor and switches can be connected to the input of the board and the trigger level set for the input device. This can be inverted if required, then there is the option to feed this straight to the relay or a timer of up to 25 minutes can be used.

Technical information

Operating voltage:	4.5V - 6.0V
Input type:	Switch / resistive sensor
Max sensor resistance:	100K Ω
Sensor threshold:	Set via trimmer
Input inversion:	Via jumper
Output delay on/ off:	Via jumper
Max delay length:	25 minutes
Delay accuracy:	$\pm 20\%$
Outputs:	NO / NC
Max output VDC:	28 V
Max output VAC:	250 V
Max out current NO:	10A
Max out current NC:	7A
Max propagation delay:	15mS
Max operating current:	90mA

Block diagram

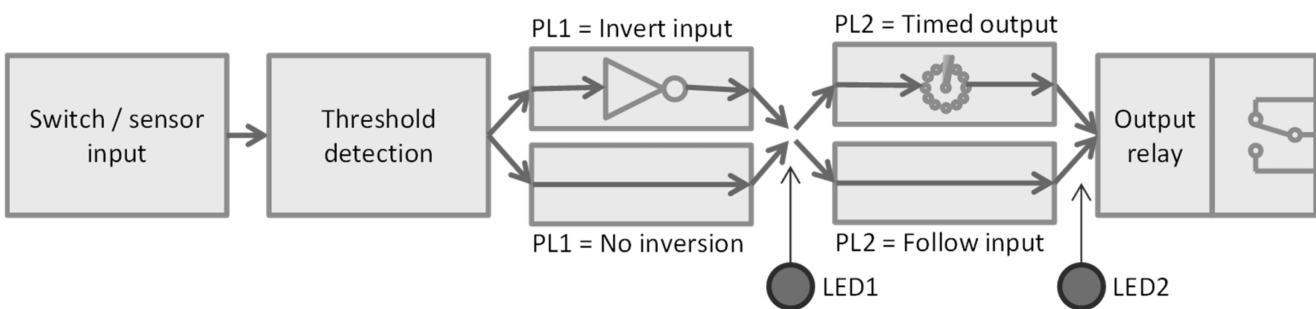

Relay board kit Essentials

www.kitronik.co.uk/2144



Using the relay board

This board is very easy to set-up. 5V should be connected to the power terminal block and a switch or sensor connected to the input terminal block. The sensitivity and duration of the delay are set by potentiometers R4 and R8 respectively. Whether the input is inverted and whether the output is on for a delayed period or follows the sensor state is determined by jumpers PL1 and PL2 respectively. The relay output has connections for the common signal (Com) as well as NO (Normally Open) and NC (Normally Closed).

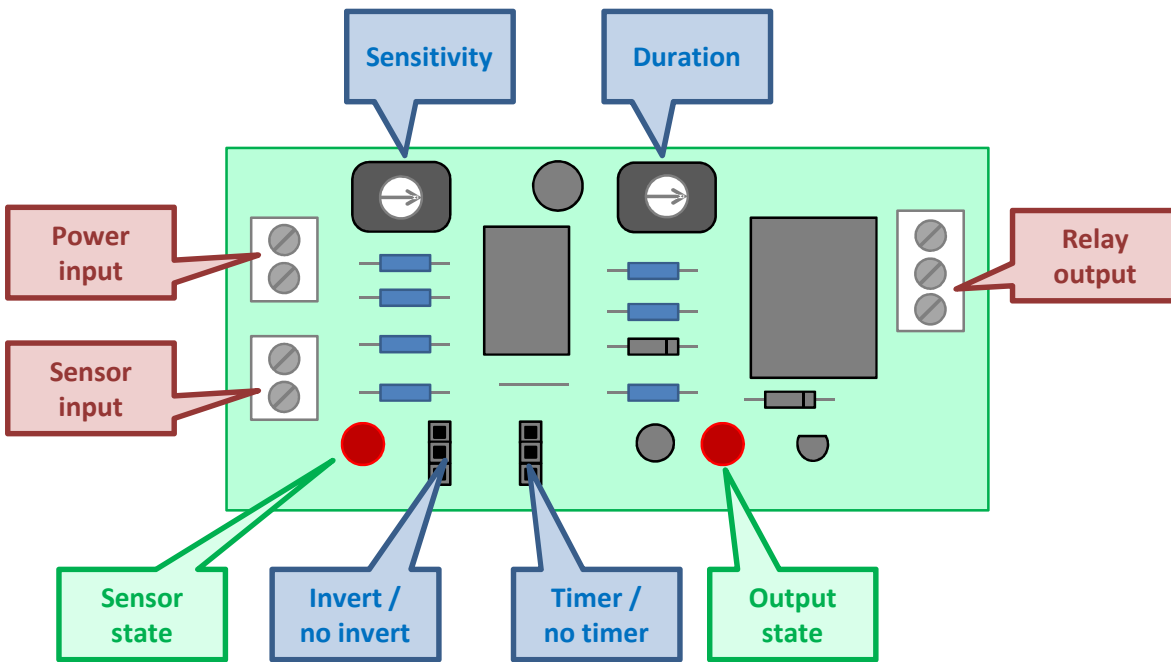

Mechanical information

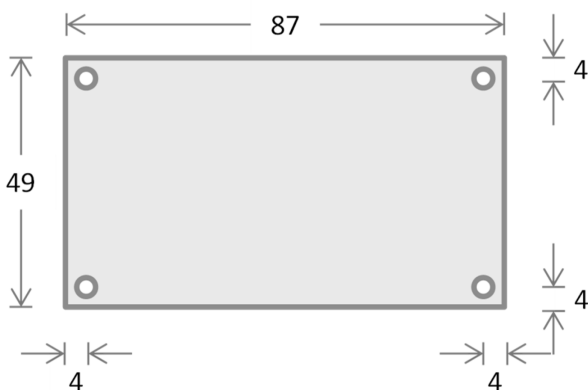

All dimensions in mm.

Max height of board & components is 18.5 mm.



Build Instructions

Before you start, take a look at the Printed Circuit Board (PCB). The components go in the side with the writing on and the solder goes on the side with the tracks and silver pads.

1 PLACE RESISTORS

Start with the 7 resistors:

The text on the PCB shows where R1, R2 etc go.

Ensure that you put the resistors in the right place.

PCB Ref	Value	Colour Bands
R1, R3 & R5	10k Ω	Brown, black, orange
R6, R7 & R9	220 Ω	Red, red, brown
R2	47k Ω	Yellow, purple, orange

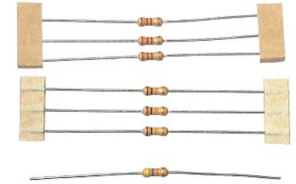

2 Place the diodes

Solder the two diodes into the board. When putting these into the board, be sure to get them the right way around. The band on the diode must match up with the band on the PCB. The diodes are marked D1 & D2.

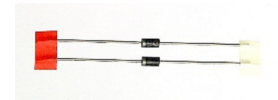

3 Place the wire link

A wire link needs to be added. Take a piece of wire (use a piece from a resistor you have just cut off) and solder it into the board where it is marked wire link.

4 Place the variable resistors

Solder the variable resistors into R4 & R8. They will only fit in the holes in the board when they are the correct way around. The two resistors are different values, R4 is a 1M and R8 is 10M, make sure you solder each in the right place.



5 Place the IC Holder

Solder the IC holder into IC1. When putting it into the board, be sure to get it the right way around. The notch on the IC holder should line up with the notch on the lines marked on the PCB.

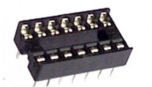

6 Place the Capacitors

Solder the two electrolytic capacitors into C1 & C2. These need to be put in the board the correct way around. The white band on capacitors should line up with the '-' markings on the board. The capacitors are different values, C1 is a 4.7 μ F and C2 is a 100 μ F.

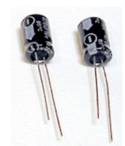

Build Instructions continued

7

Place the FET

Place the FET in to the board where it is labelled Q1. Make sure the device is the correct way around. The shape of the device should match the outline on the PCB.



8

Place the LED's

Solder the two Light Emitting Diodes (LEDs) in to LED1 & LED2. The LEDs won't work if they don't go in the correct way around. If you look carefully one side of the LED has a flat edge, which must line up with the flat edge on the lines on the PCB.



9

Place the terminal blocks

Solder the terminal blocks into the board. The two way terminal blocks are for the 'POWER' and the 'INPUT' connections and the three way terminal block is for the 'OUTPUT'. Make sure the side that the wire goes into is facing the edge of the board.



10

Place the pin headers

The kit is supplied with a 6 way section of pin header. This should be snapped into two sections with three pins. It can then be soldered into PL1 & PL2.

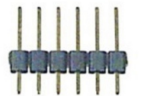

11

Place the relay

Solder the relay into Q2. There is only one way this will go into the board.



12

Place the IC Chip

Now put the LM324 quad op amp chip into the holder labelled IC1 ensuring the notch on the chip lines up with the notch on the holder.



Checking Your Relay Board PCB

Check the following:-

Check the bottom of the board to ensure that:

- All holes (except the 4 large 3 mm holes) are filled with the lead of a component.
- All these leads are soldered.
- Pins next to each other are not soldered together.

Check the top of the board to ensure that:

- The notch on the IC is next to C2.
- R1, R3 & R5 are 10k (Brown, Black, Orange, coloured bands).
- R6, R7 & R9 are 220R (Red, Red, Brown, coloured bands).
- The silver bands on diodes D1 and D2 are matching the markings on the board.
- The two LEDs are in the right way around (the flat edge on the LED matches the markings on the board).
- The white band on the two capacitors match the '---' markings on the board.
- A wire link is present next to the jumper PL2.

Parts list

Ref	Description	Qty
R1,R3 & R5	10K resistor 5%	3
R6,R7 & R9	220R resistor 5%	3
R2	47K resistor 5%	1
R4	1M Pot	1
R8	10M Pot	1
D1-D2	1N4001 diode, 1A	2
LED1 – LED2	LED red 5 mm	2
C2	100uF electrolytic capacitor	1
C1	4.7uF electrolytic capacitor	1
Q1	N Chanel FET (2N7000)	1
POWER, INPUT	2 way terminal block	2
OUTPUT	3 way terminal block	1
IC1	14 pin IC holder	1
IC1	LM324	1
Wire Link	Discarded resistor lead	1
Q2	Relay, HF7FD	1
PL1, PL2	3 way single row PCB header plug	2
PL1, PL2	Closed link jumper	2



Relay board kit Essentials

www.kitronik.co.uk/2144



Testing the PCB

To test the board:

- Place a jumper on PL1 to set No invert.
- Place a jumper on PL2 to set No timer.
- Connect a sensor or a switch to the 'INPUT' connection.
- Connect 5V (3x AA batteries or a power supply to the 'POWER' connection. Red to '+' and black to '-'.
- If necessary adjust the sensitivity trimmer potentiometer.

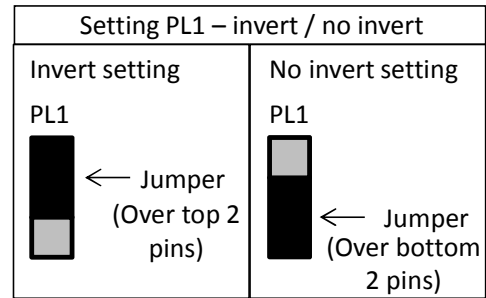

When the sensor is triggered both LEDs should change state and the relay should click.

- Now set PL1 to Invert.

The LEDs should be the opposite way around to before.

- Set PL2 to timer.
- Turn the duration trimmer fully anti-clockwise and then bring it back clockwise a fraction.

When LED1 turns on this time LED2 should go on for a short time.

If there is a problem with the board this can be diagnosed with the fault finding flow chart on the next page.

Example applications

PIR triggered sounder

Suppose you want to detect if someone has walked into a space and audibly sound this elsewhere. Then you could use a PIR module, the relay board and a sounder to do this. The connections would be as follows:

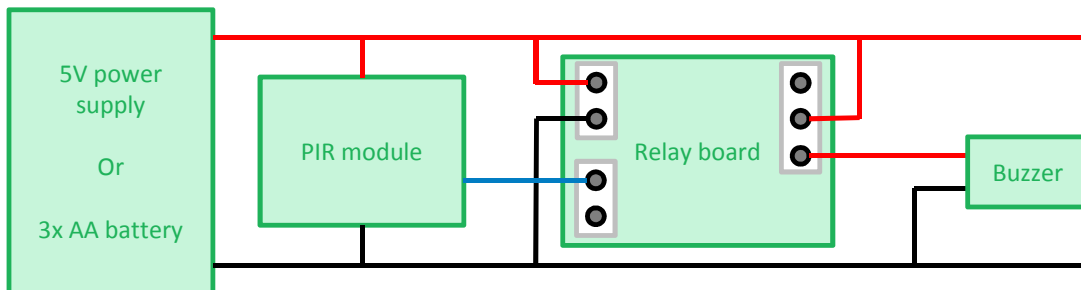

Example application – Automatic green house plant watering system

Since you don't want to water a green house in the heat of the day, why not automatically do it from a water butt at dusk for a set duration. To do this the relay board would be used as follows:

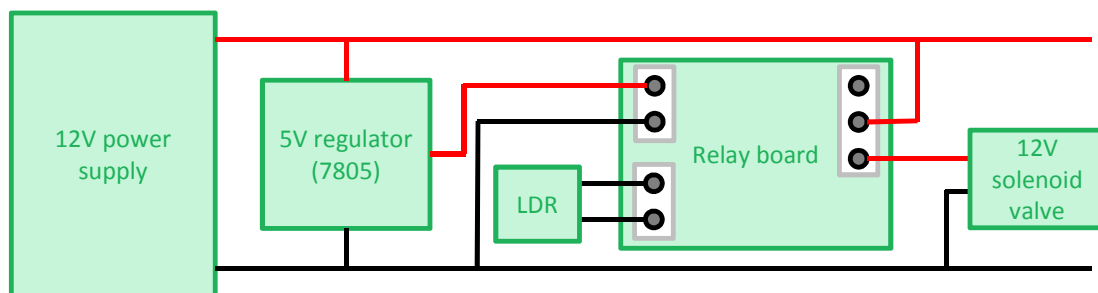

Fault Finding

Fault finding flow chart

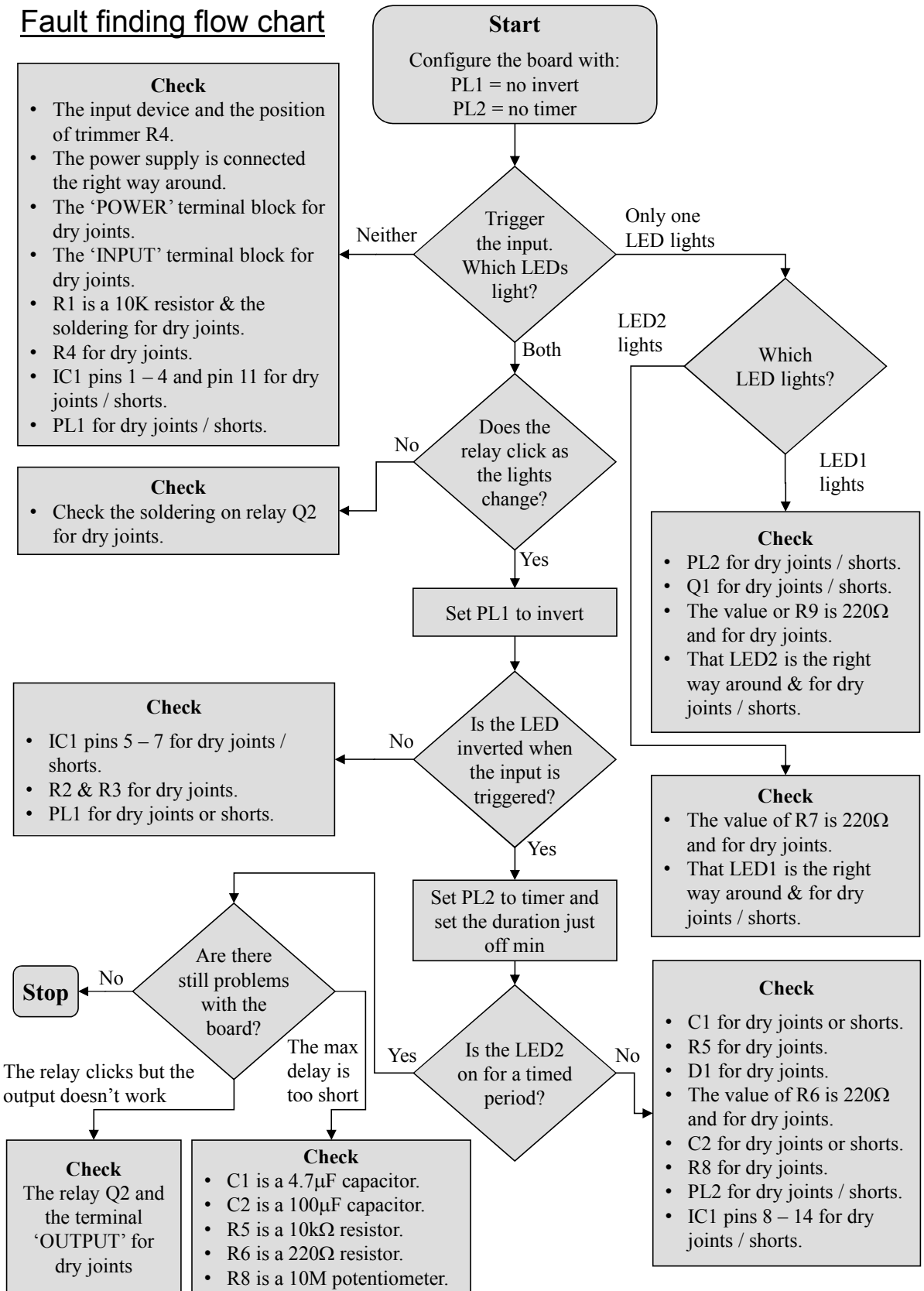

Using relays

Introduction

A relay is a switch that is operated by passing a small amount of current through the coil. When this happens a magnetic field is set up which causes a small strip of metal to move and the switch on the output closes. When the current is turned off to the coil a spring pulls the metal strip open and the switch opens. Typically the coil will take hundreds of mA, whilst the output will switch Amps. Thus the relay allows a small current to drive a bigger current.

The part & circuit symbol

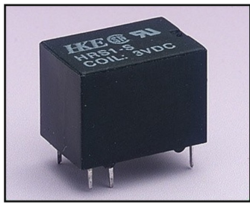

A relay

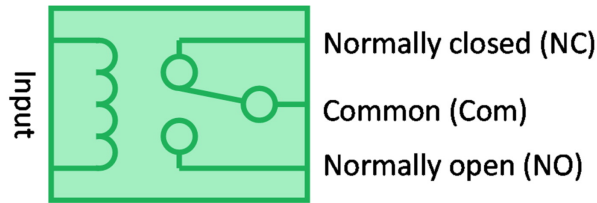

Circuit diagram representation

Connections on a relay

Relays often have three connections on the output switch (as shown above), but can have more or less connections. The Common (Com) connection is connected to the Normally Closed (NC) connection until current is passed through the coil, when the common connects to Normally Open (NO).

In a lot of circuits a device needs to be on when the relay is on, in this case the Com and NO connections are used. Since the relay is a switch a separate circuit including a power source the switch (relay) and a device needs to be connected. This circuit can of course use the same power as the circuit that powers the relay input or can use a higher voltage.

Example circuit

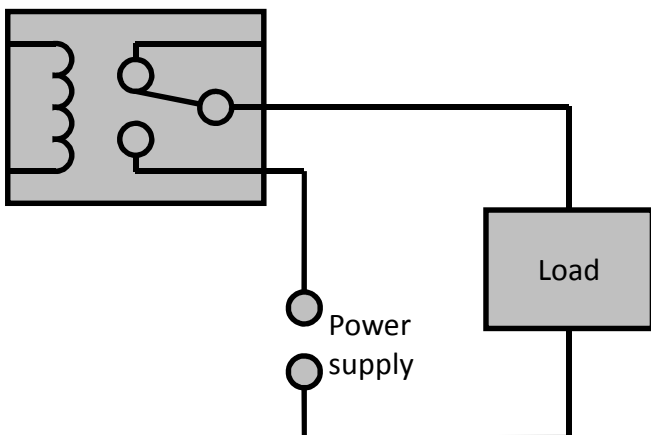

How the Relay board works

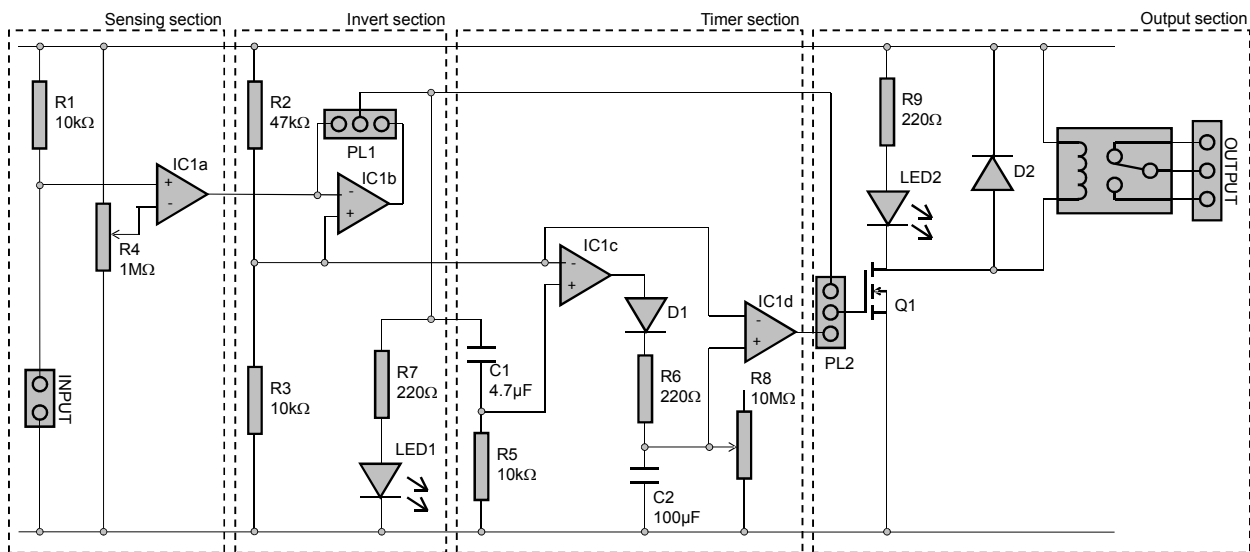

Sensing section - The input device on this circuit, plus the resistor R1 make up a potential divider. As the resistance on the input changes the voltage at the centre point of the potential divider will change. This voltage goes in to the non-inverting input of 'op amp a' on IC1 and is compared to the voltage on the inverting input, which is set by the trimmer potentiometer R4. When the sensor input is bigger than the pre-set input the output of the gate will be high, otherwise it will be low.

Invert section - If a jumper is placed on the left two pins of PL1 then the output from op amp a goes straight to the timer section of the circuit. However if the jumper is placed on the right two pins of PL1 then the output of 'op amp b' is fed through to the timer section. In the second case the signal is inverted, this happens because the non-inverting input on 'op amp b' is held in a known state at about 1V and the output from the sensing op amp goes into the inverting input. This means that if the sensor input is high and greater than 1V the output will be low and if the sensor input is low the output will be high. LED1 shows the state of the sensing section, including the signal being inverted if that option has been selected. The resistor R7 is present to limit the current in to the LED.

Timer section - As the output of the sensing section goes high the capacitor C1 charges through resistor R5. Since C1 is a 4.7μF and R5 is a 10K the timing period on the RC network to charge the capacitor to 2/3 of full capacity is 47mS. Initially C1 has no voltage on it and the non-inverting input of 'op amp c' is high. As the capacitor charges the voltage on the op amp input drops. The inverting input is set at a fixed level of about 1V and when the capacitor gets to within 1V of full charge the two inputs will be the same. At this point in time the output of 'op amp c' goes from a high state to a low state. Because the comparison of charging the capacitor is to 5/6 of full charge (ratio of R2 / R3) rather than 2/3 of full charge the output of IC1 'op amp c' will be longer than 47mS and closer to 100mS.

For the 100mS the output of 'op amp c' is in a high state there is current flowing through the diode D1, resistor R6 and into the capacitor C2. At the end of the period the diode stops the capacitor being discharge when the 'op amp c' output returns to a low state. The time constant of R6 & C2 (22mS) is much smaller than R5 & C1 so C2 should be close to being fully charged (except the voltage drop over the diode). At the end of the 100mS the capacitor C2 is more slowly discharged through the variable resistor R8. In this phase the capacitor starts with voltage on it and this drops down towards zero. The output of 'op amp d' will be on until the voltage on the capacitor reaches about 1V (as set by R2 / R3 and previously mentioned).

Output section - The jumper PL2 gives the option of feeding the input from the sensing section of the circuit into the output section and bypassing the timer or to feed the timer to the output section. Whichever signal is used if it is in a high state the FET Q1 is turned on and LED2 is illuminated and the relay coil is powered changing the state of the relay. The diode D2 is present to get rid of any unwanted spikes when the relay turns off.



Online Information

Two sets of information can be downloaded from the product page where the kit can also be reordered from. The 'Essential Information' contains all of the information that you need to get started with the kit and the 'Teaching Resources' contains more information on soldering, components used in the kit, educational schemes of work and so on and also includes the essentials. Download from:

www.kitronik.co.uk/2144



This kit is designed and manufactured in the UK by Kitronik

Telephone: +44 (0) 845 8380781

Sales email: sales@kitronik.co.uk

Tech support email: support@kitronik.co.uk

Web: www.kitronik.co.uk



www.kitronik.co.uk/twitter



www.kitronik.co.uk/facebook



www.kitronik.co.uk/youtube



www.kitronik.co.uk/google

Every effort has been made to ensure that these notes are correct, however Kitronik accept no responsibility for issues arising from errors / omissions in the notes.

© Kitronik Ltd - Any unauthorised copying / duplication of this booklet or part thereof for purposes except for use with Kitronik project kits is not allowed without Kitronik's prior consent.

