



Description

This product specification is applied to the Humidity Sensor Type HCZ-D5. The terminal electrode material uses lead free solder (Sn / Ag / Cu). This product is conformity with RoHS directive which means that lead, cadmium, mercury, hexavalent chromium and specific bromine-based flame retardants have not been used.

Applications

The applications of the component are used in relative humidity measurement, control and display. There are many end products can be used. For example air conditioner, humidifier, dehumidifier, hygrometer, recorder, transmitter etc.

Diagram

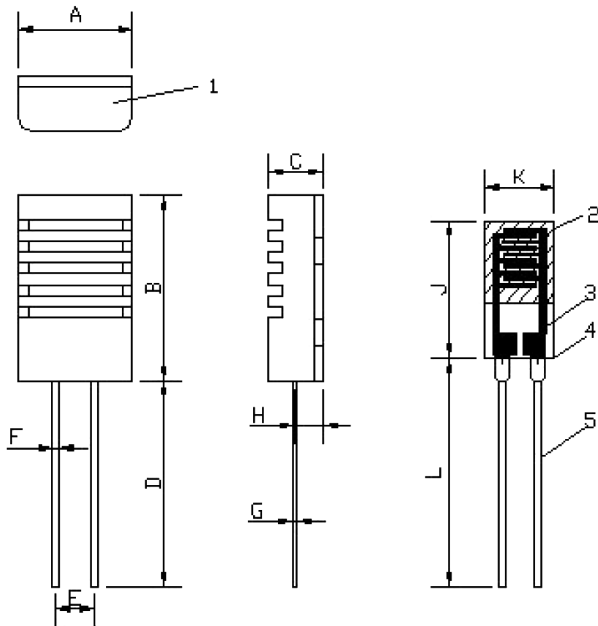

Symbol	Dimension
A	8.3 ±0.2
B	13.5 ±0.2
C	4 ±0.5
D	15 ±2
E	2.54 ±0.2
F	0.5 ±0.1
G	0.2 ±0.1
H	2.0 ±0.5
K	5.08 ±0.3
J	10 ±0.3
L	Min. ≥12

Dimensions : Millimetres

Main Parts

No.	Parts	Material
1	Sensor case	PBT
2	Sensing material	Polymer
3	Electrode	Ag/Carbon
4	Substrate	Alumina
5	Lead frame	Phosphor bronze

Electrical Characteristics

General Characteristics	Units	Min.	Typ.	Max.
Rated Voltage	Vrms	-	-	1
Rated Power	mW	-	-	0.2
Operating Frequency Range	kHz	0.5	1	2
Operating Temperature Range	°C	0	-	60
Operating Humidity Range	%RH	-	-	99
Impedance Range at 60%RH and 25°C**	kΩ	19.3	-	52
Humidity Accuracy	%RH	-5	-	+5
Hysteresis (40%RH~80%RH)	%RH	-	-	2

** Measurement by LCR meter at 1kHz, 1 Vrms(sine wave)

Relative Humidity - Impedance - 25°C, 1kHz, 1 Vrms (Sine wave)

%RH	20	30	40	50	60	70	80	90
Normal value (kΩ)	9210	1480	330	92.8	31	11.7	4.85	2.21

Relative humidity - Impedance curve – measured at 1kHz, 1 Vrms (sine wave)

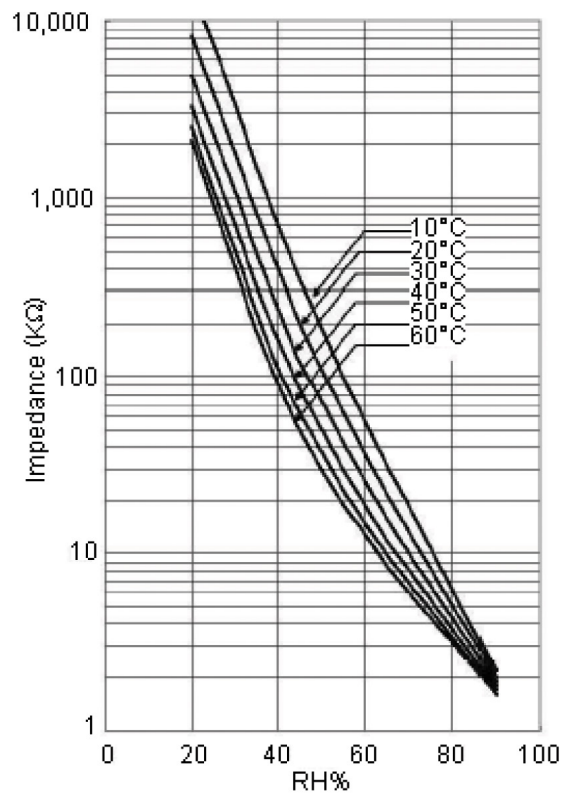

Humidity Sensor



Mechanical Characteristics

Item	Description	Criteria*
Shock Resistance	Drop down 3 times at 80cm	No abnormal appearance and electrical properties
Vibration Resistance	2 hours each in the directions of X-Y-Z, at the frequency of 10-55Hz, and amplitude of 1.5mm	
Resistance to Soldering Heat	The lead terminal shall be Immersed by 3mm from the substrate for 3 seconds in solder bath of 330 ±5°C	
Strength of Terminations	500g at 10 seconds in the axial direction of lead terminal	Secured

Reliability

Item	Description	Criteria*
Heat Resistance	1000 hours @ 70°C	< ±5% RH
Cool Resistance	1000 hours @ -30°C	< ±5% RH
Humidity Resistance	1000 hours @ 60°C, 90%RH	< ±5% RH
Humidity Cycle	Repeat 500 cycles One cycle: 30 minutes @ 25°C, <30%RH 30 minutes @ 25°C, >90%RH	< ±5% RH
Temperature Cycle	Repeat 100 cycles Each cycle: 30 minutes @ -30°C 30 minutes @ 85°C	< ±5% RH
Voltage Resistance	3000 hours @ 1kHz, 1Vrms	< ±5% RH

* The criteria test that the sensors finish the description process after 2 hours under normal temperature and humidity. The test condition is fixed at 25°C, 60%RH by LCR meter at 1kHz, 1 Vrms(sine wave)

Impedance - % RH vs. Temperature

Unit: kΩ

%RH	5°C	10°C	15°C	20°C	25°C	30°C	35°C	40°C	45°C	50°C	55°C
20	34100	24000	17800	13000	9210	6570	4910	3400	2220	1620	1080
25	12600	9000	6670	4870	3150	2550	1900	1350	920	680	470
30	5160	3530	2750	2010	1480	1090	810	590	420	310	230
35	2270	1600	1230	910	670	500	380	280	200	150	120
40	1060	770	590	440	330	250	190	140	110	81.4	62.3
45	530	390	300	220	170	130	100	76.3	58.8	45.5	35.6
50	270	210	160	120	92.8	71.8	55.6	43.3	34.0	26.7	21.3
55	150	110	87.5	67.7	52.7	41.3	32.4	25.6	20.5	16.4	13.3
60	82.9	64.2	50.0	39.3	31.0	24.7	19.7	15.9	12.8	10.4	8.48
65	47.4	37.2	29.4	23.5	18.8	15.1	12.2	10.0	8.18	6.74	5.60
70	27.9	22.2	17.8	14.4	11.7	9.53	7.81	6.48	5.38	4.50	3.78
75	16.8	13.5	11.0	9.06	7.45	6.16	5.13	4.32	3.63	3.07	2.61



Humidity Sensor



Unit: k Ω

%RH	5°C	10°C	15°C	20°C	25°C	30°C	35°C	40°C	45°C	50°C	55°C
80	10.4	8.37	6.91	5.82	4.85	4.08	3.44	2.94	2.50	2.14	1.83
85	6.51	5.31	4.45	3.82	3.24	2.76	2.36	2.05	1.76	1.52	1.31
90	4.17	3.44	2.93	2.57	2.21	1.92	1.66	1.46	1.26	1.11	0.96

Part Number Table

Description	Part Number
Humidity Sensor with Housing	HCZ-D5-A
Humidity Sensor without Housing	HCZ-D5-B

