



Ferrites and accessories

Double-aperture cores

Series/Type: B62152
Date: September 2006

Primarily used for broadband transformers up to high frequencies
Application examples

- SIFERRIT material N30 for low frequencies and for pulse applications
- SIFERRIT material K1 for matching transformers and baluns up to about 250 MHz in antenna feeders or in input circuits of VHF and TV receivers

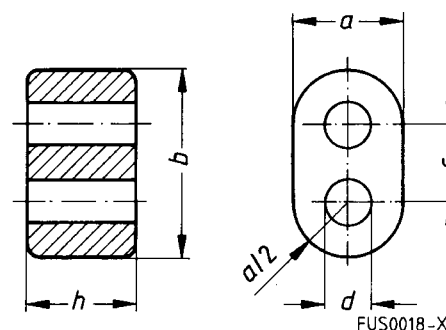

Dimensions ¹⁾					Magnetic characteristics				Weight
h (mm)	b (mm)	a (mm)	c (mm)	d (mm)	$\Sigma l/A^2$ mm ⁻¹	$l_e^{(2)}$ mm	$A_e^{(2)}$ mm ²	$V_e^{(2)}$ mm ³	g
14.5 – 1.0	14.50 – 1.0	8.5 – 0.5	5.85 ±0.25	3.4 + 0.80	0.31	15.3	49.7	760	4.0
8.3 – 0.6	14.50 – 1.0	8.5 – 0.5	5.85 ±0.25	3.4 + 0.60	0.54	15.3	28.4	435	2.5
6.2 – 0.5	7.25 – 0.5	4.2 – 0.4	2.90 ±0.15	1.7 + 0.30	0.75	7.6	10.2	78	0.4
2.5 – 0.2	3.60 – 0.3	2.1 – 0.3	1.45 ±0.10	0.8 + 0.15	1.78	3.7	2.1	7.8	0.1
2.0 – 0.2	3.60 – 0.3	2.1 – 0.3	1.45 ±0.10	0.8 + 0.15	2.20	3.7	1.7	6.3	0.1

Overview of available types

Core height h (mm)	Material	A_L value ²⁾ nH (Tol. ±30%)	Ordering code ³⁾
14.5 – 1.0	K1	330	B62152A0001X001
8.3 – 0.6	K1 N30	190 10000	B62152A0004X001 B62152A0004X030
6.2 – 0.5	K1 N30	140 7300	B62152A0007X001 B62152A0007X030
2.5 – 0.2	K1 N30 M13	60 3100 1440	B62152A0008X001 B62152A0008X030 B62152A0008X013
2.0 – 0.2	K1 N30 M13	42 2400 1100	B62152A0027X001 B62152A0027X030 B62152A0027X013

1) Cores made of NiZn ferrite may exceed the specified dimensions by up to 5%.

2) Magnetic characteristics and A_L value are based on winding of center leg.

3) Double-aperture cores are available with parylene coating on request. In this case the thickness of the coating is approx. 10 to 15 µm. Ordering code for coated version: B62152P...

Mechanical stress and mounting

Ferrite cores have to meet mechanical requirements during assembling and for a growing number of applications. Since ferrites are ceramic materials one has to be aware of the special behavior under mechanical load.

As valid for any ceramic material, ferrite cores are brittle and sensitive to any shock, fast changing or tensile load. Especially high cooling rates under ultrasonic cleaning and high static or cyclic loads can cause cracks or failure of the ferrite cores.

For detailed information see Data Book 2007, chapter “General – Definitions, 8.1”.

Effects of core combination on A_L value

Stresses in the core affect not only the mechanical but also the magnetic properties. It is apparent that the initial permeability is dependent on the stress state of the core. The higher the stresses are in the core, the lower is the value for the initial permeability. Thus the embedding medium should have the greatest possible elasticity.

For detailed information see Data Book 2007, chapter “General – Definitions, 8.2”.

Heating up

Ferrites can run hot during operation at higher flux densities and higher frequencies.

NiZn-materials

The magnetic properties of NiZn-materials can change irreversible in high magnetic fields.

Processing notes

- The start of the winding process should be soft. Else the flanges may be destroyed.
- To strong winding forces may blast the flanges or squeeze the tube that the cores can no more be mount.
- To long soldering time at high temperature (>300 °C) may effect coplanarity or pin arrangement.
- Not following the processing notes for soldering of the J-leg terminals may cause solderability problems at the transformer because of pollution with Sn oxyd of the tin bath or burned insulation of the wire. For detailed information see Data Book 2007, chapter “Processing notes, 2.2”.
- The dimensions of the hole arrangement have fixed values and should be understood as a recommendation for drilling the printed circuit board. For dimensioning the pins, the group of holes can only be seen under certain conditions, as they fit into the given hole arrangement. To avoid problems when mounting the transformer, the manufacturing tolerances for positioning the customers’ drilling process must be considered by increasing the hole diameter.

Important notes

The following applies to all products named in this publication:

1. Some parts of this publication contain **statements about the suitability of our products for certain areas of application**. These statements are based on our knowledge of typical requirements that are often placed on our products in the areas of application concerned. We nevertheless expressly point out **that such statements cannot be regarded as binding statements about the suitability of our products for a particular customer application**. As a rule, EPCOS is either unfamiliar with individual customer applications or less familiar with them than the customers themselves. For these reasons, it is always ultimately incumbent on the customer to check and decide whether an EPCOS product with the properties described in the product specification is suitable for use in a particular customer application.
2. We also point out that **in individual cases, a malfunction of passive electronic components or failure before the end of their usual service life cannot be completely ruled out in the current state of the art, even if they are operated as specified**. In customer applications requiring a very high level of operational safety and especially in customer applications in which the malfunction or failure of a passive electronic component could endanger human life or health (e.g. in accident prevention or life-saving systems), it must therefore be ensured by means of suitable design of the customer application or other action taken by the customer (e.g. installation of protective circuitry or redundancy) that no injury or damage is sustained by third parties in the event of malfunction or failure of a passive electronic component.
3. **The warnings, cautions and product-specific notes must be observed.**
4. In order to satisfy certain technical requirements, **some of the products described in this publication may contain substances subject to restrictions in certain jurisdictions (e.g. because they are classed as “hazardous”)**. Useful information on this will be found in our Material Data Sheets on the Internet (www.epcos.com/material). Should you have any more detailed questions, please contact our sales offices.
5. We constantly strive to improve our products. Consequently, **the products described in this publication may change from time to time**. The same is true of the corresponding product specifications. Please check therefore to what extent product descriptions and specifications contained in this publication are still applicable before or when you place an order.
We also **reserve the right to discontinue production and delivery of products**. Consequently, we cannot guarantee that all products named in this publication will always be available.
6. Unless otherwise agreed in individual contracts, **all orders are subject to the current version of the “General Terms of Delivery for Products and Services in the Electrical Industry” published by the German Electrical and Electronics Industry Association (ZVEI)**.
7. The trade names EPCOS, EPCOS-JONES, Baoke, Alu-X, CeraDiode, CSSP, MLSC, PhaseCap, PhaseMod, SIFI, SIFERRIT, SIKOREL, SilverCap, SIMID, SIOV, SIP5D, SIP5K, UltraCap, WindCap are **trademarks registered or pending** in Europe and in other countries. Further information will be found on the Internet at www.epcos.com/trademarks.