

MOTOROLA
SEMICONDUCTOR
TECHNICAL DATA

Fiber Optics — FLCS Family

Photo Detector

Diode Output

The MFOD71 is designed for low cost, short distance Fiber Optic Systems using 1000 micron core plastic fiber

Features:

- Fast PIN Photodiode. Response Time < 5 ns
- Ideally Matched to MFOE76 Emitter for Plastic Fiber Systems
- Annular Passivated Structure for Stability and Reliability
- FLCS Package
 - Includes Connector
 - Simple Fiber Termination and Connection (Figure 4)
 - Easy Board Mounting
 - Molded Lens for Efficient Coupling
 - Mates with 1000 Micron Core Plastic Fiber (Eska SH4001)

Applications:

- Medical Electronics
- Industrial Controls
- Security Systems
- Short Haul Communication Systems
- High Isolation Interconnects
- M6800 Microprocessor Systems

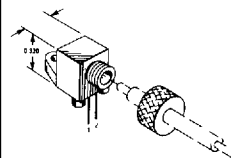
MFOD71
FLCS FAMILY
FIBER OPTICS
PHOTO DETECTOR
DIODE OUTPUT

CASE 363B-01
PLASTIC
STYLE 3
MAXIMUM RATINGS ($T_A = 25^\circ\text{C}$ unless otherwise noted)

Rating	Symbol	Value	Unit
Reverse Voltage	MFOD71 V_R	100	Volts
Total Power Dissipation @ $T_A = 25^\circ\text{C}$ Derate above 25°C	P_D	150 2	mW mW/°C
Operating and Storage Junction Temperature Range	T_J, T_{stg}	-40 to +100	°C

ELECTRICAL CHARACTERISTICS ($T_A = 25^\circ\text{C}$ unless otherwise noted)

Characteristic	Symbol	Min	Typ	Max	Unit
Dark Current ($V_R = 20\text{ V}, R_L = 1\text{ M}\Omega$) $T_A = 25^\circ\text{C}$ $T_A = 85^\circ\text{C}$	I_D	— —	0.06 10	10 —	nA
Reverse Breakdown Voltage ($I_R = 10\ \mu\text{A}$)	$V_{(BR)R}$	50	100	—	Volts
Forward Voltage ($I_F = 50\text{ mA}$)	V_F	—	—	1.1	Volts
Series Resistance ($I_F = 50\text{ mA}$)	R_S	—	8	—	Ohms
Total Capacitance ($V_R = 20\text{ V}, f = 1\text{ MHz}$)	C_T	—	3	—	pF

OPTICAL CHARACTERISTICS ($T_A = 25^\circ\text{C}$)

Characteristic	Symbol	Min	Typ	Max	Unit
Responsivity ($V_R = 5\text{ V}$, Figure 2)	R	0.15	0.2	—	$\mu\text{A}/\mu\text{W}$
Response Time ($V_R = 5\text{ V}, R_L = 50\ \Omega$)	$t_{(resp)}$	—	5	—	ns

TYPICAL COUPLED CHARACTERISTICS

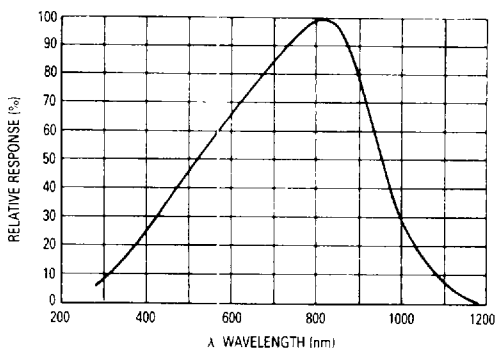

Figure 1. Relative Spectral Response

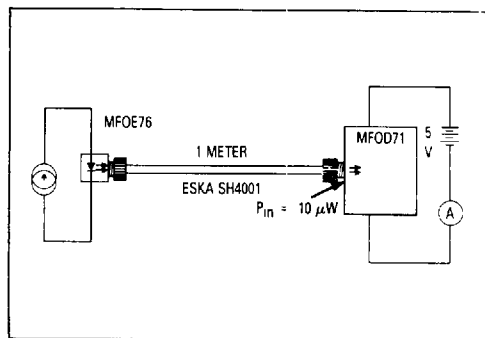

Figure 2. Responsivity Test Configuration

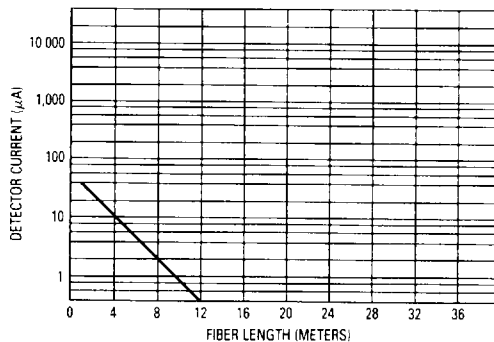

Figure 3. Detector Current versus Fiber Length

The system length achieved with a MFOE76 emitter and various detectors, using 1000 micron core plastic fiber (Eska SH4001 or equivalent), depends on the LED forward

current (I_f) and the responsivity of the detector chosen. Each detector will perform with the MFOE76 up to the distances shown below.

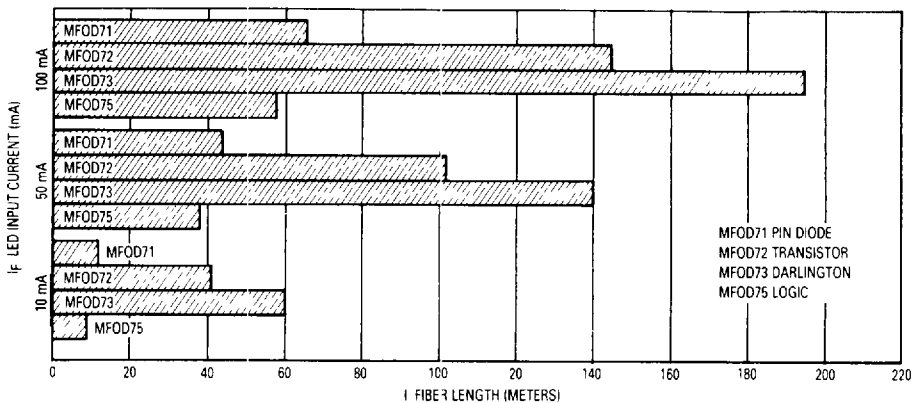

Figure 4. MFOE76 Working Distances

MFOD71

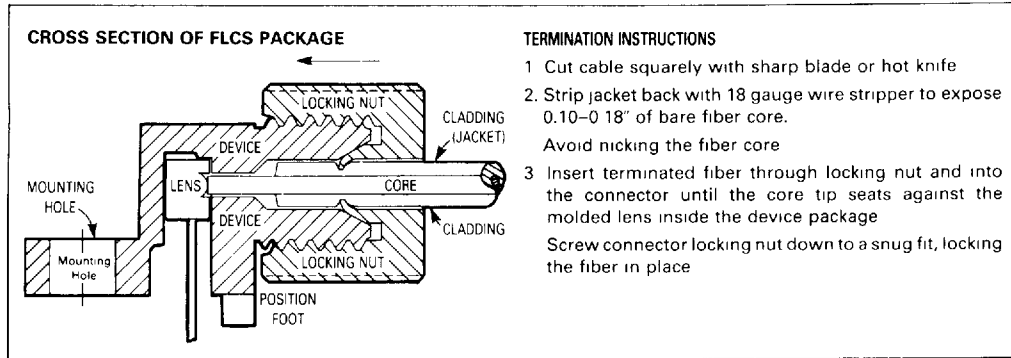

Figure 5. FO Cable Termination and Assembly

INPUT SIGNAL CONDITIONING

The following circuits are suggested to provide the desired forward current through the emitter.

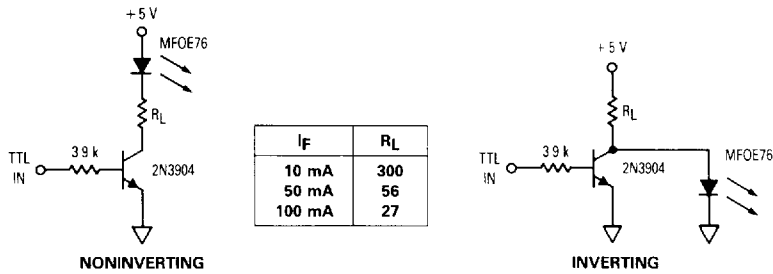
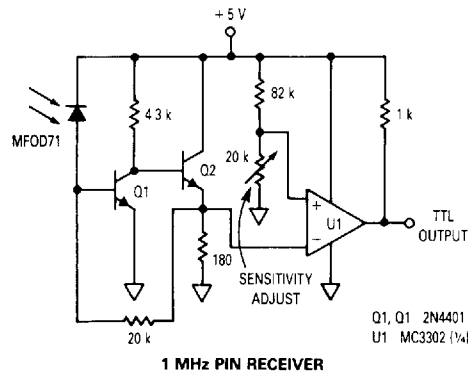

Figure 6. TTL Transmitters

OUTPUT SIGNAL CONDITIONING

The following circuit is suggested to take the MFOD71 detector output and condition it to drive TTL with an acceptable bit error rate.



1 MHz PIN RECEIVER
Figure 7. TTL Receiver