

# Tiva™ C Series TM4C123G LaunchPad Evaluation Board

## User's Guide



Literature Number: SPMU296

April 2013

---



---



---

<b>1</b>	<b>Board Overview</b> .....	<b>4</b>
1.1	Kit Contents .....	5
1.2	Using the Tiva C Series LaunchPad .....	5
1.3	Features .....	5
1.4	BoosterPacks .....	6
1.5	Specifications .....	6
<b>2</b>	<b>Hardware Description</b> .....	<b>7</b>
2.1	Functional Description .....	7
2.1.1	Microcontroller .....	7
2.1.2	USB Connectivity .....	8
2.1.3	Motion Control .....	8
2.1.4	User Switches and RGB User LED .....	9
2.1.5	Headers and BoosterPacks .....	9
2.2	Power Management .....	11
2.2.1	Power Supplies .....	11
2.2.2	Hibernate .....	11
2.2.3	Clocking .....	12
2.2.4	Reset .....	12
2.3	In-Circuit Debug Interface (ICDI) .....	12
2.3.1	Virtual COM Port .....	12
<b>3</b>	<b>Software Development</b> .....	<b>13</b>
3.1	Software Description .....	13
3.2	Source Code .....	13
3.3	Tool Options .....	13
3.4	Programming the Tiva C Series LaunchPad Evaluation Board .....	14
<b>4</b>	<b>References, PCB Layout, and Bill of Materials</b> .....	<b>15</b>
4.1	References .....	15
4.2	Component Locations .....	16
4.3	Bill of Materials (BOM) .....	17
<b>A</b>	<b>Schematics</b> .....	<b>19</b>

## List of Figures

1-1.	Tiva C Series TM4C123G LaunchPad Evaluation Board.....	4
2-1.	Tiva C Series LaunchPad Evaluation Board Block Diagram.....	7
4-1.	Tiva C Series LaunchPad Component Locations (Top View).....	16
4-2.	Tiva C Series LaunchPad Dimensions.....	17

## List of Tables

1-1.	EK-TM4C123GXL Specifications.....	6
2-1.	USB Device Signals.....	8
2-2.	User Switches and RGB LED Signals.....	9
2-3.	J1 Connector.....	9
2-4.	J2 Connector.....	10
2-5.	J3 Connector.....	10
2-6.	J4 Connector.....	11
2-7.	In-Circuit Debug Interface (ICDI) Signals.....	12
2-8.	Virtual COM Port Signals.....	12
4-1.	EK-TM4C123GXL Bill of Materials.....	17

## Board Overview

The Tiva™ C Series TM4C123G LaunchPad Evaluation Board ([EK-TM4C123GXL](#)) is a low-cost evaluation platform for ARM® Cortex™-M4F-based microcontrollers. The Tiva C Series LaunchPad design highlights the [TM4C123GH6PMI](#) microcontroller USB 2.0 device interface, hibernation module, and motion control pulse-width modulator (MC PWM) module. The Tiva C Series LaunchPad also features programmable user buttons and an RGB LED for custom applications. The stackable headers of the Tiva C Series TM4C123G LaunchPad BoosterPack XL interface demonstrate how easy it is to expand the functionality of the Tiva C Series LaunchPad when interfacing to other peripherals on many existing BoosterPack add-on boards as well as future products. [Figure 1-1](#) shows a photo of the Tiva C Series LaunchPad.

**Figure 1-1. Tiva C Series TM4C123G LaunchPad Evaluation Board**

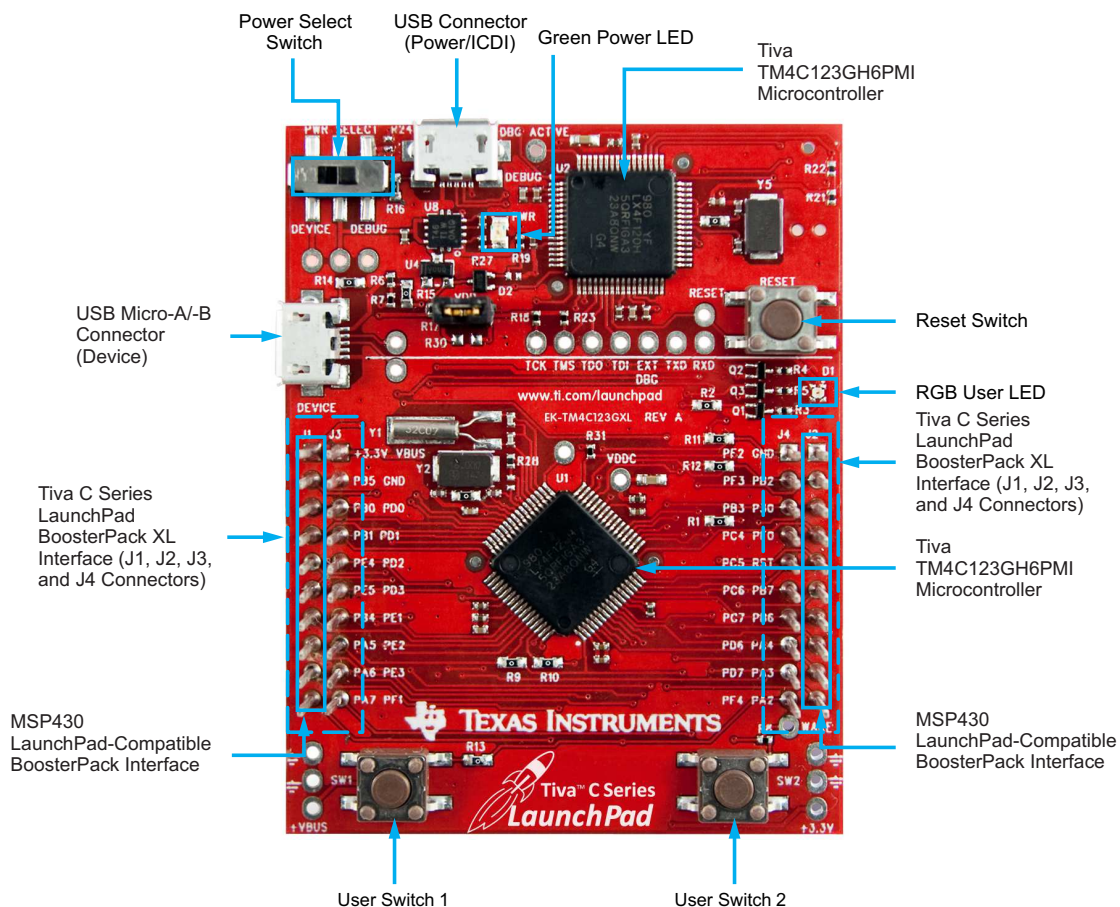

Tiva, MSP430, Code Composer Studio are trademarks of Texas Instruments.  
Cortex is a trademark of ARM Limited.  
ARM, RealView are registered trademarks of ARM Limited.  
Microsoft, Windows are registered trademarks of Microsoft Corporation.  
All other trademarks are the property of their respective owners.

## 1.1 Kit Contents

The Tiva C Series TM4C123G LaunchPad Evaluation Kit contains the following items:

- Tiva C Series LaunchPad Evaluation Board (EK-TM4C123GXL)
- On-board In-Circuit Debug Interface (ICDI)
- USB micro-B plug to USB-A plug cable
- [README First](#) document

## 1.2 Using the Tiva C Series LaunchPad

The recommended steps for using the Tiva C Series TM4C123G LaunchPad Evaluation Kit are:

1. **Follow the README First document included in the kit.** The README First document will help you get the Tiva C Series LaunchPad up and running in minutes. See the [Tiva C Series LaunchPad web page](#) for additional information to help you get started.
2. **Experiment with LaunchPad BoosterPacks.** A selection of Tiva C Series BoosterPacks and compatible MSP430™ BoosterPacks can be found at the [TI MCU LaunchPad web page](#).
3. **Take your first step toward developing an application with Project 0 using your preferred ARM tool-chain and the Tiva C Series TivaWare Peripheral Driver Library.** Software applications are loaded using the on-board In-Circuit Debug Interface (ICDI). See [Chapter 3, Software Development](#), for the programming procedure. The [TivaWare for C Series Peripheral Driver Library Software Reference Manual](#) contains specific information on software structure and function. For more information on Project 0, go to the [Tiva C Series LaunchPad wiki page](#).
4. **Customize and integrate the hardware to suit an end application.** This user's manual is an important reference for understanding circuit operation and completing hardware modification.

You can also view and download almost six hours of training material on configuring and using the LaunchPad. Visit the [Tiva C Series LaunchPad Workshop](#) for more information and tutorials.

## 1.3 Features

Your Tiva C Series LaunchPad includes the following features:

- Tiva TM4C123GH6PMI microcontroller
- Motion control PWM
- USB micro-A and micro-B connector for USB device, host, and on-the-go (OTG) connectivity
- RGB user LED
- Two user switches (application/wake)
- Available I/O brought out to headers on a 0.1-in (2.54-mm) grid
- On-board ICDI
- Switch-selectable power sources:
  - ICDI
  - USB device
- Reset switch
- Preloaded RGB quickstart application
- Supported by TivaWare for C Series software including the USB library and the peripheral driver library
- Tiva C Series TM4C123G LaunchPad BoosterPack XL Interface, which features stackable headers to expand the capabilities of the Tiva C Series LaunchPad development platform
  - For a complete list of available BoosterPacks that can be used with the Tiva C Series LaunchPad, see the [LaunchPad web page](#).

## 1.4 BoosterPacks

The Tiva C Series LaunchPad provides an easy and inexpensive way to develop applications with the TM4C123GH6PM microcontroller. Tiva C Series BoosterPacks and MSP430 BoosterPacks expand the available peripherals and potential applications of the Tiva C Series LaunchPad. BoosterPacks can be used with the Tiva C Series LaunchPad or you can simply use the on-board TM4C123GH6PM microcontroller as its processor. See [Chapter 2](#) for more information.

Build your own BoosterPack and take advantage of [Texas Instruments' website](#) to help promote it! From sharing a new idea or project, to designing, manufacturing, and selling your own BoosterPack kit, TI offers a variety of avenues for you to reach potential customers with your solutions.

## 1.5 Specifications

[Table 1-1](#) summarizes the specifications for the Tiva C Series LaunchPad.

**Table 1-1. EK-TM4C123GXL Specifications**

Parameter	Value
Board supply voltage	4.75 V <sub>DC</sub> to 5.25 V <sub>DC</sub> from one of the following sources: <ul style="list-style-type: none"> <li>• Debugger (ICDI) USB Micro-B cable (connected to a PC)</li> <li>• USB Device Micro-B cable (connected to a PC)</li> </ul>
Dimensions	2.0 in x 2.25 in x 0.425 in (5.0 cm x 5.715 cm x 10.795 mm) (L x W x H)
Break-out power output	<ul style="list-style-type: none"> <li>• 3.3 V<sub>DC</sub> (300 mA max)</li> <li>• 5.0 V<sub>DC</sub> (depends on 3.3 V<sub>DC</sub> usage, 23 mA to 323 mA)</li> </ul>
RoHS status	Compliant

## Hardware Description

The Tiva C Series LaunchPad includes a TM4C123GH6PM microcontroller and an integrated ICDI as well as a range of useful peripheral features (as the block diagram in Figure 2-1 shows). This chapter describes how these peripherals operate and interface to the microcontroller.

**Figure 2-1. Tiva C Series LaunchPad Evaluation Board Block Diagram**

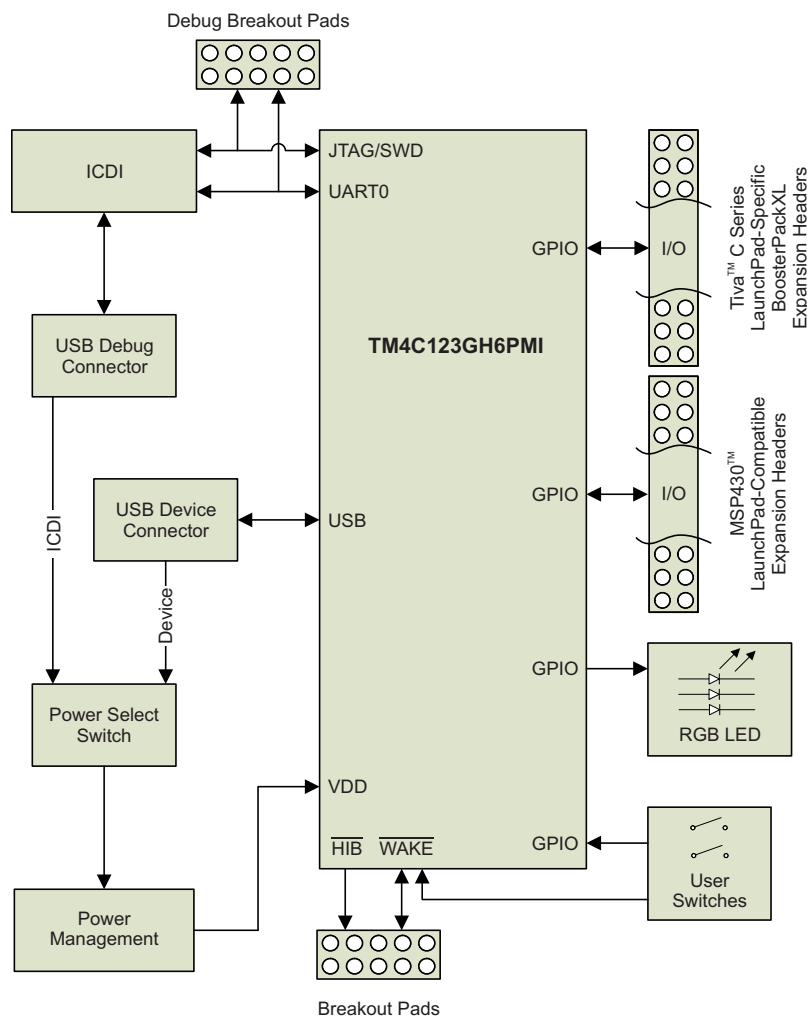

## 2.1 Functional Description

### 2.1.1 Microcontroller

The TM4C123GH6PM is a 32-bit ARM Cortex-M4-based microcontroller with 256-kB Flash memory, 32-kB SRAM, and 80-MHz operation; USB host, device, and OTG connectivity; a Hibernation module and PWM; and a wide range of other peripherals. See the [TM4C123GH6PM microcontroller data sheet](#) (literature number [SPMS376](#)) for complete device details.

Most of the microcontroller signals are routed to 0.1-in (2.54-mm) pitch headers. An internal multiplexer allows different peripheral functions to be assigned to each of these GPIO pads. When adding external circuitry, consider the additional load on the evaluation board power rails.

The TM4C123GH6PM microcontroller is factory-programmed with a quickstart demo program. The quickstart program resides in on-chip Flash memory and runs each time power is applied, unless the quickstart application has been replaced with a user program.

### 2.1.2 USB Connectivity

The EK-TM4C123GXL is designed and functions as a USB device without hardware modification. The USB device signals are dedicated to USB functionality and are not shared with the BoosterPack headers. The USB device signals are listed in [Table 2-1](#).

**Table 2-1. USB Device Signals**

GPIO Pin	Pin Function	USB Device
PD4	USB0DM	D-
PD5	USB0DP	D+

The TM4C123GH6PM target device is also capable of USB embedded host and on-the-go (OTG) functions. OTG functionality can be enabled by populating R25 and R29 with 0-Ω resistors. These resistors connect the USB ID and USB  $V_{BUS}$  signals to PB0 and PB1. When these resistors are populated, PB0 and PB1 must remain in the respective USB pin mode configurations to prevent device damage. PB0 and PB1 are also present on the J1 BoosterPack header. Therefore, if R25 or R29 are populated, care must be taken not to conflict these signals with BoosterPack signals.

USB embedded host operation can be enabled in the same way for USB devices that are self-powered. Providing power when acting as a USB host requires a BoosterPack with power switching and appropriate connectors. All USB host signals are available on the BoosterPack interface except D+ and D-, which are only available on the USB micro-A/B connector and the two adjacent test points.

When connected as a USB device, the evaluation board can be powered from either the ICD1 or the USB Device connectors. The user can select the power source by moving the POWER SELECT switch (SW3) to the Device position. See the *Power Management* schematic (appended to this document).

### 2.1.3 Motion Control

The EK-TM4C123GXL includes the Tiva C-Series Motion Control PWM technology, featuring two PWM modules capable of generating 16 PWM outputs. Each PWM module provides a great deal of flexibility and can generate simple PWM signals—for example, those required by a simple charge pump—as well as paired PWM signals with dead-band delays, such as those required by a half-H bridge driver. Three generator blocks can also generate the full six channels of gate controls required by a 3-phase inverter bridge.

Two quadrature encoder interfaces (QE1) are also available to provide motion control feedback. See the [Headers and BoosterPacks](#) section of this document for details about the availability of these signals on the BoosterPack interface.



### 2.1.4 User Switches and RGB User LED

The Tiva C Series LaunchPad comes with an RGB LED. This LED is used in the preloaded RGB quickstart application and can be configured for use in custom applications.

Two user buttons are included on the board. The user buttons are both used in the preloaded quickstart application to adjust the light spectrum of the RGB LED as well as go into and out of hibernation. The user buttons can be used for other purposes in the user's custom application.

The evaluation board also has a green power LED. [Table 2-2](#) shows how these features are connected to the pins on the microcontroller.

**Table 2-2. User Switches and RGB LED Signals**

GPIO Pin	Pin Function	USB Device
PF4	GPIO	SW1
PF0	GPIO	SW2
PF1	GPIO	RGB LED (Red)
PF2	GPIO	RGB LED (Blue)
PF3	GPIO	RGB LED (Green)

### 2.1.5 Headers and BoosterPacks

The two double rows of stackable headers are mapped to most of the GPIO pins of the TM4C123GH6PM microcontroller. These rows are labeled as connectors J1, J2, J3, and J4. Connectors J3 and J4 are located 0.1 in (2.54 mm) inside of the J1 and J2 connectors. All 40 header pins of the J1, J2, J3, and J4 connectors make up the Tiva C Series TM4C123G LaunchPad BoosterPack XL Interface. [Table 2-3](#) through [Table 2-6](#) show how these header pins are connected to the microcontroller pins and which GPIO functions can be selected.

---

**NOTE:** To configure the device peripherals easily and intuitively using a graphical user interface (GUI), see the Tiva C Series Pinmux Utility found at [www.ti.com/tool/lm4f\\_pinmux](http://www.ti.com/tool/lm4f_pinmux). This easy-to-use interface makes setting up alternate functions for GPIOs simple and error-free.

---

**Table 2-3. J1 Connector<sup>(1)</sup>**

J1 Pin	GPIO	Analog Function	On-board Function	Tiva C Series MCU Pin	GPIOCTL Register Setting										
		GPIO AMSEL			1	2	3	4	5	6	7	8	9	14	15
1.01					3.3 V										
1.02	PB5	AIN11	–	57	–	SSI2Fss	–	M0PWM3	–	–	T1CCP1	CAN0Tx	–	–	–
1.03	PB0	USB0ID	–	45	U1Rx	–	–	–	–	–	T2CCP0	–	–	–	–
1.04	PB1	USB0VBUS	–	46	U1Tx	–	–	–	–	–	T2CCP1	–	–	–	–
1.05	PE4	AIN9	–	59	U5Rx	–	I2C2SCL	M0PWM4	M1PWM2	–	–	CAN0Rx	–	–	–
1.06	PE5	AIN8	–	60	U5Tx	–	I2C2SDA	M0PWM5	M1PWM3	–	–	CAN0Tx	–	–	–
1.07	PB4	AIN10	–	58	–	SSI2Clk	–	M0PWM2	–	–	T1CCP0	CAN0Rx	–	–	–
1.08	PA5	–	–	22	–	SSI0Tx	–	–	–	–	–	–	–	–	–
1.09	PA6	–	–	23	–	–	I2C1SCL	–	M1PWM2	–	–	–	–	–	–
1.10	PA7	–	–	24	–	–	I2C1SDA	–	M1PWM3	–	–	–	–	–	–

<sup>(1)</sup> Shaded cells indicate configuration for compatibility with the MSP430 LaunchPad.

**Table 2-4. J2 Connector<sup>(1)</sup>**

J2 Pin	GPIO	Analog Function	On-board Function	Tiva C Series MCU Pin	GPIOPCTL Register Setting										
		GPIO AMSEL			1	2	3	4	5	6	7	8	9	14	15
2.01					GND										
2.02	PB2	–	–	47	–	–	I2C0SCL	–	–	–	T3CCP0	–	–	–	–
2.03	PE0	AIN3	–	9	U7Rx	–	–	–	–	–	–	–	–	–	–
2.04	PF0	–	USR_SW2/WAKE (R1)	28	U1RTS	SSI1Rx	CAN0Rx	–	M1PWM4	PhA0	T0CCP0	NMI	C0o	–	–
2.05					RESET										
2.06	PB7	–	–	4	–	SSI2Tx	–	M0PWM1	–	–	T0CCP1	–	–	–	–
	PD1	AIN6	Connected for MSP430 Compatibility (R10)	62	SSI3Fss	SSI1Fss	I2C3SDA	M0PWM7	M1PWM1	–	WT2CCP1	–	–	–	–
2.07	PB6	–	–	1	–	SSI2Rx	–	M0PWM0	–	–	T0CCP0	–	–	–	–
	PD0	AIN7	Connected for MSP430 Compatibility (R9)	61	SSI3Clk	SSI1Clk	I2C3SCL	M0PWM6	M1PWM0	–	WT2CCP0	–	–	–	–
2.08	PA4	–	–	21	–	SSIORx	–	–	–	–	–	–	–	–	–
2.09	PA3	–	–	20	–	SSIOFss	–	–	–	–	–	–	–	–	–
2.10	PA2	–	–	19	–	SSIOClk	–	–	–	–	–	–	–	–	–

<sup>(1)</sup> Shaded cells indicate configuration for compatibility with the MSP430 LaunchPad.

**Table 2-5. J3 Connector<sup>(1)</sup>**

J3 Pin	GPIO	Analog Function	On-board Function	Tiva C Series MCU Pin	GPIOPCTL Register Setting										
		GPIO AMSEL			1	2	3	4	5	6	7	8	9	14	15
3.01					5.0 V										
3.02					GND										
3.03	PD0	AIN7	–	61	SSI3Clk	SSI1Clk	I2C3SCL	M0PWM6	M1PWM0	–	WT2CCP0	–	–	–	–
	PB6	–	Connected for MSP430 Compatibility (R9)	1	–	SSI2Rx	–	M0PWM0	–	–	T0CCP0	–	–	–	–
3.04	PD1	AIN6	–	92	SSI3Fss	SSI1Fss	I2C3SDA	M0PWM7	M1PWM1	–	WT2CCP1	–	–	–	–
	PB7	–	Connected for MSP430 Compatibility (R10)	4	–	SSI2Tx	–	M0PWM1	–	–	T0CCP1	–	–	–	–
3.05	PD2	AIN5	–	63	SSI3Rx	SSI1Rx	–	M0FAULT0	–	–	WT3CCP0	USB0EPEN	–	–	–
3.06	PD3	AIN4	–	64	SSI3Tx	SSI1Tx	–	–	–	–	WT3CCP1	USB0PFLT	–	–	–
3.07	PE1	AIN2	–	8	U7Tx	–	–	–	–	–	–	–	–	–	–
3.08	PE2	AIN1	–	7	–	–	–	–	–	–	–	–	–	–	–
3.09	PE3	AIN0	–	6	–	–	–	–	–	–	–	–	–	–	–
3.10	PF1	–	–	29	U1CTS	SSI1Tx	–	–	M1PWM5	–	T0CCP1	–	C1o	TRD1	–

<sup>(1)</sup> Shaded cells indicate configuration for compatibility with the MSP430 LaunchPad.

**Table 2-6. J4 Connector**

J4 Pin	GPIO	Analog Function GPIO AMSEL	On-board Function	Tiva C Series MCU Pin	GPIOCTL Register Setting										
					1	2	3	4	5	6	7	8	9	14	15
4.01	PF2	–	Blue LED (R11)	30	–	SSI1Clk	–	M0FAULT0	M1PWM6	–	T1CCP0	–	–	–	TRD0
4.02	PF3	–	Green LED (R12)	31	–	SSI1Fss	CAN0Tx	–	M1PWM7	–	T1CCP1	–	–	–	TRCLK
4.03	PB3	–	–	48	–	–	I2C0SDA	–	–	–	T3CCP1	–	–	–	–
4.04	PC4	C1–	–	16	U4Rx	U1Rx	–	M0PWM6	–	IDX1	WT0CCP0	U1RTS	–	–	–
4.05	PC5	C1+	–	15	U4Tx	U1Tx	–	M0PWM7	–	PhA1	WT0CCP1	U1CTS	–	–	–
4.06	PC6	C0+	–	14	U3Rx	–	–	–	–	PhB1	WT1CCP0	USB0EPE N	–	–	–
4.07	PC7	C0–	–	13	U3Tx	–	–	–	–	–	WT1CCP1	USB0PFLT	–	–	–
4.08	PD6	–	–	53	U2Rx	–	–	–	–	PhA0	WT5CCP0	–	–	–	–
4.09	PD7	–	–	10	U2Tx	–	–	–	–	PhB0	WT5CCP1	NMI	–	–	–
4.10	PF4	–	USR_SW 1 (R13)	5	–	–	–	–	M1FAULT0	IDX0	T2CCP0	USB0EPE N	–	–	–

Connectors J1 and J2 of the Tiva C Series TM4C123G LaunchPad BoosterPack XL Interface provide compatibility with MSP430 LaunchPad BoosterPacks. Highlighted functions (shaded cells) in [Table 2-3](#) through [Table 2-5](#) indicate configuration for compatibility with the MSP430 LaunchPad.

A complete list of Tiva C Series BoosterPacks and Tiva C Series LaunchPad-compatible MSP430 BoosterPacks is available at [www.ti.com/tm4c123g-launchpad](http://www.ti.com/tm4c123g-launchpad).

## 2.2 Power Management

### 2.2.1 Power Supplies

The Tiva C Series LaunchPad can be powered from one of two power sources:

- On-board ICDI USB cable (Debug, Default)
- USB device cable (Device)

The POWER SELECT switch (SW3) is used to select one of the two power sources. Select only one source at a time.

### 2.2.2 Hibernate

The Tiva C Series LaunchPad provides an external 32.768-kHz crystal (Y1) as the clock source for the TM4C123GH6PM Hibernation module clock source. The current draw while in Hibernate mode can be measured by making some minor adjustments to the Tiva C Series LaunchPad. This procedure is explained in more detail later in this section.

The conditions that can generate a wake signal to the Hibernate module on the Tiva C Series LaunchPad are waking on a Real-time Clock (RTC) match and/or waking on assertion of the  $\overline{WAKE}$  pin. <sup>(1)</sup> The second user switch (SW2) is connected to the  $\overline{WAKE}$  pin on the microcontroller. The  $\overline{WAKE}$  pin, as well as the  $V_{DD}$  and  $\overline{HIB}$  pins, are easily accessible through breakout pads on the Tiva C Series LaunchPad. See the appended schematics for details.

<sup>(1)</sup> If the board does not turn on when you connect it to a power source, the microcontroller might be in Hibernate mode (depending on the programmed application). You must satisfy one of the programmed wake conditions and connect the power to bring the microcontroller out of Hibernate mode and turn on the board.

There is no external battery source on the Tiva C Series LaunchPad Hibernation module, which means the VDD3ON power control mechanism should be used. This mechanism uses internal switches to remove power from the Cortex-M4 processor as well as to most analog and digital functions while retaining I/O pin power.

To measure the Hibernation mode current or the Run mode current, the VDD jumper that connects the 3.3 V pin and the MCU\_PWR pin must be removed. See the complete schematics (appended to this document) for details on these pins and component locations. An ammeter should then be placed between the 3.3 V pin and the MCU\_PWR pin to measure  $I_{DD}$  (or  $I_{HIB\_VDD3ON}$ ). The TM4C123GH6PM microcontroller uses  $V_{DD}$  as its power source during  $V_{DD3ON}$  Hibernation mode, so  $I_{DD}$  is the Hibernation mode (VDD3ON mode) current. This measurement can also be taken during Run mode, which measures  $I_{DD}$  the microcontroller running current.

### 2.2.3 Clocking

The Tiva C Series LaunchPad uses a 16.0-MHz crystal (Y2) to complete the TM4C123GH6PM microcontroller main internal clock circuit. An internal PLL, configured in software, multiplies this clock to higher frequencies for core and peripheral timing.

The Hibernation module is clocked from an external 32.768-KHz crystal (Y1).

### 2.2.4 Reset

The  $\overline{\text{RESET}}$  signal into the TM4C123GH6PM microcontroller connects to the RESET switch and to the ICDI circuit for a debugger-controlled reset.

External reset is asserted (active low) under any of three conditions:

- Power-on reset (filtered by an R-C network)
- RESET switch held down
- By the ICDI circuit when instructed by the debugger (this capability is optional, and may not be supported by all debuggers)

## 2.3 In-Circuit Debug Interface (ICDI)

The Tiva C Series LaunchPad evaluation board comes with an on-board In-Circuit Debug Interface (ICDI). The ICDI allows for the programming and debug of the TM4C123GH6PM using the LM Flash Programmer and/or any of the supported tool chains. Note that the ICDI supports only JTAG debugging. An external debug interface can be connected for Serial Wire Debug (SWD) and SWO (trace).

Table 2-7 shows the pins used for JTAG and SWD. These signals are also mapped out to easily accessible breakout pads and headers on the board.

**Table 2-7. In-Circuit Debug Interface (ICDI) Signals**

GPIO Pin	Pin Function
PC0	TCK/SWCLK
PC1	TMS/SWDIO
PC2	TDI
PC3	TDO/SWO

### 2.3.1 Virtual COM Port

When plugged in to a PC, the device enumerates as a debugger and a virtual COM port. Table 2-8 shows the connections for the COM port to the pins on the microcontroller.

**Table 2-8. Virtual COM Port Signals**

GPIO Pin	Pin Function
PA0	U0RX
PA1	U0TX

## Software Development

---

---

This chapter provides general information on software development as well as instructions for Flash memory programming.

### 3.1 Software Description

The TivaWare software provided with the Tiva C Series LaunchPad provides access to all of the peripheral devices supplied in the design. The Tiva C Series Peripheral Driver Library is used to operate the on-chip peripherals as part of TivaWare.

TivaWare includes a set of example applications that use the TivaWare Peripheral Driver Library. These applications demonstrate the capabilities of the TM4C123GH6PM microcontroller, as well as provide a starting point for the development of the final application for use on the Tiva C Series LaunchPad evaluation board.

### 3.2 Source Code

The complete source code including the source code installation instructions are provided at [www.ti.com/tm4c123g-launchpad](http://www.ti.com/tm4c123g-launchpad). The source code and binary files are installed in the DriverLib tree.

### 3.3 Tool Options

The source code installation includes directories containing projects and/or makefiles for the following tool-chains:

- Keil ARM RealView® Microcontroller Development System
- IAR Embedded Workbench for ARM
- Sourcery CodeBench
- Texas Instruments' Code Composer Studio™ IDE

Download evaluation versions of these tools from the TI website. Due to code size restrictions, the evaluation tools may not build all example programs. A full license is necessary to re-build or debug all examples.

Instructions on installing and using each of the evaluation tools can be found in the Quickstart guides (for example, Quickstart-Keil, Quickstart-IAR) which are available for download from the evaluation kit section of the TI website at [www.ti.com/tiva-c](http://www.ti.com/tiva-c).

For detailed information on using the tools, see the documentation included in the tool chain installation or visit the respective web site of the tool supplier.

### 3.4 Programming the Tiva C Series LaunchPad Evaluation Board

The Tiva C Series LaunchPad software package includes pre-built binaries for each of the example applications. If you have installed TivaWare to the default installation path of `C:\ti\TivaWare_C_Series_<version>`, you can find the example applications in `C:\ti\TivaWare_C_Series_<version>\examples\boards\ek-tm4c123gxl`. The on-board ICDI is used with the LM Flash Programmer tool to program applications on the Tiva C Series LaunchPad.

Follow these steps to program example applications into the Tiva C Series LaunchPad evaluation board using the ICDI:

1. Install LM Flash Programmer on a PC running Microsoft® Windows®.
2. Switch the **POWER SELECT** switch to the right for Debug mode.
3. Connect the USB-A cable plug to an available port on the PC and the Micro-B plug to the **Debug USB** port on the board.
4. Verify that the POWER LED D4 on the board is lit.
5. Run the LM Flash Programmer.
6. In the Configuration tab, use the Quick Set control to select the EK-TM4C123GXL evaluation board.
7. Move to the Program tab and click the **Browse** button. Navigate to the example applications directory (the default location is `C:\ti\TivaWare_C_Series_<version>\examples\boards\ek-tm4c123gxl`).
8. Each example application has its own directory. Navigate to the example directory that you want to load and then into the directory which contains the binary (\*.bin) files. Select the binary file and click **Open**.
9. Set the **Erase Method** to *Erase Necessary Pages*, check the **Verify After Program** box, and check **Reset MCU After Program**.

Program execution starts once the Verify process is complete.

## ***References, PCB Layout, and Bill of Materials***

---

---

### **4.1 References**

In addition to this document, the following references are available for download at [www.ti.com](http://www.ti.com):

- Tiva C Series TM4C123GH6PM Microcontroller Data Sheet (literature number [SPMS376](#)).
- LM Flash Programmer tool. Available for download at [www.ti.com/tool/lmflashprogrammer](http://www.ti.com/tool/lmflashprogrammer).
- TivaWare for C Series Driver Library. Available for download at [www.ti.com/tool/sw-tm4c-drl](http://www.ti.com/tool/sw-tm4c-drl).
- TivaWare for C Series Driver Library User's Manual (literature number [SPMU298](#)).
- TPS73633 Low-Dropout Regulator with Reverse Current Protection Data Sheet (literature number [SBVS038](#))
- Texas Instruments' Code Composer Studio IDE website: [www.ti.com/ccs](http://www.ti.com/ccs)

Additional support:

- RealView MDK ([www.keil.com/arm/rvmdkkit.asp](http://www.keil.com/arm/rvmdkkit.asp))
- IAR Embedded Workbench ([www.iar.com](http://www.iar.com)).
- Sourcery CodeBench development tools ([www.codesourcery.com/gnu\\_toolchains/arm](http://www.codesourcery.com/gnu_toolchains/arm)).

## 4.2 Component Locations

Plots of the top-side component locations are shown in [Figure 4-1](#) and the board dimensions are shown in [Figure 4-2](#).

**Figure 4-1. Tiva C Series LaunchPad Component Locations (Top View)**

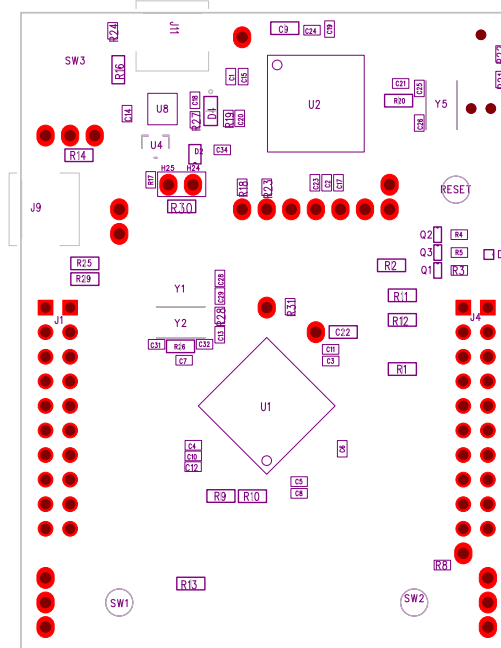



**Figure 4-2. Tiva C Series LaunchPad Dimensions**

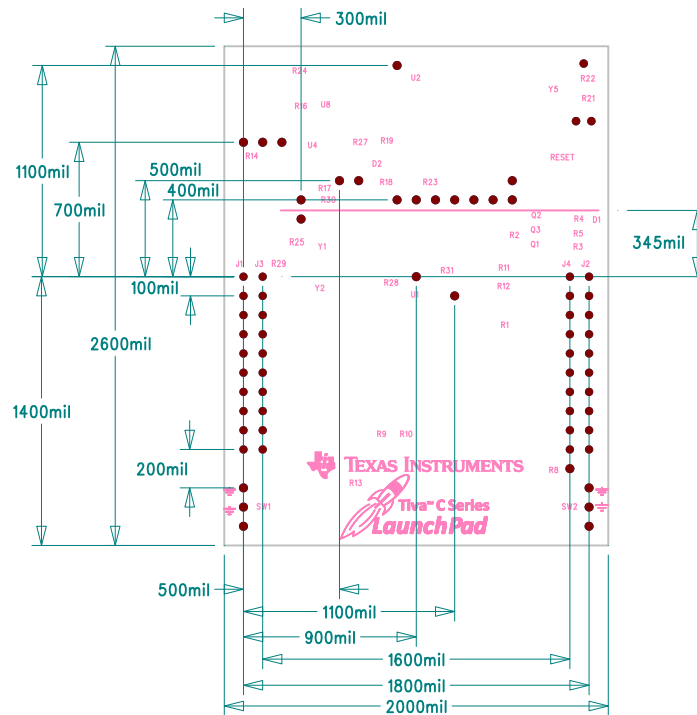

**NOTE:** Units are in mils (one thousandth of an inch): 1 mil = 0.001 inch (0.0254 mm).

### 4.3 Bill of Materials (BOM)

Table 4-1 shows the bill of materials for the EK-TM4C123GXL evaluation board.

**Table 4-1. EK-TM4C123GXL Bill of Materials**

Item	Ref Des	Qty	Description	Manufacturer	Manufacturer Part No
1	C1-2, C7, C12, C14	5	Capacitor, 0402, X5R, 10 V, Low ESR	Johanson Dielectrics Inc	100R07X105KV4T
2	C25-26, C31-32	4	Capacitor, 10 pF, 50 V, 5%, NPO/COG, 0402	Murata	GRM1555C1H100JZ01D
3	C28-29	2	Capacitor, 24 pF, 50 V, 5%, NPO/COG, 0402	TDK	C1005C0G1H240J
4	C3, C5, C8, C15, C18-19, C21	7	Capacitor, 0.01 µF 25 V, 10% 0402 X7R	Taiyo Yuden	TMK105B7103KV-F
5	C4, C6, C10-11, C17, C20, C23-24	8	Capacitor, 0.1 µF 16 V, 10% 0402 X7R	Taiyo Yuden	EMK105B7104KV-F
6	C9, C22	2	Capacitor, 2.2 µF, 16 V, 10%, 0603, X5R	Murata	GRM188R61C225KE15D
7	D1	1	LED, Tri-Color RGB, 0404 SMD Common Anode	Everlight	18-038/RSGHBHC1-S02/2T
8	D4	1	LED, Green 565 nm, Clear 0805 SMD	Lite-On	LTST-C171GKT
9	H24	1	Header, 1x2, 0.100, T-Hole, Vertical Unshrouded, 0.220 Mate	3M FCI	961102-6404-AR 68001-102HLF
10	H25	1	Jumper, 0.100, Gold, Black, Closed	Sullins	SPC02SYAN
11	J1, J3	2	Header, 2x10, T-Hole Vertical unshrouded stacking	Samtec	SSW-110-23-S-D

**Table 4-1. EK-TM4C123GXL Bill of Materials (continued)**

Item	Ref Des	Qty	Description	Manufacturer	Manufacturer Part No
12	J11	1	USB Connector, Micro B Recept RA SMT BTTM MNT	Hirose	ZX62-B-5PA
13	J2, J4	2	Header, 1x2, 0.100, SMT, Horizontal Unshrouded, 0.230 Mate	Samtec	TSM-110-01-S-DH-A-P-TR
				4UCON	10995
				Major League Electronics	TSHSM-110-D-02-T-H-AP- TR-P-LF
14	J9	1	USB Connector, Micro A/B Receptacle SMD	Hirose	ZX62-AB-5PA
15	Q1-3	3	NPN SC70 pre-biased	Diodes Inc	DTC114EET1G
16	R1-2, R9-16, R20, R26	12	Resistor, 0 $\Omega$ 1/10W 0603 SMD	Panasonic	ERJ-3GEY0R00V
17	R18-19, R21-23, R28	6	Resistor, 10 k $\Omega$ , 1/10W, 5%, 0402 Thick Film	Yageo	RC0402FR-0710KL
18	R3-5, R8, R27	5	Resistor, 330 $\Omega$ , 1/10W, 5%, 0402	Yageo	RC0402FR-07330RL
19	R31	1	Resistor, 1 M $\Omega$ 1/10W, 5%, 0402	Rohm	MCR01MRTF1004
20	RESET SW1, SW2	3	Switch, Tact 6 mm SMT, 160gf	Omron	B3S-1000
21	SW3	1	Switch, DPDT, SMT 300 mA x 2 at 6 V	C K Components	JS202011SCQN
22	U1, U2	2	Tiva C Series MCU TM4C123GH6PM	Texas Instruments	TM4C123GH6PMI
23	U8	1	Regulator, 3.3 V, 400 mA, LDO	Texas Instruments	TPS73633DRBT
24	Y1	1	Crystal, 32.768 kHz Radial Can	Abracon	AB26TRB-32.768KHZ- T
25	Y2, Y5	2	Crystal, 16.00 MHz 5.0x3.2mm SMT	NDK	NX5032GA-16.000000 MHz
				Abracon	ABM3-16.000 MHz-B2- T
PCB Do Not Populate List (Shown for information only)					
26	C31, C34	2	Capacitor, 0.1 $\mu$ F 16 V, 10% 0402 X7R	Taiyo Yuden	EMK105B7104KV-F
27	D2	1	Diode, Dual Schottky, SC70, BAS70 Common Cathode	Diodes Inc	BAS70W-05-7-F
28	R17	1	Resistor, 10 k $\Omega$ 1/10W 5%, 0402 Thick Film	Yageo	RC0402FR-0710KL
29	R24	1	Resistor, 330 $\Omega$ , 1/10W, 5%, 0402	Yageo	RC0402FR-07330RL
30	R25, R29-30	3	Resistor, 0 $\Omega$ , 1/10W 0603	Panasonic	ERJ-3GEY0R00V
31	U4	1	IC, Single Voltage Supervisor, 5V, DBV	Texas Instruments	TLV803MDBZR

## ***Schematics***

---

---

---

This section contains the complete schematics for the Tiva C Series LaunchPad board.

- Microcontroller, USB, Expansion, Buttons, and LED
- Power Management
- In-Circuit Debug Interface

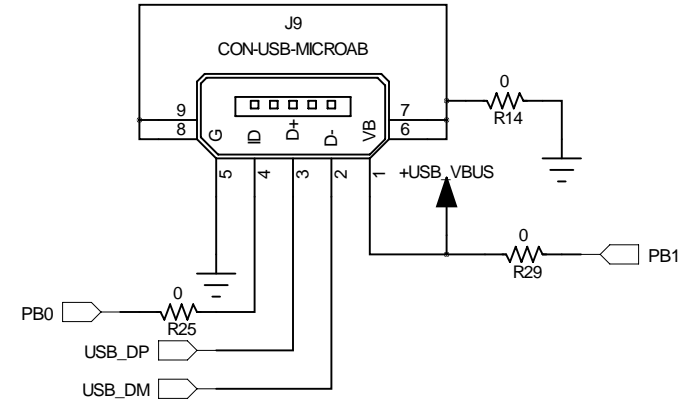
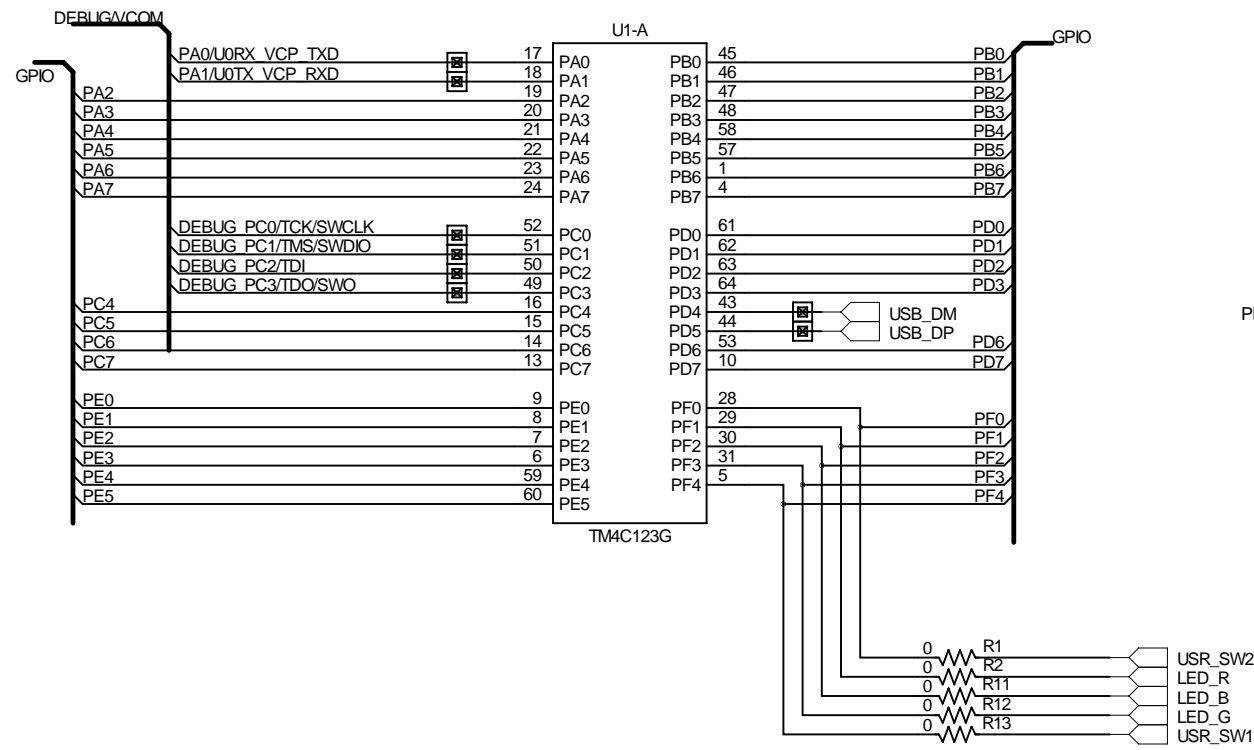

J1 and J2 provide compatibility with Booster Packs designed for MSP430 Launchpad  
 J3 and J4 sit 100 mils inside J1 and J2 to provide extended functions specific to this board.  
 See the board user manual for complete table of pin mux functions

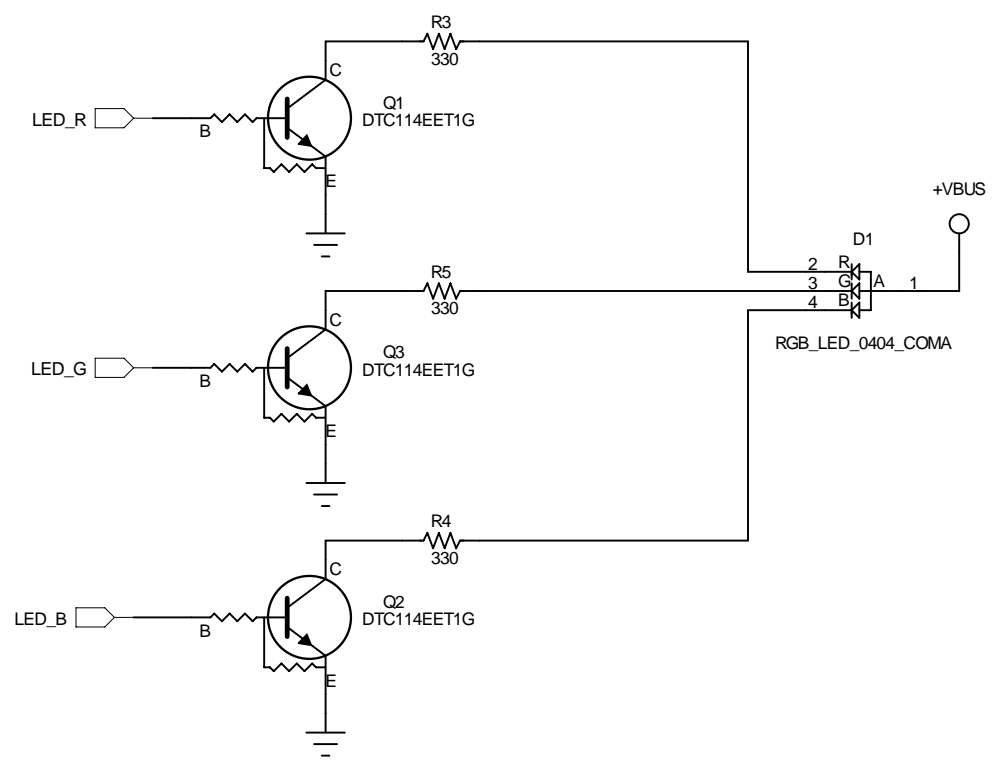
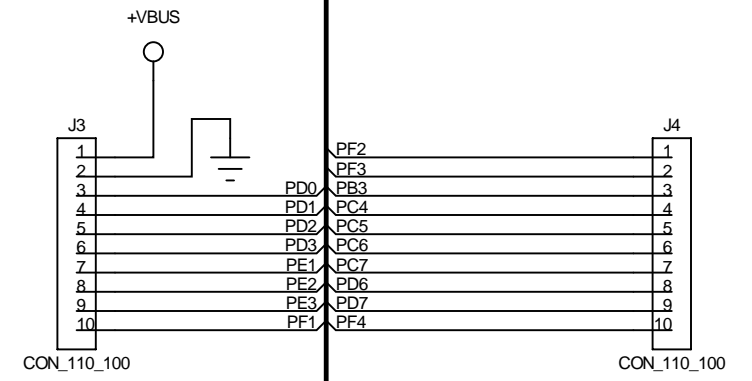
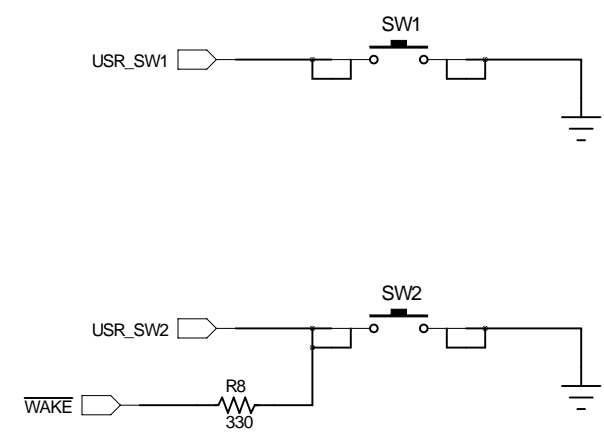
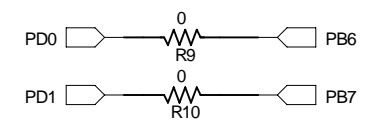
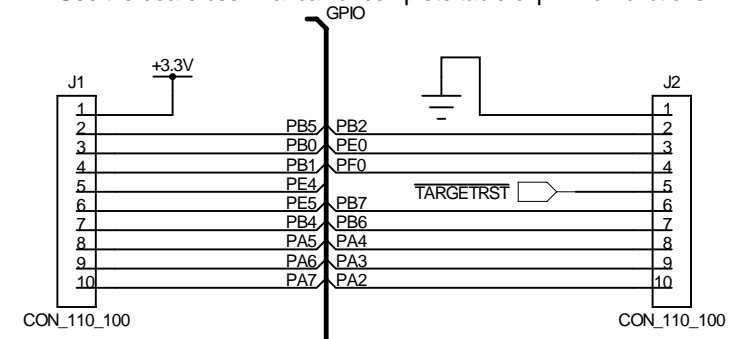

DESIGNER DGT	REVISION 0.3	DATE 2/20/2013
PROJECT Tiva TM4C123G LaunchPad		
DESCRIPTION Microcontroller, USB, Expansion, Buttons and LED		
FILENAME EK-TM4C123GXL Rev A.sch		

**TEXAS INSTRUMENTS**

TIVA MICROCONTROLLERS  
 108 WILD BASIN ROAD, SUITE 350  
 AUSTIN TX, 78746  
 www.ti.com

PART NO. EK-TM4C123GXL	SHEET 1 OF 3
---------------------------	-----------------

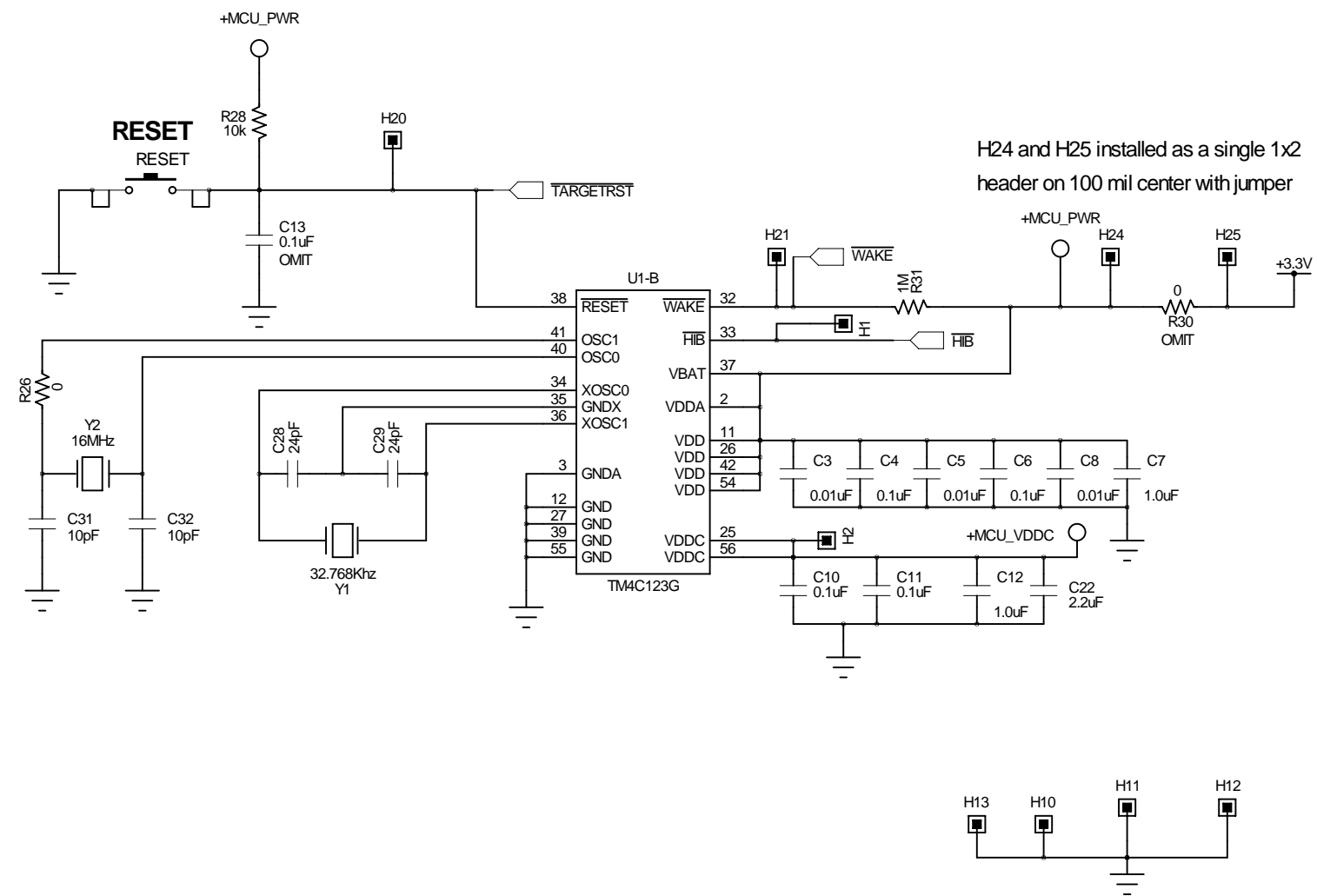
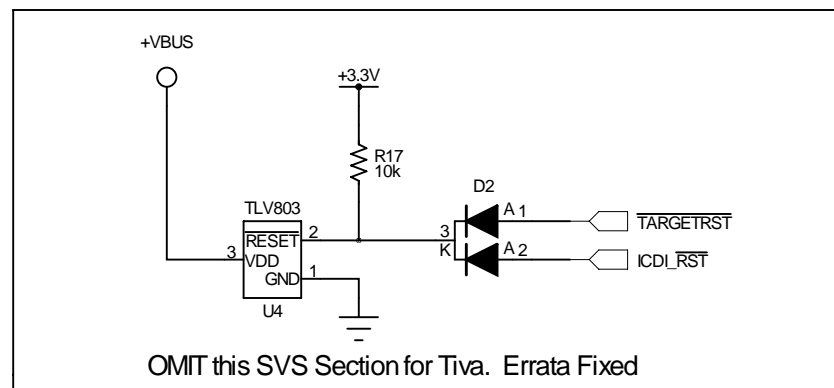
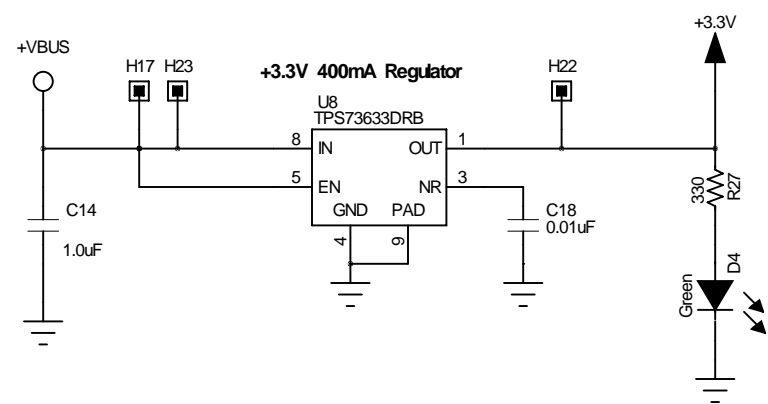
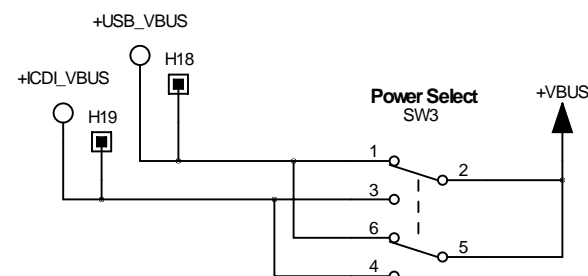

DESIGNER DGT	REVISION 0.3	DATE 2/20/2013
PROJECT Tiva Launchpad		
DESCRIPTION Power Management		
FILENAME EK-TM4C123GXL Rev A.sch		

	<b>TEXAS INSTRUMENTS</b> TIVA MICROCONTROLLERS 108 WILD BASIN ROAD, SUITE 350 AUSTIN TX, 78746 www.ti.com	
	PART NO. EK-TM4C123GXL	SHEET 2 OF 3

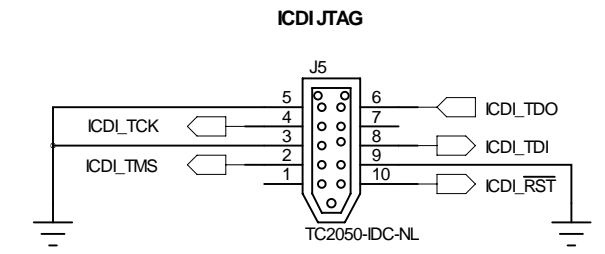
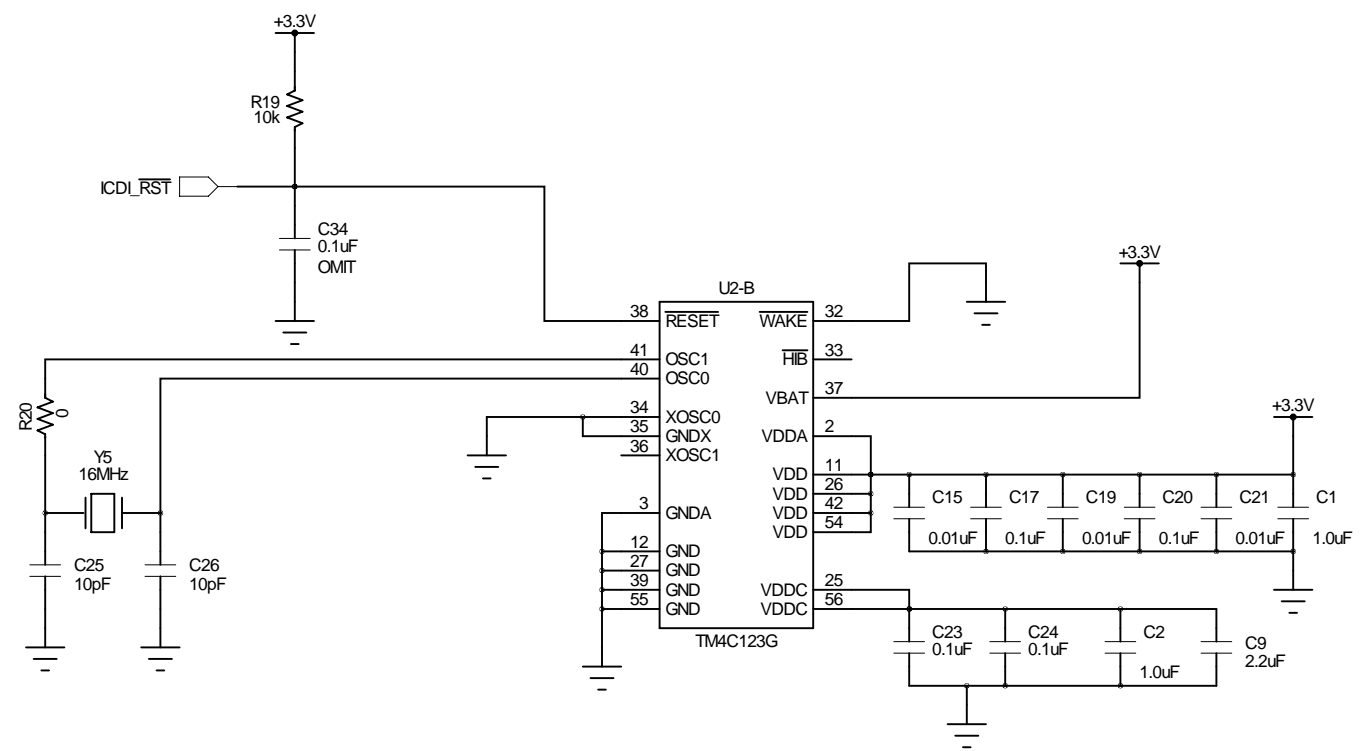
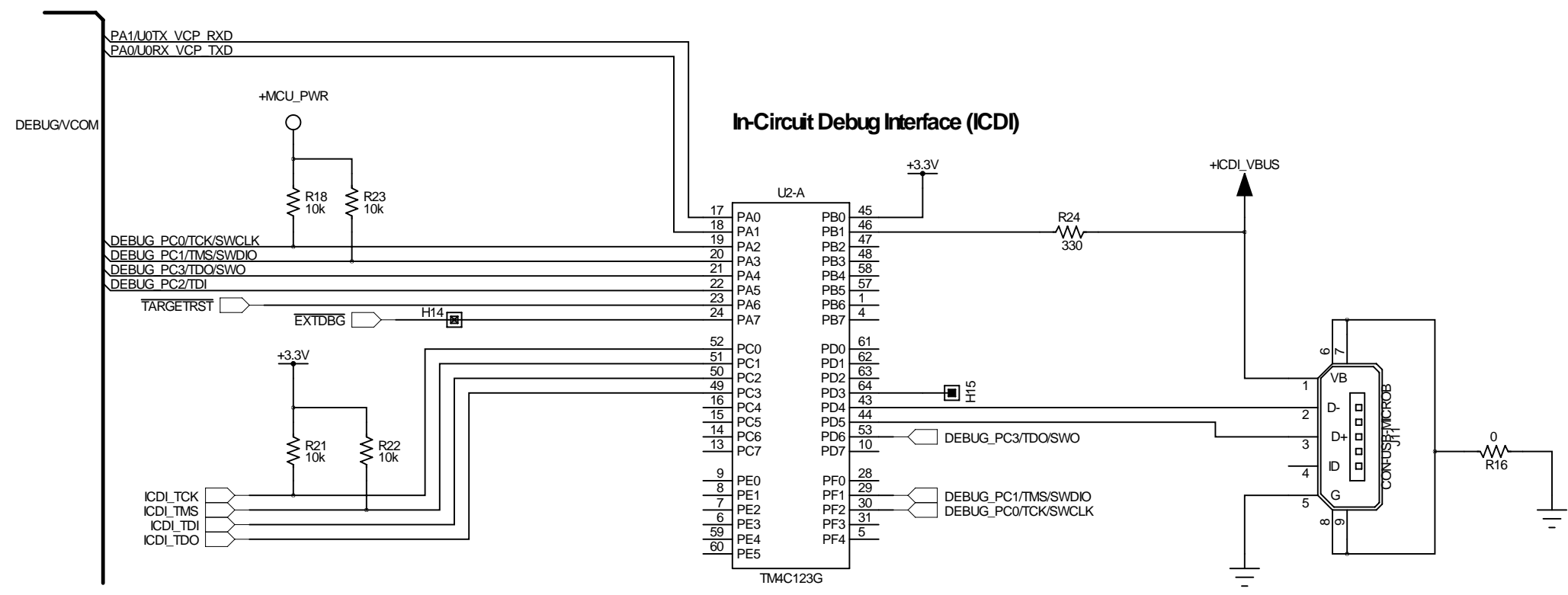

DESIGNER DGT	REVISION 0.3	DATE 2/20/2013
PROJECT Tiva TM4C123G LaunchPad		
DESCRIPTION In Circuit Debug Interface		
FILENAME EK-TM4C123GXL Rev A.sch		
PART NO. EK-TM4C123GXL		SHEET 3 OF 3

**TEXAS INSTRUMENTS**  
 TIVA MICROCONTROLLERS  
 108 WILD BASIN ROAD, SUITE 350  
 AUSTIN TX, 78746  
 www.ti.com

## EVALUATION BOARD/KIT/MODULE (EVM) ADDITIONAL TERMS

Texas Instruments (TI) provides the enclosed Evaluation Board/Kit/Module (EVM) under the following conditions:

The user assumes all responsibility and liability for proper and safe handling of the goods. Further, the user indemnifies TI from all claims arising from the handling or use of the goods.

Should this evaluation board/kit not meet the specifications indicated in the User's Guide, the board/kit may be returned within 30 days from the date of delivery for a full refund. THE FOREGOING LIMITED WARRANTY IS THE EXCLUSIVE WARRANTY MADE BY SELLER TO BUYER AND IS IN LIEU OF ALL OTHER WARRANTIES, EXPRESSED, IMPLIED, OR STATUTORY, INCLUDING ANY WARRANTY OF MERCHANTABILITY OR FITNESS FOR ANY PARTICULAR PURPOSE. EXCEPT TO THE EXTENT OF THE INDEMNITY SET FORTH ABOVE, NEITHER PARTY SHALL BE LIABLE TO THE OTHER FOR ANY INDIRECT, SPECIAL, INCIDENTAL, OR CONSEQUENTIAL DAMAGES.

Please read the User's Guide and, specifically, the Warnings and Restrictions notice in the User's Guide prior to handling the product. This notice contains important safety information about temperatures and voltages. For additional information on TI's environmental and/or safety programs, please visit [www.ti.com/esh](http://www.ti.com/esh) or contact TI.

No license is granted under any patent right or other intellectual property right of TI covering or relating to any machine, process, or combination in which such TI products or services might be or are used. TI currently deals with a variety of customers for products, and therefore our arrangement with the user is not exclusive. TI assumes no liability for applications assistance, customer product design, software performance, or infringement of patents or services described herein.

## REGULATORY COMPLIANCE INFORMATION

As noted in the EVM User's Guide and/or EVM itself, this EVM and/or accompanying hardware may or may not be subject to the Federal Communications Commission (FCC) and Industry Canada (IC) rules.

For EVMs **not** subject to the above rules, this evaluation board/kit/module is intended for use for ENGINEERING DEVELOPMENT, DEMONSTRATION OR EVALUATION PURPOSES ONLY and is not considered by TI to be a finished end product fit for general consumer use. It generates, uses, and can radiate radio frequency energy and has not been tested for compliance with the limits of computing devices pursuant to part 15 of FCC or ICES-003 rules, which are designed to provide reasonable protection against radio frequency interference. Operation of the equipment may cause interference with radio communications, in which case the user at his own expense will be required to take whatever measures may be required to correct this interference.

### **General Statement for EVMs including a radio**

*User Power/Frequency Use Obligations:* This radio is intended for development/professional use only in legally allocated frequency and power limits. Any use of radio frequencies and/or power availability of this EVM and its development application(s) must comply with local laws governing radio spectrum allocation and power limits for this evaluation module. It is the user's sole responsibility to only operate this radio in legally acceptable frequency space and within legally mandated power limitations. Any exceptions to this are strictly prohibited and unauthorized by Texas Instruments unless user has obtained appropriate experimental/development licenses from local regulatory authorities, which is responsibility of user including its acceptable authorization.

### **For EVMs annotated as FCC – FEDERAL COMMUNICATIONS COMMISSION Part 15 Compliant**

#### **Caution**

This device complies with part 15 of the FCC Rules. Operation is subject to the following two conditions: (1) This device may not cause harmful interference, and (2) this device must accept any interference received, including interference that may cause undesired operation.

Changes or modifications not expressly approved by the party responsible for compliance could void the user's authority to operate the equipment.

#### **FCC Interference Statement for Class A EVM devices**

This equipment has been tested and found to comply with the limits for a Class A digital device, pursuant to part 15 of the FCC Rules. These limits are designed to provide reasonable protection against harmful interference when the equipment is operated in a commercial environment. This equipment generates, uses, and can radiate radio frequency energy and, if not installed and used in accordance with the instruction manual, may cause harmful interference to radio communications. Operation of this equipment in a residential area is likely to cause harmful interference in which case the user will be required to correct the interference at his own expense.

### **FCC Interference Statement for Class B EVM devices**

This equipment has been tested and found to comply with the limits for a Class B digital device, pursuant to part 15 of the FCC Rules. These limits are designed to provide reasonable protection against harmful interference in a residential installation. This equipment generates, uses and can radiate radio frequency energy and, if not installed and used in accordance with the instructions, may cause harmful interference to radio communications. However, there is no guarantee that interference will not occur in a particular installation. If this equipment does cause harmful interference to radio or television reception, which can be determined by turning the equipment off and on, the user is encouraged to try to correct the interference by one or more of the following measures:

- Reorient or relocate the receiving antenna.
- Increase the separation between the equipment and receiver.
- Connect the equipment into an outlet on a circuit different from that to which the receiver is connected.
- Consult the dealer or an experienced radio/TV technician for help.

### **For EVMs annotated as IC – INDUSTRY CANADA Compliant**

This Class A or B digital apparatus complies with Canadian ICES-003.

Changes or modifications not expressly approved by the party responsible for compliance could void the user's authority to operate the equipment.

### **Concerning EVMs including radio transmitters**

This device complies with Industry Canada licence-exempt RSS standard(s). Operation is subject to the following two conditions: (1) this device may not cause interference, and (2) this device must accept any interference, including interference that may cause undesired operation of the device.

### **Concerning EVMs including detachable antennas**

Under Industry Canada regulations, this radio transmitter may only operate using an antenna of a type and maximum (or lesser) gain approved for the transmitter by Industry Canada. To reduce potential radio interference to other users, the antenna type and its gain should be so chosen that the equivalent isotropically radiated power (e.i.r.p.) is not more than that necessary for successful communication.

This radio transmitter has been approved by Industry Canada to operate with the antenna types listed in the user guide with the maximum permissible gain and required antenna impedance for each antenna type indicated. Antenna types not included in this list, having a gain greater than the maximum gain indicated for that type, are strictly prohibited for use with this device.

Cet appareil numérique de la classe A ou B est conforme à la norme NMB-003 du Canada.

Les changements ou les modifications pas expressément approuvés par la partie responsable de la conformité ont pu vider l'autorité de l'utilisateur pour actionner l'équipement.

### **Concernant les EVMs avec appareils radio**

Le présent appareil est conforme aux CNR d'Industrie Canada applicables aux appareils radio exempts de licence. L'exploitation est autorisée aux deux conditions suivantes : (1) l'appareil ne doit pas produire de brouillage, et (2) l'utilisateur de l'appareil doit accepter tout brouillage radioélectrique subi, même si le brouillage est susceptible d'en compromettre le fonctionnement.

### **Concernant les EVMs avec antennes détachables**

Conformément à la réglementation d'Industrie Canada, le présent émetteur radio peut fonctionner avec une antenne d'un type et d'un gain maximal (ou inférieur) approuvé pour l'émetteur par Industrie Canada. Dans le but de réduire les risques de brouillage radioélectrique à l'intention des autres utilisateurs, il faut choisir le type d'antenne et son gain de sorte que la puissance isotrope rayonnée équivalente (p.i.r.e.) ne dépasse pas l'intensité nécessaire à l'établissement d'une communication satisfaisante.

Le présent émetteur radio a été approuvé par Industrie Canada pour fonctionner avec les types d'antenne énumérés dans le manuel d'usage et ayant un gain admissible maximal et l'impédance requise pour chaque type d'antenne. Les types d'antenne non inclus dans cette liste, ou dont le gain est supérieur au gain maximal indiqué, sont strictement interdits pour l'exploitation de l'émetteur.



## **【Important Notice for Users of this Product in Japan】**

### **This development kit is NOT certified as Confirming to Technical Regulations of Radio Law of Japan**

If you use this product in Japan, you are required by Radio Law of Japan to follow the instructions below with respect to this product:

1. Use this product in a shielded room or any other test facility as defined in the notification #173 issued by Ministry of Internal Affairs and Communications on March 28, 2006, based on Sub-section 1.1 of Article 6 of the Ministry's Rule for Enforcement of Radio Law of Japan,
2. Use this product only after you obtained the license of Test Radio Station as provided in Radio Law of Japan with respect to this product, or
3. Use of this product only after you obtained the Technical Regulations Conformity Certification as provided in Radio Law of Japan with respect to this product. Also, please do not transfer this product, unless you give the same notice above to the transferee. Please note that if you could not follow the instructions above, you will be subject to penalties of Radio Law of Japan.

**Texas Instruments Japan Limited**  
**(address) 24-1, Nishi-Shinjuku 6 chome, Shinjuku-ku, Tokyo, Japan**

<http://www.tij.co.jp>

#### **【ご使用にあたっての注】**

本開発キットは技術基準適合証明を受けておりません。

本製品のご使用に際しては、電波法遵守のため、以下のいずれかの措置を取っていただく必要がありますのでご注意ください。

1. 電波法施行規則第6条第1項第1号に基づく平成18年3月28日総務省告示第173号で定められた電波暗室等の試験設備でご使用いただく。
2. 実験局の免許を取得後ご使用いただく。
3. 技術基準適合証明を取得後ご使用いただく。

なお、本製品は、上記の「ご使用にあたっての注意」を譲渡先、移転先に通知しない限り、譲渡、移転できないものとします。

上記を遵守頂けない場合は、電波法の罰則が適用される可能性があることをご留意ください。

日本テキサス・インスツルメンツ株式会社  
東京都新宿区西新宿6丁目24番1号  
西新宿三井ビル

<http://www.tij.co.jp>

## **EVALUATION BOARD/KIT/MODULE (EVM) WARNINGS, RESTRICTIONS AND DISCLAIMERS**

**For Feasibility Evaluation Only, in Laboratory/Development Environments.** Unless otherwise indicated, this EVM is not a finished electrical equipment and not intended for consumer use. It is intended solely for use for preliminary feasibility evaluation in laboratory/development environments by technically qualified electronics experts who are familiar with the dangers and application risks associated with handling electrical mechanical components, systems and subsystems. It should not be used as all or part of a finished end product.

Your Sole Responsibility and Risk. You acknowledge, represent and agree that:

1. You have unique knowledge concerning Federal, State and local regulatory requirements (including but not limited to Food and Drug Administration regulations, if applicable) which relate to your products and which relate to your use (and/or that of your employees, affiliates, contractors or designees) of the EVM for evaluation, testing and other purposes.
2. You have full and exclusive responsibility to assure the safety and compliance of your products with all such laws and other applicable regulatory requirements, and also to assure the safety of any activities to be conducted by you and/or your employees, affiliates, contractors or designees, using the EVM. Further, you are responsible to assure that any interfaces (electronic and/or mechanical) between the EVM and any human body are designed with suitable isolation and means to safely limit accessible leakage currents to minimize the risk of electrical shock hazard.
3. You will employ reasonable safeguards to ensure that your use of the EVM will not result in any property damage, injury or death, even if the EVM should fail to perform as described or expected.
4. You will take care of proper disposal and recycling of the EVM's electronic components and packing materials.

**Certain Instructions.** It is important to operate this EVM within TI's recommended specifications and environmental considerations per the user guidelines. Exceeding the specified EVM ratings (including but not limited to input and output voltage, current, power, and environmental ranges) may cause property damage, personal injury or death. If there are questions concerning these ratings please contact a TI field representative prior to connecting interface electronics including input power and intended loads. Any loads applied outside of the specified output range may result in unintended and/or inaccurate operation and/or possible permanent damage to the EVM and/or interface electronics. Please consult the EVM User's Guide prior to connecting any load to the EVM output. If there is uncertainty as to the load specification, please contact a TI field representative. During normal operation, some circuit components may have case temperatures greater than 60°C as long as the input and output are maintained at a normal ambient operating temperature. These components include but are not limited to linear regulators, switching transistors, pass transistors, and current sense resistors which can be identified using the EVM schematic located in the EVM User's Guide. When placing measurement probes near these devices during normal operation, please be aware that these devices may be very warm to the touch. As with all electronic evaluation tools, only qualified personnel knowledgeable in electronic measurement and diagnostics normally found in development environments should use these EVMs.

**Agreement to Defend, Indemnify and Hold Harmless.** You agree to defend, indemnify and hold TI, its licensors and their representatives harmless from and against any and all claims, damages, losses, expenses, costs and liabilities (collectively, "Claims") arising out of or in connection with any use of the EVM that is not in accordance with the terms of the agreement. This obligation shall apply whether Claims arise under law of tort or contract or any other legal theory, and even if the EVM fails to perform as described or expected.

**Safety-Critical or Life-Critical Applications.** If you intend to evaluate the components for possible use in safety critical applications (such as life support) where a failure of the TI product would reasonably be expected to cause severe personal injury or death, such as devices which are classified as FDA Class III or similar classification, then you must specifically notify TI of such intent and enter into a separate Assurance and Indemnity Agreement.

Mailing Address: Texas Instruments, Post Office Box 655303, Dallas, Texas 75265  
Copyright © 2013, Texas Instruments Incorporated

## IMPORTANT NOTICE

Texas Instruments Incorporated and its subsidiaries (TI) reserve the right to make corrections, enhancements, improvements and other changes to its semiconductor products and services per JESD46, latest issue, and to discontinue any product or service per JESD48, latest issue. Buyers should obtain the latest relevant information before placing orders and should verify that such information is current and complete. All semiconductor products (also referred to herein as "components") are sold subject to TI's terms and conditions of sale supplied at the time of order acknowledgment.

TI warrants performance of its components to the specifications applicable at the time of sale, in accordance with the warranty in TI's terms and conditions of sale of semiconductor products. Testing and other quality control techniques are used to the extent TI deems necessary to support this warranty. Except where mandated by applicable law, testing of all parameters of each component is not necessarily performed.

TI assumes no liability for applications assistance or the design of Buyers' products. Buyers are responsible for their products and applications using TI components. To minimize the risks associated with Buyers' products and applications, Buyers should provide adequate design and operating safeguards.

TI does not warrant or represent that any license, either express or implied, is granted under any patent right, copyright, mask work right, or other intellectual property right relating to any combination, machine, or process in which TI components or services are used. Information published by TI regarding third-party products or services does not constitute a license to use such products or services or a warranty or endorsement thereof. Use of such information may require a license from a third party under the patents or other intellectual property of the third party, or a license from TI under the patents or other intellectual property of TI.

Reproduction of significant portions of TI information in TI data books or data sheets is permissible only if reproduction is without alteration and is accompanied by all associated warranties, conditions, limitations, and notices. TI is not responsible or liable for such altered documentation. Information of third parties may be subject to additional restrictions.

Resale of TI components or services with statements different from or beyond the parameters stated by TI for that component or service voids all express and any implied warranties for the associated TI component or service and is an unfair and deceptive business practice. TI is not responsible or liable for any such statements.

Buyer acknowledges and agrees that it is solely responsible for compliance with all legal, regulatory and safety-related requirements concerning its products, and any use of TI components in its applications, notwithstanding any applications-related information or support that may be provided by TI. Buyer represents and agrees that it has all the necessary expertise to create and implement safeguards which anticipate dangerous consequences of failures, monitor failures and their consequences, lessen the likelihood of failures that might cause harm and take appropriate remedial actions. Buyer will fully indemnify TI and its representatives against any damages arising out of the use of any TI components in safety-critical applications.

In some cases, TI components may be promoted specifically to facilitate safety-related applications. With such components, TI's goal is to help enable customers to design and create their own end-product solutions that meet applicable functional safety standards and requirements. Nonetheless, such components are subject to these terms.

No TI components are authorized for use in FDA Class III (or similar life-critical medical equipment) unless authorized officers of the parties have executed a special agreement specifically governing such use.

Only those TI components which TI has specifically designated as military grade or "enhanced plastic" are designed and intended for use in military/aerospace applications or environments. Buyer acknowledges and agrees that any military or aerospace use of TI components which have **not** been so designated is solely at the Buyer's risk, and that Buyer is solely responsible for compliance with all legal and regulatory requirements in connection with such use.

TI has specifically designated certain components as meeting ISO/TS16949 requirements, mainly for automotive use. In any case of use of non-designated products, TI will not be responsible for any failure to meet ISO/TS16949.

### Products

Audio	<a href="http://www.ti.com/audio">www.ti.com/audio</a>
Amplifiers	<a href="http://amplifier.ti.com">amplifier.ti.com</a>
Data Converters	<a href="http://dataconverter.ti.com">dataconverter.ti.com</a>
DLP® Products	<a href="http://www.dlp.com">www.dlp.com</a>
DSP	<a href="http://dsp.ti.com">dsp.ti.com</a>
Clocks and Timers	<a href="http://www.ti.com/clocks">www.ti.com/clocks</a>
Interface	<a href="http://interface.ti.com">interface.ti.com</a>
Logic	<a href="http://logic.ti.com">logic.ti.com</a>
Power Mgmt	<a href="http://power.ti.com">power.ti.com</a>
Microcontrollers	<a href="http://microcontroller.ti.com">microcontroller.ti.com</a>
RFID	<a href="http://www.ti-rfid.com">www.ti-rfid.com</a>
OMAP Applications Processors	<a href="http://www.ti.com/omap">www.ti.com/omap</a>
Wireless Connectivity	<a href="http://www.ti.com/wirelessconnectivity">www.ti.com/wirelessconnectivity</a>

### Applications

Automotive and Transportation	<a href="http://www.ti.com/automotive">www.ti.com/automotive</a>
Communications and Telecom	<a href="http://www.ti.com/communications">www.ti.com/communications</a>
Computers and Peripherals	<a href="http://www.ti.com/computers">www.ti.com/computers</a>
Consumer Electronics	<a href="http://www.ti.com/consumer-apps">www.ti.com/consumer-apps</a>
Energy and Lighting	<a href="http://www.ti.com/energy">www.ti.com/energy</a>
Industrial	<a href="http://www.ti.com/industrial">www.ti.com/industrial</a>
Medical	<a href="http://www.ti.com/medical">www.ti.com/medical</a>
Security	<a href="http://www.ti.com/security">www.ti.com/security</a>
Space, Avionics and Defense	<a href="http://www.ti.com/space-avionics-defense">www.ti.com/space-avionics-defense</a>
Video and Imaging	<a href="http://www.ti.com/video">www.ti.com/video</a>

### TI E2E Community

[e2e.ti.com](http://e2e.ti.com)