

Double Micro Relay K



Description

Features

- Smallest twin relay
- Minimal weight (0.28 oz. / 8 g)
- Maximum continuous current 30 A
- Two separate systems
- ELV/RoHS/WEEE compliant

Typical applications

- Rear window and seat heating
- Wiper and indicator control
- Motor management

Please contact Tyco Electronics for relay application support.

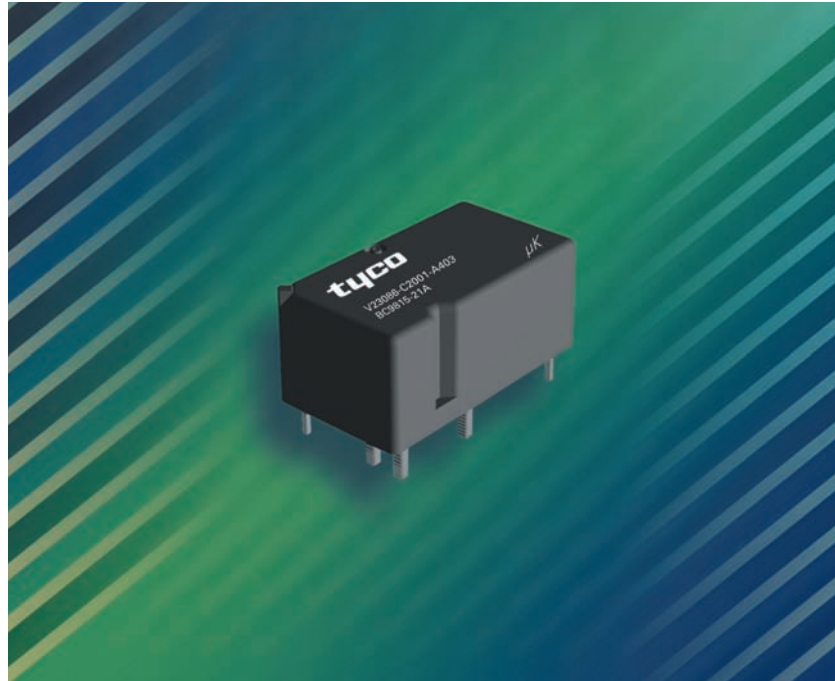

~~Car Industry~~



~~Truck Industry~~



~~Other Industry~~

86_3d01

Design

Sealed;
sealed version:
sealing in accordance with IEC 68;
immersion cleanable:
protection class IP67 to IEC 529 (EN 60 529)

Weight

Approx. 0.28 oz. (8 g)

Nominal voltage

10 V, 12 V
other nominal voltages on request

Terminals

PCB terminals, for assembling in printed circuit boards

Conditions

All parametric, environmental and endurance tests are performed according to EIA Standard RS-407-A at standard test conditions unless otherwise noted:
23 °C ambient temperature,
20-50% RH, 29.5 ± 1.0" Hg (998.9 ± 33.9 hPa).

For general precautions please refer to our Application Notes and especially to *Storage* in the "Glossary" at <http://relays.tycoelectronics.com/appnotes/>

Disclaimer

All technical performance data apply to the relay as such, specific conditions of the individual application are not considered. Please always check the suitability of the relay for your intended purpose. We do not assume any responsibility or liability for not complying herewith. We recommend to complete our questionnaire and to request our technical service. Any responsibility for the application of the product remains with the customer only. All specifications are subject to change without notification. All rights of Tyco are reserved.

Double Micro Relay K

Dimensional drawing

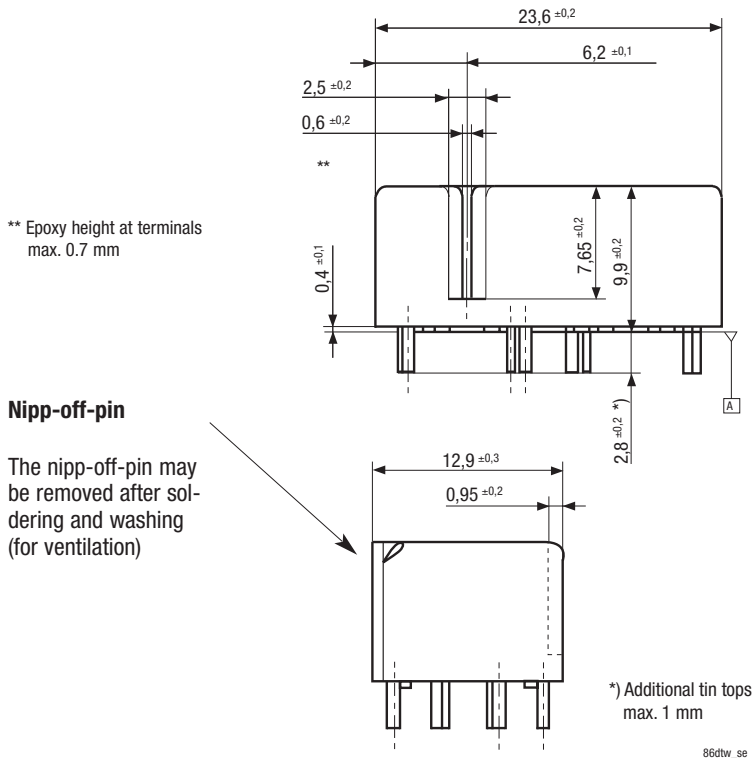

Mounting

View of the terminals (Bottom view)

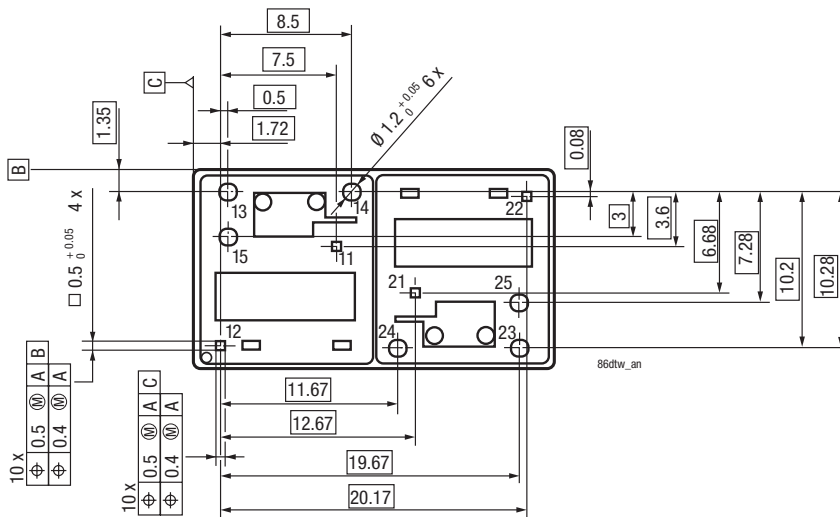

Remark: Positional tolerances according to DIN EN ISO 5458

Double Micro Relay K

Contact data

Typical areas of application	Resistive/inductive load		
Contact configuration	2 changeover contacts/ 2 form C		
Circuit symbol (see also Pin assignment)			
Rated voltage	12 V		
Rated current at 85 °C	NC/NO 15 A/20 A		
Contact material	AgSnO ₂		
Max. switching voltage/power	See load limit curve		
Max. switching current ¹⁾	NC/NO		
On ²⁾	40 A		
Off	30 A		
Min. recommended load ³⁾	1 A at 5 V		
Voltage drop at 10 A (initial) for NC/NO contacts	Typ. 30 mV, 300 mV max.		
Mechanical endurance (without load)	> 5 x 10 ⁶ operations		
Electrical endurance at cyclic temperature -40 /+23 /+85 °C and 13.5 V	Resistive load: > 3 x 10 ⁵ operations 20 A on NO-contact	Wiper reverse ⁴⁾ : > 3 x 10 ⁵ operations 25 A make/5 A break; generator peak - 10 A L= 1.0 mH	Motor reverse blocked: > 1 x 10 ⁵ operations 25 A L= 0.77 mH

¹⁾ The values apply to a resistive or inductive load with suitable spark suppression and at maximum 13.5 V for 12 V load voltages.

²⁾ For a load current duration of maximum 3 s for a make/break ratio of 1:10.

³⁾ See Diagnostic Routines in our Application Notes at <http://relays.tycoelectronics.com/appnotes/>

⁴⁾ Avoid using capacitive protection circuits. It will reduce lifetime.

Load limit curve

086LLC07

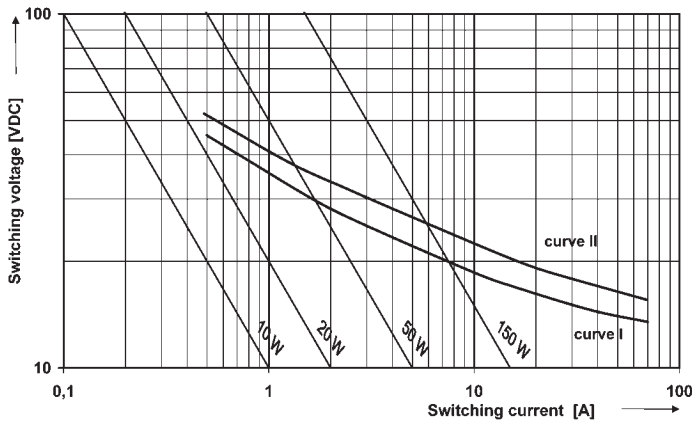

Pin assignment

2 changeover contacts/
2 form C

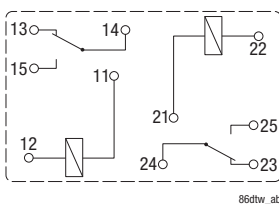

86dtw_ab

Double Micro Relay K

Coil data

Available for nominal voltages	10, 12 V
Nominal power consumption of the unsuppressed coil at nominal voltage	0.57 W
Test voltage winding/contact	500 VAC _{rms}
Maximum ambient temperature range ¹⁾	- 40 to + 105 °C
Operate time at nominal voltage	Typ. 3 ms
Release time at nominal voltage ²⁾	Typ. 1.5 ms

¹⁾ See also operating voltage range diagram

²⁾ For unsuppressed relay coil

N.B.

A low resistive suppression device in parallel to the relay coil increases the release time and reduces the lifetime caused by increased erosion and/or higher risk of contact tack welding.

Operating voltage range

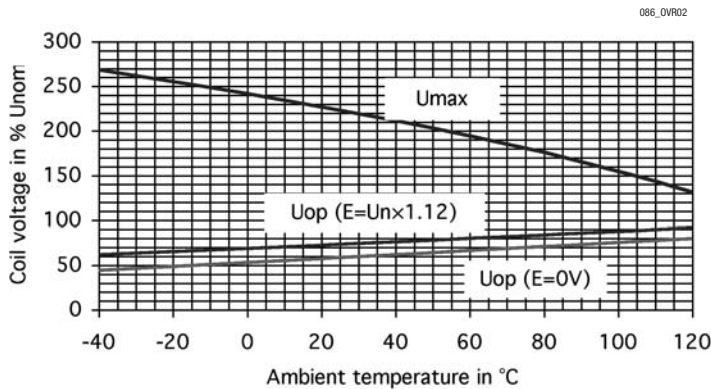

Does not take into account the temperature rise due to the contact current
E=pre-energization

Environmental conditions

Temperature range, storage	Refer to <i>Storage</i> in the "Glossary" at http://relays.tycoelectronics.com/appnotes/			
Test	Relevant standard	Testing as per	Dimension	Comments
Cold storage	IEC 68-2-1		1000 h	-40 °C
Dry heat	IEC 68-2-2	Ba	1000 h	125 °C
Climatic cycling with condensation	EN ISO 6988		20 cycles	Storage 8/16 h
Thermal change	IEC 68-2-14	Nb	35 cycles	- 40/+ 125 °C
Thermal shock	IEC 68-2-14	Na	1000 cycles	- 40/+ 125 °C Dwell time 1 h
Damp heat				
constant	IEC 68-2-3	Ca	56 days	40 °C / 93%
Corrosive gas	IEC 68-2-42	-	10 days	
	IEC 68-2-43		10 days	
Vibration resistance	IEC 68-2-6 (sine pulse form)		10 ... 500 Hz 6 g	No change in the switching state > 10 μs
Shock resistance	IEC 68-2-27 (half-sine form single pulses)		6 ms up to 30 g	No change in the switching state > 10 μs
Solderability	IEC 68-2-20	Ta, Method 1		Aging 3 (4 h/155 °C) Dewetting
Resistance to soldering heat	IEC 68-2-20	Tb, Method 1A		10 s ± 1 s with thermal screen
Sealing	IEC 68-2-17	Qc, Method 2		1 min / 70 °C

Double Micro Relay K

Ordering information

Part numbers (see table below for coil data)		Contact arrangement	Contact material	Enclosure	Terminals
Relay part number	Tyco order number				
V23086-C2001-A403	1413009-9	2 x Form C	AgSn02	Sealed	Printed circuit
V23086-C2002-A403	8-1419137-4	2 x Form C	AgSn02	Sealed	Printed circuit

Coil versions

Coil data for Double Micro Relay K	Rated coil voltage (V)	Coil resistance +/- 10% (Ω)	Must operate voltage (V)	Must release voltage (V)	Allowable overdrive ¹⁾ voltage (V)	
					at 23 °C	at 105 °C ¹⁾
V23086-**001-****	12	254	6.9	1.5	27	18
V23086-**002-****	10	181	5.7	1.25	22	15

¹⁾ Allowable overdrive is stated with no load applied and minimum coil resistance.

Standard delivery pack (orders in multiples of delivery pack)

Double Micro Relay K: 990 pieces