

Description

**MINI MIC RECEPTACLE AND TAB CONTACTS FOR
SINGLE WIRE SEALING.**

SCOPE

This Specification covers the requirements for application of Mini Mic rec. and tab contacts.

P/Ns involved are listed in the table of fig. 7.

GENERAL

These contacts are suitable for 0,35±2,5sqmm wire, with single wire seals.

Each wire is inserted into a discrete wire seal before to be crimped into the contact.

The insulation barrel is crimped so that the wire seal is gripped in order to avoid any movement of the seal.

The contacts are suitable for single wire only.

The indications on the figures are valid for both receptacle and tab contacts.

1.0 CRIMPING

The following information contains nomenclature, crimping conditions, crimp data for mini-applicators, insertion of wire seals on cables, mending or replacement of parts and checks.

1.1 NOMENCLATURE

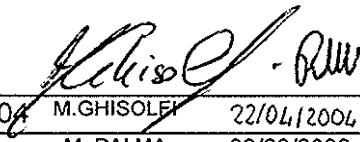

F3	REVISED & REDRAWN ET00-0024-04	M.GHISOLFI	22/04/2004	R.MARTINI	22/04/2004
F2	REVISED ET00-0416-99	M. PALMA	09/03/2000	R.MARTINI	10/03/2000
F1	REVISED ET00-0084-99	M. GHISOLFI	10/03/1999	R.MARTINI	16/03/1999
F	REVISED ET00-0488-97	DE RUVO	19/12/1997	A. BRUNI	20/02/1998
E	REVISED ET00-0154-97	P.S.	03/03/1997	C.BERTINI	24/03/1997
D	REVISED ET00-0294-95	S.SERRA	12/12/1995	G.CUMINO	12/12/1995
C	ADDED W.R. 1,5±2,5sqmm ET00-0138-93	C.PIA	25/10/93	A. BRUNI	05/11/93
B	UPDATED & RELEASED ECN I-3168	A. BRUNI	23/10/92	P.CASTELLO	23/10/92
rev letter	rev. record	DR	Date	CHK	Date
DR.		DATE	APVD		DATE
O. Canuto		19/12/1991	P. Castello		23/10/1992

This specification is a controlled document.

This AMP controlled document is subject to change. For latest revision call AMP Italia s.p.a., Collegno (TO), Italy.

* Trademark

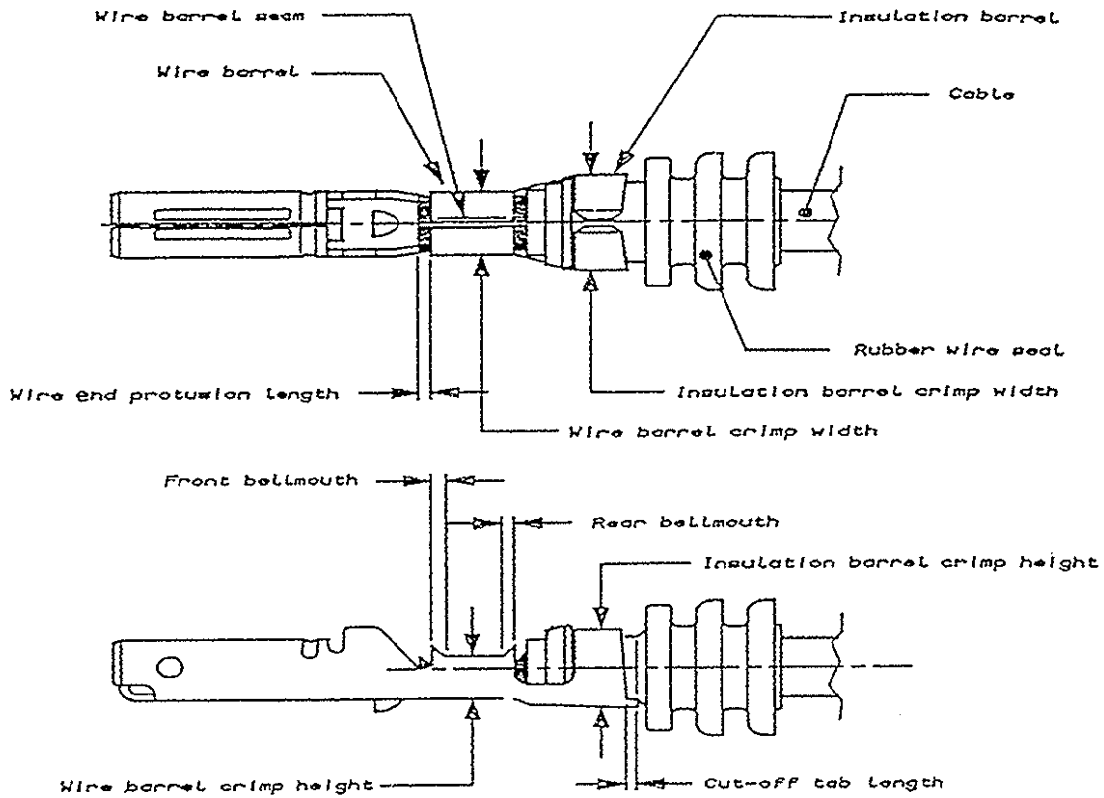

Fig. 1

2.0 CRIMPING CONDITIONS

With reference to nomenclature (par.1.1) see Fig. 1, Fig. 2 and Fig. 3.

- | | |
|--|-----------------|
| 1. Cut-off tab length | 0,3mm max. |
| 2. Front bellmouth | 0,10 x 45° max. |
| Rear bellmouth | 0,25 x 60° min. |
| 3. Bend up | 5° max. |
| Bend down | 5° max. |
| Bend right | 5° max. |
| Bend left | 5° max. |
| Rolling | 5° max. |
| 4. Cable end protrusion
(brush length) | 0,2 to 0,7mm |
| 5. Insulation stripping
length | 3,0 to 3,5mm |
| 6. Wire barrel seam must be neatly closed. | |

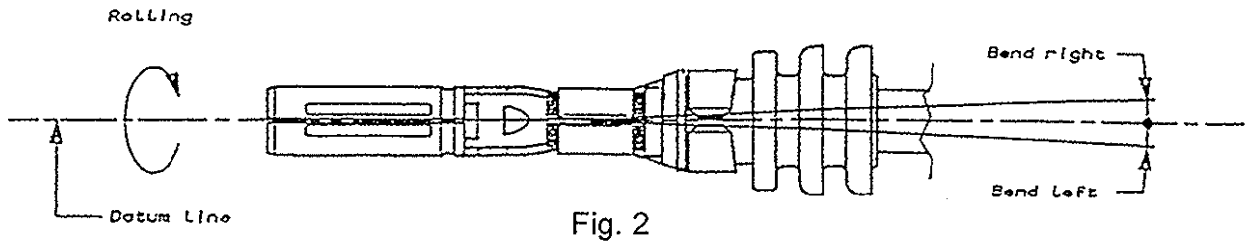

Fig. 2

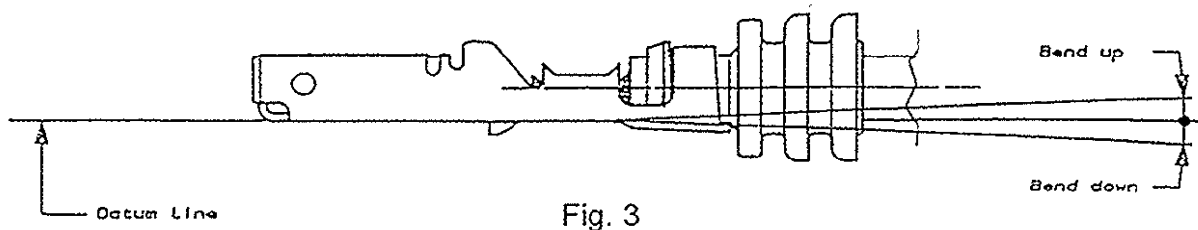

Fig. 3

3.0 CRIMP DATA

3.1 For applicator crimping see Fig. 7

4.0 INSERTION OF RUBBER WIRE SEAL ON THE CABLE

When the rubber seal is installed on cable, the end of the cable insulation shall be positioned from the edge of the rubber seal, as shown in Fig. 4. This length is usually regardless of cable size.

NOTE: Seals are supplied lubricated. This lubrication must not be removed.

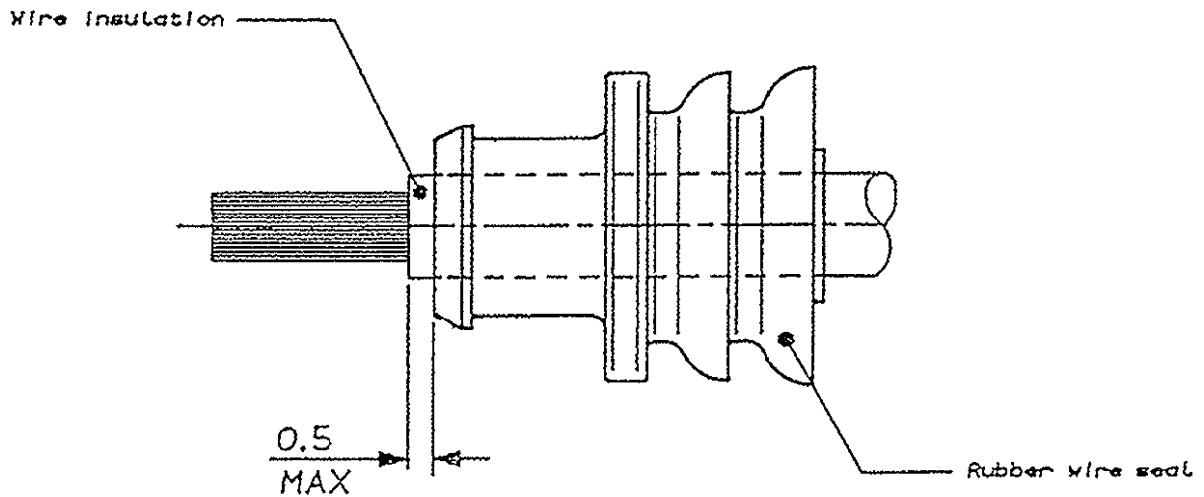
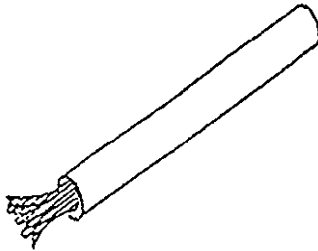

Fig. 4

5.0 CORRECTION OR REPLACEMENT OF PARTS

When defects and/or improper applications are found on parts to be installed, as shown in Fig. 5, rework to set up properly, or replace with new part.



The end of the cut wire shall appear neat without any bend or frayed conductor.

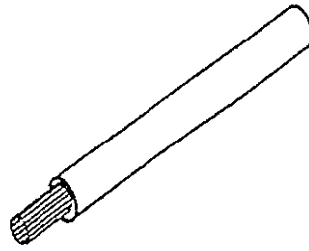

The conductor shall be free from nick, cut and scrape.

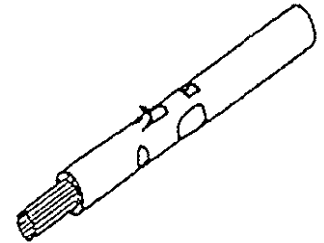

The wire insulation must have smooth surface in a round form without damage, groove or recessed surface.

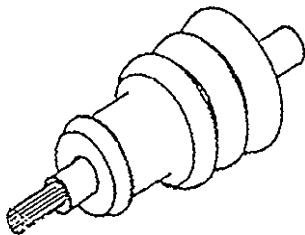

The end of the wire shall be straight without bend and untidiness after insertion of the wire seal. The bent wire seal be checked out.

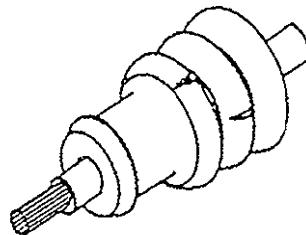

The flanges of the rubber seal shall be free from cut and damage. Any seal having such defects shall be discarded and replaced with new part.

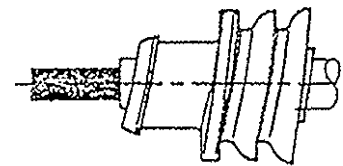

Insertion of rubber seal shall be done straightly and evenly. If flanges are in tilt condition, the plug must be corrected so that flanges are perpendicular to contact center line.

Fig. 5

AMP

5.1 After crimping, the part of the cable insulation that is inside the seal shall be in good condition and within the requirements shown in Fig. 5.
Check by visual inspection in the transition area (between wire and insulation barrel), as indicated in Fig. 6.

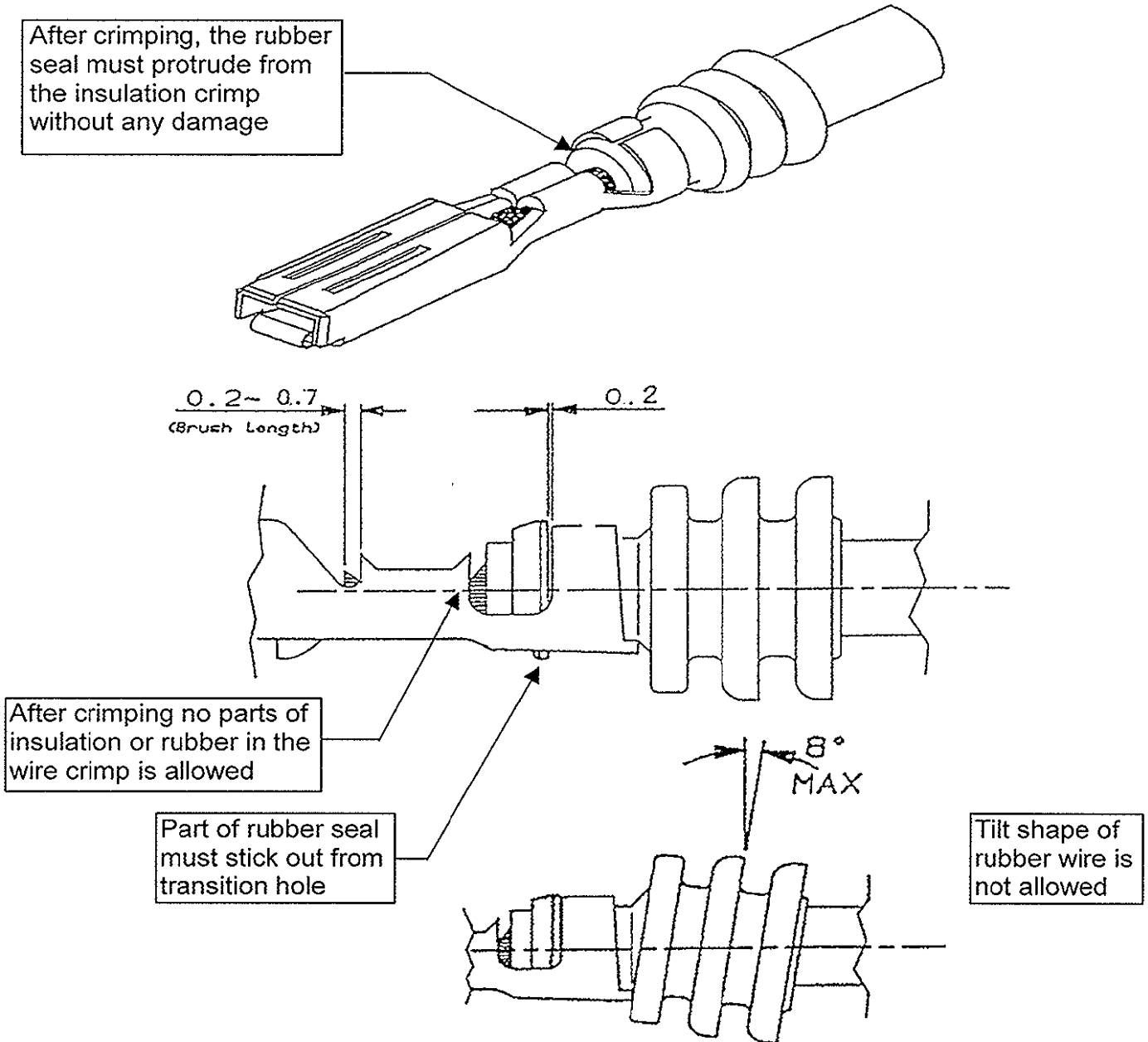

Fig. 6

5.2 Crimped contacts should appear as illustrated in par. 1.1 (Nomenclature).

PART NUMBER REC. CONTACTS	WIRE SIZE (sqmm)	INS.DIA FOR WIRE SEAL 281934-2	INS.DIA FOR WIRE SEAL 281934-3	INS.DIA FOR WIRE SEAL 281934-4	STRIP LENGTH	WIRE BARREL CRIMP			INSULATION BARREL CRIMP		
						CRIMPER HEIGHT ±0.05	CRIMPER WIDTH (REF.)	CRIMPER TYPE	CRIMPER WIDTH (REF.)	CRIMPER TYPE	CRIMPER HEIGHT (REF.)
282110-1	0.75	1.7 - 2.4	2.5 - 3.3	*****	3.0 - 3.5	1.14	2.28	F	3.68	O	3.75
	1.0					1.22					3.80
	1.5					1.40					4.00
282403-1	0.35	*****	*****	1.2 - 1.6	3.0 - 3.5	1.02	1.78	F	3.68	O	3.70
	0.5					1.09					3.75
282466-1	1.5	1.7 - 2.4	2.5 - 3.3	*****	3.5 - 4.0	1.72	2.28	F	4.19	O	4.00
	2.5					1.98					4.40

PART NUMBER TAB CONTACTS	WIRE SIZE (sqmm)	INS.DIA FOR WIRE SEAL 281934-2	INS.DIA FOR WIRE SEAL 281934-3	INS.DIA FOR WIRE SEAL 281934-4	STRIP LENGTH	WIRE BARREL CRIMP			INSULATION BARREL CRIMP		
						CRIMPER HEIGHT ±0.05	CRIMPER WIDTH (REF.)	CRIMPER TYPE	CRIMPER WIDTH (REF.)	CRIMPER TYPE	CRIMPER HEIGHT (REF.)
282109-1	0.75	1.7 - 2.4	2.5 - 3.3	*****	3.0 - 3.5	1.34	2.28	F	3.68	O	3.75
	1.0					1.45					3.80
	1.5					1.52					4.00
282404-1	0.35	*****	*****	1.2 - 1.6	3.0 - 3.5	0.99	2.03	F	3.68	O	3.70
	0.5					1.04					3.75
282465-1	1.5	1.7 - 2.4	2.5 - 3.3	*****	3.5 - 4.0	1.72	2.28	F	4.19	O	4.00
	2.5					1.98					4.40

PART NUMBER TAB CONTACTS	WIRE SIZE (sqmm)	INS.DIA. (IVECO TABLE 11-8140) (PHASE 2)	INS.DIA. (FIAT TABLE 91107/13 & 91107/15) (PHASE 3)	STRIP LENGTH	WIRE BARREL CRIMP			INSULATION BARREL CRIMP			
					CRIMPER HEIGHT ±0.05	CRIMPER WIDTH (REF.)	CRIMPER TYPE	CRIMPER WIDTH (REF.)	CRIMPER TYPE	CRIMPER HEIGHT (REF. PHASE 2)	CRIMPER HEIGHT (REF. PHASE 3)
284262-1	0.35	1.3 - 1.5	1.2 - 1.3	3.0 - 3.5	0.99	2.03	F	3.68	F	*****	2.00
	0.5	1.8 - 2.0	1.4 - 1.6		1.04					2.10	
	0.75	*****	1.7 - 1.9		1.34					2.15	
284263-1	1.0	2.2 - 2.4	1.9 - 2.1	3.0 - 3.5	1.45	2.28	F	3.70	F	3.55	3.25
	1.5	2.8 MAX.	2.2 - 2.4		1.52					3.75	3.30
	0.5+0.5	1.8-2.0+ 1.8-2.0	N/A		1.45					3.70	*****
	1.0+0.5	2.2-2.4 + 1.8-2.0	N/A		1.52					4.00	*****

(Dimensions are in mm)