

DUAL DISPLAY MULTIMETER

USER'S MANUAL

⚠ CAUTION

THIS IS AN IEC SAFETY CLASS 1 PRODUCT. THE GROUND WIRE IN THE LINE CORD MUST BE CONNECTED FOR SAFETY.

⚠ WARRANTY

Our company warrants to the original purchaser that each product it manufactures will be free from defects in material and workmanship under normal use and service for a period of one year from date of purchase. Our company's warranty does not apply to fuses, test leads or any product which, in our company's opinion, has been misused, altered, or damaged by accident or abnormal conditions of operation or handling.

To obtain warranty service, contact the nearest Service Center or send the product, with a description of the difficulty, and postage prepaid, to the nearest Service Center. We assume no risk for the damage in transit. We will, at its option, repair or replace the defective product free of charge or refund your purchase price. However, if we determine that the failure was caused by misuse, alterations, accident or abnormal condition of operation or handling, you will be billed for the repair and the repaired product will be returned to you transportation prepaid.

SHIPPING TO MANUFACTURER FOR REPAIR OR ADJUSTMENT

All shipment of our company's instruments should be made via United Parcel Service or "Best Way" prepaid. The instrument should be shipped in the original carton; or if it is not available, use any suitable container that is rigid and of adequate size. If a substitute container is used, the instrument should be wrapped in paper and surrounded with at least four inches of excelsior or similar shock-absorbing material.

CLAIM FOR DAMAGE IN SHIPMENT TO ORIGINAL PURCHASER

The instrument should be thoroughly inspected immediately upon original delivery to purchaser. All material in the container should be checked against the enclosed packing list. The manufacturer will not be responsible for shortages against the packing sheet unless notified immediately. If the instrument is damaged in any way, a claim should be filed with the carrier immediately. (To obtain a quotation to repair shipment damage, contact the nearest Service Center.) Final claim and negotiations with the carrier must be completed by the customer.

Section 1

Introduction

INTRODUCING THE DUAL DISPLAY MULTIMETER

In this manual, “WARNING” is reserved for conditions and actions that pose hazard(s) to the user; “CAUTION” is reserved for conditions and actions that may damage your meter.

NOTE

This manual contains information and warnings that must be followed to ensure safe operation and retain the meter in safe condition.

⚠ WARNING

READ THE “MULTIMETER SAFETY” SHEET BEFORE USING THE METER.

The Dual Display Multimeter is a 5-digit high resolution mode. The meter is designed for bench-top. The features provided by the meter are:

- A dual, Liquid Crystal, Display that allows two properties of an input signal to be displayed at the same time
- True rms AC.
- 30 MHz in frequency measurement
- 10 μ V sensitivity in volts DC
- Decibels with variable reference impedance measurement capability.
- A compare mode to determine if a measurement is within, above, or below a designated range.
- Slow and Fast selectable count resolution, with reading speeds of 3 and 6 reading per second, respectively.
- Built-in self-tests with closed-case calibration (no internal calibration adjustment).
- Isolation of Universal Serial Bus(USB) Port
- Remote Control, display, record, Data Analysis, print with computer.

WHERE TO GO FROM HERE

This manual has been organized to assist you in getting started quickly. It is not necessary for you to read the entire manual before using the meter effectively. However, we recommend that you do so in order to use your meter to its full advantage.

Begin by scanning the Table of Contents to familiarize yourself with the organization of the manual. Then, read Section 2, “GETTING STARTED”. Refer to the appropriate section of the manual as needed. The contents of each section are summarized below.

SECTION 1. INTRODUCTION

Introduces the Dual Display Multimeter, describing its features and users manual.

SECTION 2. GETTING STARTED

Explains how to prepare the meter for operation and get started quickly taking basic measurements from the front panel.

SECTION 3. OPERATING THE METER FROM THE FRONT PANEL

Provides a complete description of each operation that can be performed using the pushbuttons on the front panel. Section 3 is organized so that related operations and functions are grouped together.

SECTION 4. MAINTENANCE

Describes how to perform basic maintenance and how to replacing fuses as order

SECTION 5. CALIBRATION

Introduces the required equipment, ambient environment station for calibration and the process of calibration.

SECTION 6. SPECIFICATIONS

MULTIMETER SAFETY

The Dual Display Multimeter has been designed and tested according to IEC Publication 1010 Safety Requirements for Electronic Measuring Apparatus. This manual contains information and warnings

which must be followed to ensure safe operation and retain the meter in safe condition. Some common international electrical symbols used in this manual are shown below.

○	OFF(power) SWITCH POSITION	⚡	DANGEROUS VOLTAGE
	ON(power) SWITCH POSITION	⬇	EARTH GROUND
~	AC-ALTERNATING CURRENT	⚠	WARNING INFORMATION
---	DC-DIRECT CURRENT		

Before using the meter, read the following safety information carefully.

- Avoid working alone.
- Follow all safety procedures for equipment being tested.
- Inspect the test leads for damaged insulation or exposed metal. Check test lead continuity. Damaged leads should be replaced.
- Be sure the meter is in good operating condition.
- Select the proper function for your measurement.
- To avoid electrical shock, display “ ⚡ ” when working above 30V dc or 30V ac RMS.
- Disconnect the live test lead (VΩ) before disconnecting the common test lead (COM).
- Disconnect the power and discharge high-voltage capacitors before testing in Ω, 🔊 and .
- When making a current measurement, turn the circuit power off before connecting the meter in the circuit.
- Check meter fuses before measuring transformer secondary or motor winding current; (See Section 4, “MAINTENANCE”) An open fuse may allow high voltage build-up, which is potentially hazardous.

Section 2

Getting Started

INTRODUCTION

Section 2 explains how to prepare the meter for operation, discusses general operating features, and walks you through the basics of taking some common measurements,

GETTING STARTED

Unpacking and Inspecting the Meter

Carefully remove the meter from its shipping container and inspect it for possible damage or missing items. If the meter is damaged or something is missing, contact the place of purchase immediately. Save the container and packing material in case you have to return the meter.

Front Panel and Rear Panel

The front panel (shown in Figure 2-1) has three main elements: the input terminals on the right, the display and the pushbuttons.

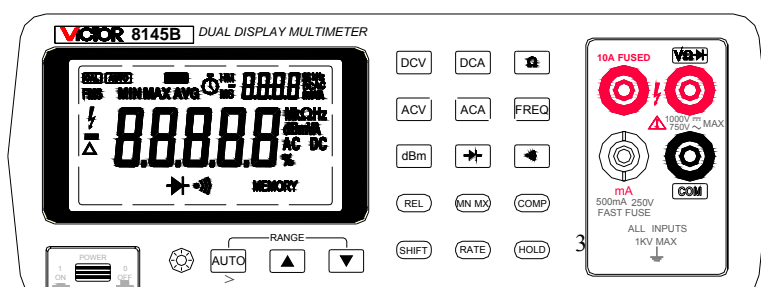

The pushbuttons are used to select major functions, ranging operations, and function modifiers. These elements are described in detail in Section 3.

Figure 2-1. Front Panel

The rear panel (shown in Figure 2-2) contains the power-line cord connector, communication interface, the Serial Number Label.

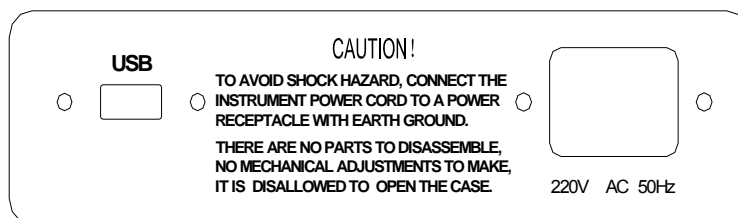

Figure 2-2. Rear Panel

ADJUSTING THE HANDLE

For bench-top use, the handle can be positioned to provide different viewing angles. To adjust its position, pull the ends out to a hard stop and rotate it to a position. To remove the handle, adjust it to the vertical stop position and pull the ends all the way out.

POWER

⚠ CAUTION

TO AVOID SHOCK HAZARD, CONNECT THE INSTRUMENT POWER CORD TO A POWER RECEPTACLE WITH EARTH GROUND.

NOTE

Apply the rated voltage and frequency to the meter as marked on the rear panel of the meter.

TURING THE METER ON

To turn the meter on, press the **POWER** button located on the lower-left of the front panel. If you turn the meter off, you must wait five seconds before turning the meter back on. If you do not, the meter will not power-up.

When the meter is turned on, the full screen displays light while the instrument performs an internal self-test of its digital circuitry. These tests check RAM, ROM, A/D, and the display. The meter has passed all tests and is ready for normal operation if an error code is not displayed.

After the meter completes the power-up sequence, it assumes the power-up measurement configuration stored in non-volatile memory. The power-up configuration set at the factory is shown in Table 3-6. (To change the power-up configuration, refer to “CHANGING THE POWER-UP CONFIGURATION” in Section 3.)

USING THE PUSHBUTTONS

The pushbuttons on the front panel select meter functions and operations. A summary of basic pushbutton operations is shown in Figure2-3.

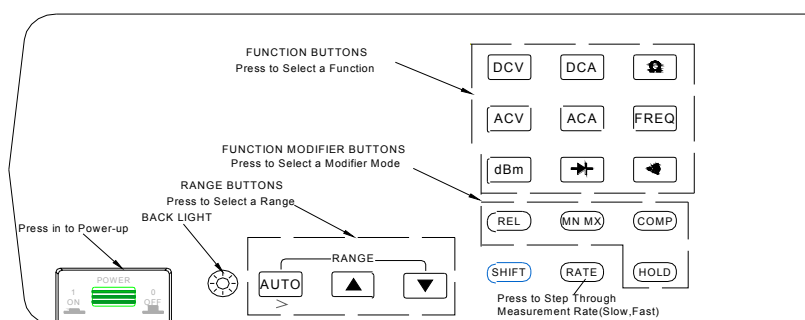

Figure 2-3. Summary of Basic Pushbutton Operations

Pushbuttons can be used in two ways. You can:

- Press a single button to select a function or operation.

EXAMPLE: Press **ACV** to select volts ac function.

- Press a combination of buttons, one after the other.

EXAMPLE: Press **ACV** to select volts ac function, and then press **REL** to select the decibels modifier.

For more details on the uses of each button, refer to Section 3, "OPERATION THE METER FROM THE FRONT PANEL."

SELECTING A MEASUREMENT RANGE

Measurement ranges can be selected automatically by the meter in "autorange" or manually by the user. In the autorange mode, the meter selects the appropriate range for the measurement reading.

To manually select a range, press **AUTO** to toggle in (and out) of the manual ranging mode, or press **▼** in the manual range mode, press **▲** or **▶** to up range or down range to the desired range. For more details on ranging, refer to "RANGING" in Section 3.

TAKING SOME BASIC MEASUREMENTS

⚠ WARNING

READ "MULTIMETER SAFETY" BEFORE OPERATING THIS METER.

The following procedures describe the basics of taking common measurements from the front panel. These procedures are provided for the user who needs to get started quickly, but dose not want to read the rest of the manual at this time. However, in order to take full advantage of your meter, you should read the remainder of this manual carefully and completely.

⚠ WARNING

TO AVOID ELECTRICAL SHOCK OR DAMAGE TO THE METER, DO NOT APPLY MORE THAN 1000V (PEAK) BETWEEN ANY TERMINAL AND EARTH GROUND. THE METER IS PROTECTED AGAINST OVERLOADS UP TO THE LIMITS SHOWN IN TABLE 3-1. EXCEEDING THESE LIMITS POSES A HAZARD TO THE METER AND OPERATOR.

Measuring Voltage, Resistance, or Frequency

To measure voltage, resistance, or frequency, press the desired function button and connect the test leads as shown in Figure 2-4. The meter will select the appropriate range in the autorange mode.

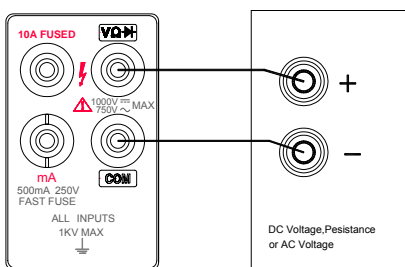

Figure 2-4. Measuring DC Voltage, Resistance, AC Voltage

Measuring Current

To measure current, insert the red test lead in the mA input terminal for currents up to 330mA or in the 10A input terminal for higher current, and insert the black test lead in the COM terminal.

Connect the test leads as shown in Figure 2-5.

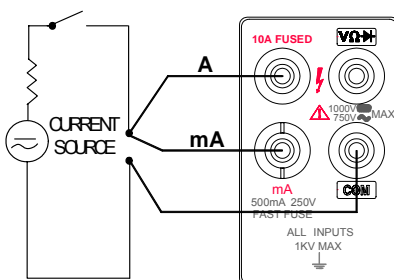

Figure2-5. Measuring Current

NOTE

After measuring high current using the 10A input, thermal voltages are generated that may create errors when making low-level dc measurements of volts, current, or ohms. To make the most accurate measurements, allow up to ten minutes for the thermals to settle out.

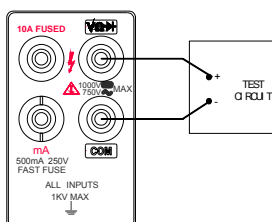

Figure 2-6. Continuity Testing

Diode/Continuity Testing

The continuity test determines whether a circuit is intact (i.e., has a resistance less than about 150Ω). To perform a continuity test, press **▶**, and connect the test leads as shown in Figure 2-6. The beeper emits a

continuous beep when the input drops below 150Ω (Beep condition can be changed, refer to “Changing the Power-UP Configuration” later in Section 3), and the readings for the test circuit are displayed.

The diode test measures the forward voltage of a semiconductor junction at approximately 0.8mA. Readings are displayed in the 3V range at the fast measurement rates. “OL” is displayed for voltages above 2.0V. Under normal measurement condition, the positive pole of diode is connected with the black test lead.

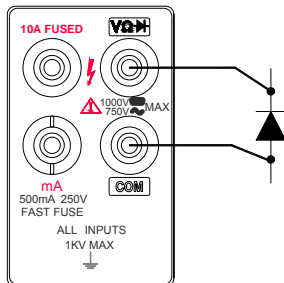

Figure 2-7. Diode Testing

To perform a diode or transistor junction test, press to select the diode function. Then connect the test leads across the diode as shown in Figure 2-7.

Notice how the test leads are placed. Reversing the polarity will reverse-bias the diode.

dBm (Decibels) measure

The decibels modifier takes an ac voltage measurement, converts it to dBm (measure of decibels relative to one milliwatt), and displays the result on the primary display. Connect the test leads as shown in Figure 2-4.

Press to toggle in and out of the decibels mode. When the decibels mode is selected, “dBm” is shown on the primary display, AC voltage value is shown on the secondary display.

Decibels can be selected only when ac voltage function is selected. Decibels are always displayed in a single, fixed range with 0.01 dB resolution. Press the toggle in and out autorange, you can also press the and manually.

A voltage measurement is converted to dBm using the following formula:

$$\text{dBm} = 10 \cdot \lg (1000 \cdot \text{value}^2 / \text{reference impedance})$$

where “value” is the measurement value, and displayed on the secondary display. The reference impedance can be changed. (Refer to “Changing the Power-UP Configuration” later in Section 3).

Communication Interface

The real time measured value can be transmitted to the computer by the devote USB cable and the VICTORVIEW_8145B software (refer to “using the communication function” in section 3).

SECTION 3

Operating the Meter from the Front Panel

INTRODUCTION

Section 3 explains how to operate the meter from the front panel.

FRONT PANEL OPERATIONS

The following operations can be performed from the front panel:

- Select a measurement function (, , , , , , and)
- Select function modifiers that cause the meter to display relative readings (), minimum, maximum or average values ()
- Enter the Touch Hold mode () to hold a reading on the display
- Set Measurement Rate (), change the rate as “F”(Fast) or “S”(Slow)
- Take a measurement and compare () it to a setting value
- Select the manual or autorange mode (), up range or manually

to desired range

- Turn on or turn off the back light (when arrive the setting time the back light can automatically off)
- Power-on or off the power supply (**POWER**)

These operations are described in remainder of Section 3.

DISPLAY

The meter has a 5-digit, Liquid Crystal Display (Primary Display) and a 4-digit, Liquid Crystal Display (Secondary Display). The display shows measurement readings, measurement units and messages. As shown in Figure 3-1.

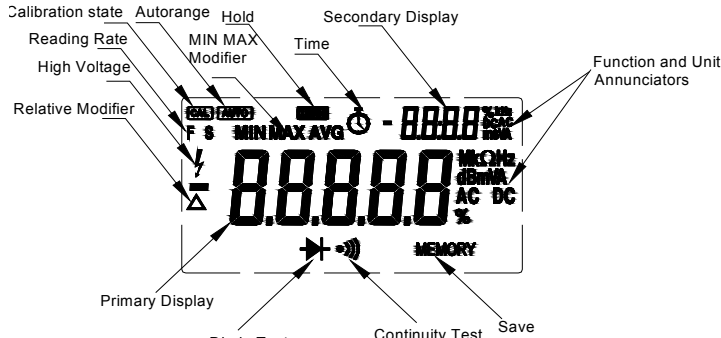
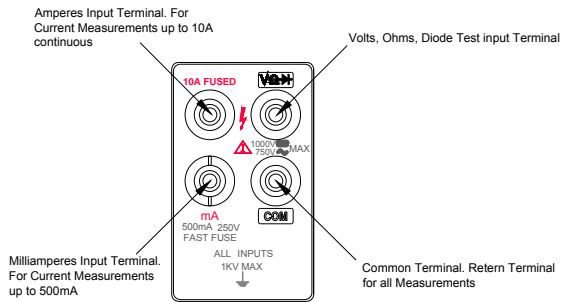

Figure 3-1. Display Annunciators



INPUT TERMINALS

The input terminals, as shown in Figure 3-2, are located on the right of the front panel

The meter is protected against overloads up to the limits shown in Table 3-1. Exceeding these limits poses a hazard to both the meter and operator.

Figure 3-2. Input Terminals

Table 3-1. Input Limits

FUNCTION	INPUT TERMINALS	MAXIMUM INPUT
V $\overline{\text{---}}$	V Ω \rightarrow and COM	1000V dc on all ranges
V \sim , FREQ and dBm	V Ω \rightarrow and COM	750V ac rms, 1000V peak on all ranges
mA $\overline{\text{---}}$ and mA \sim	mA and COM	500mA dc or ac rms
A \sim and A \sim	10A and COM	10A dc or ac rms
Ω	V Ω \rightarrow and COM	250V dc or ac rms on all ranges
\rightarrow	V Ω \rightarrow and COM	250V dc or ac rms on all ranges
All Functions	Any terminal to earth	1000V dc or ac peak

SELECTING A MEASUREMENT FUNCTION

Press a function button, as shown in Figure 3-3, to select a measurement function. When you select a function, annunciators turn on to indicate the function selected. Rang and full scale values are summarized in Table 3-2 for voltage, current, ohms and frequency

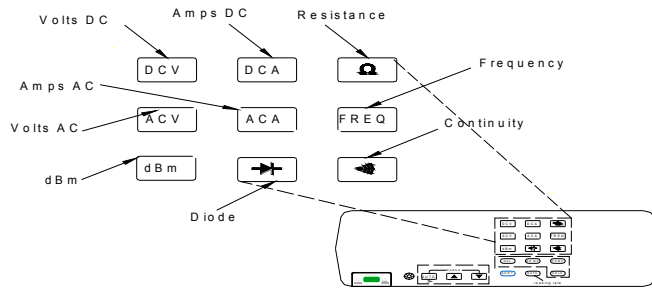

Figure 3-3. Function Select Buttons

Table 3-2. Voltage, Current, Ohms and Frequency Rang and Full Scale Value

FUNCTION	RANG	FULL SCALE	INFORMATION
V ~ and V ---	300mV	330.00mV	*760V ac rms
	3V	3.3000V	
	30V	33.000 V	
	300 V	330.00 V	
	1000V*	1100.0 V*	
mA ~ and mA ---	0.3mA**	0.33000 mA**	**AC current have not 0.3mA and 3mA range
	3mA**	3.3000 mA**	
	30mA	33.000 mA	
	300 mA	330.00 mA	
A ~ and A ---	10A	11.000A	
Resistance	300Ω	330.00Ω	
	3KΩ	3.3000 KΩ	
	30 KΩ	33.000 KΩ	
	300 KΩ	330.00 KΩ	
	3MΩ	3.3000 MΩ	
	30 MΩ	33.000 MΩ	
	100 MΩ	110 MΩ	
Frequency	300Hz	330.00 Hz	30MHz range have not full scale
	3KHz	3.3000 KHz	
	30KHz	33.000 KHz	
	300KHz	330.00 KHz	
	3MHz	3.3000 MHz	
	30MHz	/	

ANGING (AUTO, ▲, ▼)

Ranging operations are performed using the AUTO, ▲ and ▼ buttons (see Figure 3-4).

Autoranging

When you are in the autorange mode, the “AUTO” annunciator is lit.

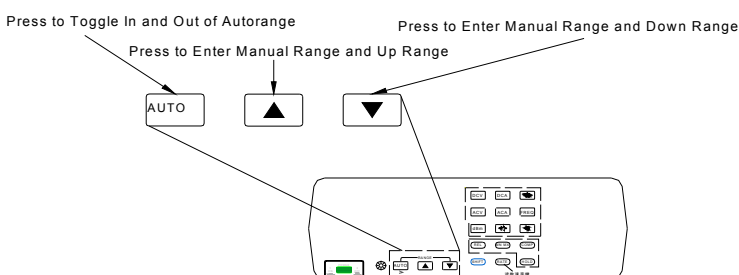

In autorange, the meter automatically selects the next higher range when a reading is greater than full scale. If no higher range is available, “OL” (overload) is displayed. The meter automatically selects a lower range when a reading is less than approximately 10% of the selected range.

Figure 3-4. Range Selection Buttons

Manual Ranging

Press **AUTO** to toggle in and out of manual ranging. The range you are in when you enter the manual range mode becomes the selected range.

In manual range, the meter remains in the selected range regardless of input. Press **AUTO** to toggle back to autoranging.

Press **▲** to up range. If the **▲** is pressed when the meter is still in autorange, manual ranging is selected, the "AUTO" annunciator turns off, and the next higher range is selected (if there is one).

Press **▼** to down range. If the **▼** is pressed when the meter is still in autorange, manual ranging is selected, the "AUTO" annunciator turns off, and the next lower range is selected (if there is one).

When one function of Volts DC, Amps DC, Volts AC, Amps AC, Resistance or FREQ is selected, the selected range is displayed on the secondary display.

MEASURING FREQUENCY (**FREQ**)

Press the **FREQ** button to select the frequency function, the frequency is displayed on the primary display and the selected range is displayed on the secondary display. Select the range manually or automatically

Frequency Measurement Rates

The rate at which frequency measurements are taken is selected by the meter automatically, when the frequency function has been selected, press **RATE** has no effect on the frequency update rate.

Frequency Sensitivity Selection

Before a frequency measurement is started, the amplitude of the input signal is sampled and the optimum ac voltage range is selected automatically. For more information refer to the Section 6 for ac voltage sensitivity.

The input signal sensitivity is based on sine waveforms. If the input signal is below the required level, the frequency will be displayed as zero. If the measurements are unstable, the input signal may be near the threshold level.

SELECT A FUNCTION MODIFIER (**REL** , **HOLD** , **MNMX** , **COMP**)

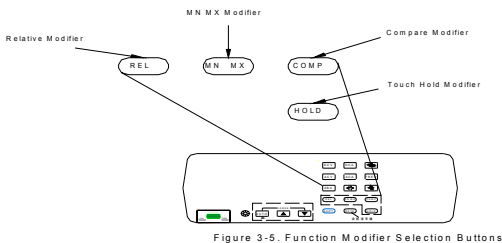

Selecting a function modifier causes the meter to perform an action on an input (e.g., convert to relative reading mode or compare to another value) before a reading is displayed. To use a function modifier, press a function button to select a primary function, and then press a function modifier button. See Figure 3-5

REL (Relative Readings) Modifier

Press **REL** to select the relative modifier. When the relative modifier is selected: the last valid reading is stored as the relative base and displayed on the secondary display. The reading on the primary display is always the difference between the relative base and an input measurement, and the "Δ" annunciator turn on.

REL=present reading - relative base

For example, if the relative base is 15.000V, and the present reading is 14.100V, the display will show -0.900V.

⚠ WARNING

REMEMBER, A RELATIVE READING MAY NOT INDICATE THE PRESENCE OF DANGEROUS VOLTAGES AT THE INPUT CONNECTORS OR TEST LEADS. USE CAUTION TO AVOID ELECTRICAL SHOCK OR DAMAGE TO THE METER.

Press **REL** again, the relative base is displayed on the secondary display. The reading on the primary display is REL%, and the "%" annunciator turn on simultaneous.

$$\text{REL}\% = \frac{\text{present reading} - \text{relative base}}{\text{relative base}} \times 100\%$$

For example, if the relative base is 15.000V, and the present reading is 14.100V, the display will show -6%. Press **REL** again to exit the relative modifier.

NOTE

The relative modifier cannot be selected if the display shows "OL" or is blank. (The display would be blank, for example, because of range changes.)

Selecting the relative modifier (REL) turns off autoranging and locks in the present range. Make sure you are in the correct range before selecting the relative modifier. If you press other buttons after the relative modifier has been selected, you will automatically exit REL.

HOLD (Touch Hold) Modifier

The Touch Hold modifier allows you to hold the measurement reading on the display.

Press **HOLD** to select the Touch Hold modifier. When Touch Hold is selected, "HOLD" annunciator is lit on, and the beeper emits a single beep. Press **HOLD** again to exit Touch Hold modifier, and the beeper emits a single beep.

MN MX AVG (Minimum Maximum Average) Modifier

The MN MX modifier causes the meter to store the minimum and maximum inputs measured since the MN MX AVG modifier was selected. Press **MN MX** to select the MN MX AVG modifier. When the MN MX AVG modifier is first selected, the minimum, maximum and average values are set to the displayed reading and the "MAX" annunciator lights, once the maximum value showed on the primary display, the beeper emits a single beep. Press **MN MX** again to display the minimum reading and the "MIN" annunciator lights, once the minimum value showed on the primary display, the beeper emits a single beep. Press **MN MX** again to display the average reading on the primary display ("AVG" annunciator lights). Each subsequent press the **MN MX** button toggles among the minimum, maximum and average measurements taken. The measurement reading displayed on the secondary display. To exit the MN MX AVG modifier, press and hold down the **MN MX** button for two seconds or press other function buttons.

Selecting the MN MX AVG modifier turns off autoranging and locks in the present range. Make sure you are in the correct range before selecting the MN MX AVG modifier.

COMP (Compare) Modifier

The compare function (COMP) provides an easy way to determine if a reading falls within a designated range of values. In the compare mode, the meter displays a reading in the secondary display and indicates in the primary display if that value is lower (CO-LO) than, higher (CO-HI) than, or within a range (PASS) you selected, if the reading lower or higher, the beeper emits a continuous tone. Compare Modifier can be used under dc voltage, ac voltage, dc current, ac current and ohm function, in compare mode, the meter is in manually range mode..



Following the step to enter Compare Modifier

- Select a function and a range
- Press **COMP** to toggle in Compare Modifier
- Before selecting the compare function, set the high and low compare point first, when compare modifier selected, "MAX" annunciator lights, and the leftmost digit on the primary display is flashing, then can set the high point, press **AUTO** to select the digit to be set, each press **AUTO** causes the digit to the right to be selected and flashing, press **▲** or **▼** to **▲** or down the flashing digit. Press the **COMP** again, "MIN" annunciator lights, and the leftmost digit on the primary display is flashing, then can set the low point, press **AUTO** to select the digit to be set, each press **AUTO** causes the digit to the right to be selected and flashing, press **▲** or **▼** to up or down the flashing digit. Each subsequent press the **COMP** button toggles between high set, low set and compare measurements taken. To exit the Compare Modifier, press and hold down the **COMP** button for two seconds or press other function buttons.

Selecting the Compare Modifier turns off autoranging and locks in the present range. Make sure you are in the correct range before selecting the Compare Modifier.

The function modifier is relative to the measurement function refer to the Table 3-5

Table 3-5. function modifier and measurement function

FUN. Modifier Function	REL	HOLD	MNMX	COMP
DCV	√	√	√	√
ACV	√	√	√	√
DCA	√	√	√	√
ACA	√	√	√	√
Ω	√	√	√	√
FREQ		√		
		√		
		√		
dBm		√		

SELECTING A MEASUREMENT RATE (RATE)

The meter takes measurements at one of two, user-selectable rates: slow and fast. The rate selected is indicated by “S”, “F” on the display.

Press the **[RATE]** to change the measurement rates at “S” or “F”. The selected rate applies to DCV,

DCA, Ω, ACV, ACA, dBm.

Note:

- In Diode and Continuity Testing, the default rate is “F”
- In 30M Ω and 300M Ω rang, the default rate is “S”

Connect with the USB

Plug the one end of the devote USB cable to the communication connector on the real panel, plug the other end of the cable to the USB port of the computer, running the devote DMMVIEW_8145B software, set the corresponding connector port to achieve online. When success, the COMM annunciator is lit on, the instrument transmits measured value and state to computer, thus, the computer can remote Control, display, record, Data Analysis, print all the measurement process. use the software stop the communication, the instrument stop transmit measured value and the COMM annunciator disappear .

POWER-UP CONFIGURATION

Factory Setting of Power-Up Configuration

When the meter is turned on and completes the power-up sequence, it assumes its power-up configuration. The power-up configuration set at the factory is shown in Table3-6.







Table 3-6. Power-Up Configuration Set at Factory

PARAMETER	CONFIGURATIONS	REMARK
Function Setting	DC volt (DCV)	
Range Mode	Autorange (AUTO)	
Reading Rate	Slow (S)	
Reference Impedance (for dBm)	600Ω	Changeable
Compare set value	0	

MIN/MAX/AVG	0	
Relative Base value	0	
Frequency of Power	50Hz	Changeable
Back Light Time	0000 S	Changeable
Continuity beep	when the input drops below 150Ω	Changeable
Compare beep	if the reading lower or higher set value	Changeable

Changing the Power-Up Configuration

You can change the power-up configuration to one that more closely meet your needs and preferences. To change the Power-Up Configuration, power-up the meter and press **SHIFT** simultaneity

1. Change Back Light Time: Press **AUTO**, when “bLOFF” is annunciator showed on the primary display. The value of setting is showed on the secondary display, then press  or  to step up or down the setting value with 30S. The limit of the setting value is 3600S(1 hour), when the setting value is “0000” indicates that back light only be turned off manually. Press the **HOLD** save the set value, the “memory” annunciator is lit on.
2. Change Frequency of Power: Press **AUTO**, when “FrSET” annunciator is showed on the primary display, the Frequency is showed on the secondary display, then press  or  to select the frequency at 50Hz or 60Hz. (Once change the Frequency of Power, the meter should be calibrated newly). Press the **HOLD** save the set value, the “memory” annunciator is lit on.
3. Change the Reference Impedance: Press **AUTO**, when “CONS” annunciator is showed on the primary display, the Reference Impedance is showed on the secondary display. Then press  or  select the needed value (supplied value are 50, 75, 93, 100, 150, 300, 500, 600, 800, 1200, 2400 (unit: Ω)). Press the **HOLD** save the set value, the “memory” annunciator is lit on.
4. Change the continuity beep mode: Press **AUTO**, when “CH-BB” annunciator is showed on the primary display, the “YES”(connect beep) or ”NO”(disconnect beep) is showed on the secondary display. Press the **HOLD** save the set value, the “memory” annunciator is lit on.
5. Change the compare beep mode: Press **AUTO**, when “CO-BB” annunciator is showed on the primary display, the “YES”(inside the limiter) or ”NO”(exceed the limiter) is showed on the secondary display. Press the **HOLD** save the set value, the “memory” annunciator is lit on.
6. Factory set: Press **AUTO**, when “FACTY” annunciator is showed on the primary display, select the default factory set. To resume the factory set, Press the **HOLD** save the default value. To exit factory set mode, power off the instrument.

SECTION 4

Maintenance

NOTE

When servicing the meter, use only the replacement parts specified

INTRODUCTION

Section 4 provides the information necessary for the user to perform basic maintenance. Users should not attempt to perform maintenance not described in this section. Qualified service personnel should refer to this Manual for complete maintenance, service.

CAUTION

TO AVOID ELECTRICAL SHOCK OR DAMAGING THE METER, NEVER GET WATER INSIDE

THE CASE. TO AVOID DAMAGING THE METER HOUSING, NEVER APPLY SOLVENTS TO THE METER. IF THE METER REQUIRES CLEANING, WIPE IT DOWN WITH A CLOTH THAT IS LIGHTLY DAMPENED WITH WATER OR A MILD DETERGENT. DO NOT USE AROMATIC HYDROCARBONS, CHLORINATED SOLVENTS, OR METHANOL-BASED FLUIDS WHEN WIPING DOWN THE METER.

THE LINE FUSE

CAUTION

OPENING THE CASE MAY EXPOSE HAZARDOUS VOLTAGES. ALWAYS DISCONNECT THE POWER CORD AND MEASURING INPUTS BEFORE OPENING THE CASE.

1. Remove the screw **on each side of the real bezel.**
2. Remove the case from the meter. The fuse is visible at the front of the main printed circuit assembly near the power. The meter uses a 0.2A, 250V (Slow blow) line fuse.
3. Carefully remove the fuse and replace it with one rated as listed above
4. Reverse the disassembly procedure to reassemble the meter.

CURRENT INPUT FUSES

300mA (include 300mA) and 10A inputs are protected by user-replaceable fuses.

- The 300mA input is protected by a fuse rated at 500mA, 250V (Fast blow).
- The 10A input is protected by a fuse rated at 11A, 250V (Fast blow).

Testing Current Input Fuses

Perform the following procedure to test these fuses:

1. Short the $V\Omega$ \rightarrow input terminal and the mA terminal with a test lead.
2. Press \square to select the ohms function. Insert the test lead probe into the mA input terminal. If the fuse is good, the meter will read between 1Ω to 19Ω . If the fuse is blown, the meter will read $>10M\Omega$ to OL.
3. Remove the test lead probe from the mA input terminal and insert it into the 10A input terminal. If the fuse is good, the meter will read between 0.00 and 0.05 Ω . If the fuse is blown, the meter will read $>10M\Omega$ to OL.

Replacing the mA Input Fuse

CAUTION

FOR PROTECTION AGAINST FIRE, REPLACE A BLOWN FUSE ONLY WITH ONE OF IDENTICAL

The mA input fuse is mounted in the front panel input jack (see Figure 3-2). To replace this fuse, first unplug the line cord. Then press in on the input jack and turn it 90 degrees counter-clock wise, slide out the fuse holder and fuse.

Replace a blown fuse with one of identical rating and reinsert the fuse and holder into the input terminal socket. Secure the fuse holder by pressing in and turning the holder 90 degrees clockwise.

Replacing the 10A Input Fuse

CAUTION

OPENING THE CASE MAY EXPOSE HAZARDOUS VOLTAGES. ALWAYS DISCONNECT THE POWER CORD AND MEASURING INPUTS BEFORE OPENING THE CASE.

The 10A input fuse is located inside the meter. To replace the fuse:

1. Remove the screw on the bottom of the case.
2. Remove the case from the meter. The fuse is visible on the main printed circuit, which is connected with the 10A input terminal.
3. Carefully remove the fuse and replace it with one rated as listed above.
4. Reverse the disassembly procedure to reassemble the meter.

PERFORMANCE TESTS

The meter should be calibrated and in operating condition when you receive it.

The following performance tests are provided to ensure that the meter is in proper operating condition. If the instrument fails any of the performance tests, then calibration adjustment and/or repair is needed. To perform these tests, you will need a 5520A Multifunction Calibrator or equivalents. Each of the measurements listed in the following steps assume the instrument is being tested after a one-hour warmup, in an environment with an ambient temperature of 18 to 28°C, and a relative humidity of less than 70%.

NOTE

All measurements listed in the performance test tables are made in the slow reading rate unless otherwise noted.

1. Connect a test lead from the Output NORMAL HI and LO connectors of the 5520A to the $\boxed{V\Omega}$ and COM connectors on the meter (see Figure 4-1).

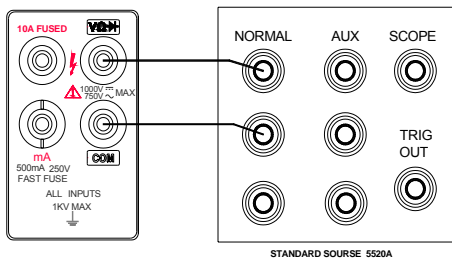

Figure 4-1

Select the Volts dc, Volts ac, Resistance or Frequency function and range on the meter and the input level from the 5520A. The display should meet the request listed in Section 6.

2. Connect a test lead from the output AUX HI and LO connectors of the 5520A to the mA and COM connectors on the meter (see Figure 4-2). Select the Current ac or Current dc function and 300mA range on the meter and the input level from the 5520A. The display should meet the request listed in Section 6.

the meter and the input level from the 5520A. The display should meet the request listed in Section 6.

3. Connect a test lead from the output 20A HI and LO connectors of the 5520A to the 10A and COM connectors on the meter (see Figure 4-3). Select the Current dc or Current ac function and 10A range on the meter and the input level from the 5520A. The display read should meet the request listed in Section 6.

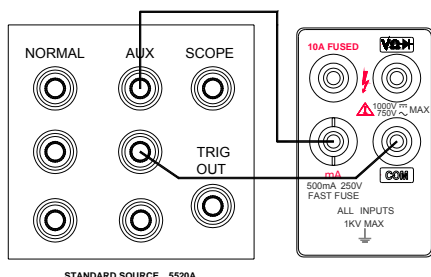

Figure 4-2.

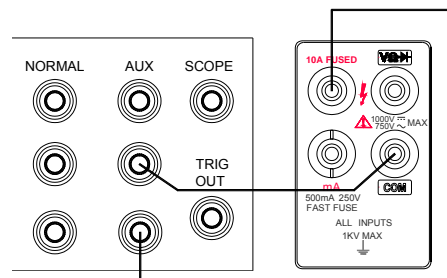

Figure 4-3.

SERVICE

If you suspect that the meter has failed, review this manual to make sure you are operating it correctly. If the meter still fails to operate properly, pack it securely (in its original container if available) and forward it, postage paid, to the nearest Service Center. Assumes no responsibility for damage in transit.

SECTION 5

Calibration

INTRODUCTION

To ensure the accuracy and the stability of the meter, the meter should be calibrated on a regular cycle of one year.

REQUIRED EQUIPMENT (refer to the table5-1)

Table5-1. Recommended Test Equipment

Measurement	Multifunction Range	Accuracy± (%Output)	Recommended Equipment
DCV	300mV,3V,30V,300V, 1000V	0.0002	FLUKE 5520A
ACV	300mV,3V,30V,300V, 1000V	20~50Hz 0.025 50 Hz~10KHz 0.015 10~20KHz 0.022 20~50KHz 0.03	
OHMS	300Ω,3KΩ,30KΩ, 300KΩ	0.004	
	3MΩ,30 MΩ,100 MΩ	0.05	
DCA	0.3mA, 3mA, 30mA, 300mA	0.025	
	10A	0.1	
ACA	3mA, 30mA, 300mA	20~50Hz 0.09	
		50 Hz~1KHz 0.04	
		1~5KHz 0.1	
		5~10KHz 0.16	
	10A	10~30KHz 0.32	
		50 Hz~5KHz 0.1	
FREQ	300Hz ,3KHz 30KHz,300KHz 3MHz 30MHz	0.00025	3MHz/30MHz 耐用 VC5020

AMBIENT ENVIRONMENT STATION

- Temperature: 23±2°C
- Relative humidity: ≤70%RH
- Power : varied at 5% of rated voltage
- Frequency of power: rated value±1Hz
- Warmup: 2 hours for standard equipment, 1 hour for measured meter

OPERATION FOR CALIBRATOR

Calibrate the functions and ranges listed in the table 5-2.

Table 5-2. INPUT SIGNAL

Function	Range	Input 1 (First)	Input 2 (Second)	Unit
Volts dc	DC300mV	300.00		mV
	DC3V	3.0000		V
	DC30V	30.000		V
	DC300V	300.00		V
	DC1000V	1000.0		V
Volts ac	AC300mV (1KHz)	30.00	300.00	mV
	AC3V (1KHz)	0.3000	3.0000	V
	AC30V (1KHz)	3.000	30.000	V
	AC300V (50Hz)	30.00	300.00	V
	AC750V (50Hz)	75.0	750.0	V
Resistance	300Ω	300.00		Ω
	3KΩ	3.0000		KΩ
	30KΩ	30.000		KΩ
	300KΩ	300.00		KΩ
	3MΩ	3.0000		MΩ
	30MΩ	10.000		MΩ
	300MΩ	10.000		MΩ
Current dc	DC0.3mA	0.30000		mA
	DC3mA	3.0000		mA
	DC30mA	30.000		mA

	DC300mA	300.00		mA
	DC10A	3.0000		A
Current ac	AC0.3mA (1KHz)	0.03000	0.30000	mA
	AC3mA (1KHz)	0.3000	3.0000	mA
	AC30mA (1KHz)	3.000	30.000	mA
	AC300mA (1KHz)	30.00	300.00	mA
	AC10A (1KHz)	0.300	3.000	A
Frequency(3V of sine wave)	3KHz	3.0000		KHz

NOTE

To calibrator the meter, connect the instrument power cord to a power receptacle with earth ground.

DC Volts calibration

- 1) Turn on the meter, press the **DCA**, **dBm** and **▶▶▶** button simultaneity to enter calibration mode, and the “CAL” appears on the top left corner of the LCD(the “CAL” annunciator always appears in calibration mode), and the meter default enter to 300mV DC volts calibration mode.
- 2) Placed the standard equipment in the “STBY” state, and connected with the meter as shown in Figure 5-1.
- 3) Set the standard equipment to DCV, and adjust until the display reads 300mV, press the **OPR** button to output.

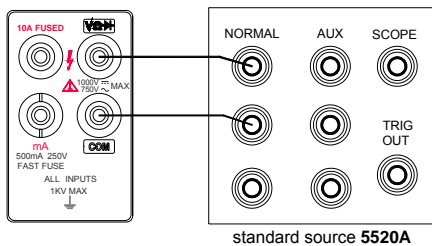

Figure 5-1

- 4) Press the **SHIFT** button of the meter to calibrate the rated range for the DCV function, and the display reads the calibrated point.
- 5) Press the **REL** button to save the calibrated value after 5 seconds, and the “SAVE” displayed on the LCD; if the “ERR” displayed, check the set value for the standard equipment, and inspect the function and the method of the

line connection right or not newly.

- 6) Press the **▲** button to change range (in calibration mode, the meter is in manual range)
- 7) Set the standard equipment to the required output.
- 8) Repeat step 4 to 7 until complete all range.

Note

Be sure that the standard equipment is in the “STBY” state before change the function.

DC 300mA amps calibration

- 1) Placed the standard equipment in the “STBY” state, press the **DCA** button and the meter default enter to 300mA DC Amps calibration state.
- 2) Connect the standard equipment with the meter as shown in Figure 5-2.
- 3) Adjust the standard equipment until the display reads 300mA, press the **OPR** button to output.

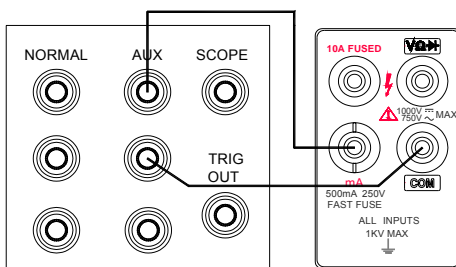

Figure 5-2

- 4) Press the **SHIFT** button of the meter to calibrate the 300mA range, and the display reads the calibrated point.
- 5) Press the **REL** button to save the calibrated value after 5 seconds, and the “SAVE” displayed on the LCD; if the “ERR” displayed, check the set value for the standard equipment, and inspect the function and the method of the line connection right or not newly

DC 10A amps calibration

- 1) Placed the standard equipment in the “STBY” state, press the **DCA** button to enter to DCA calibration state.

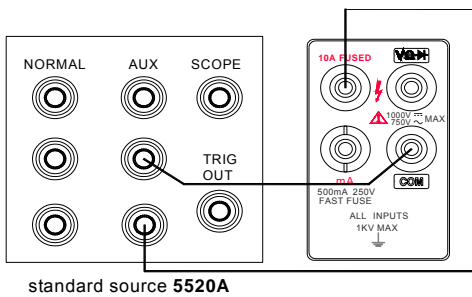

Figure 5-3

- 2) Connect the standard equipment with the meter as shown in Figure 5-3.
- 3) Press the button to select the 10A range.
- 4) Press the **SHIFT** button of the meter to calibrate the 10A range, and the display reads 3A, Applied the standard equipment 3A to the meter.
- 5) Press the **REL** button to save the calibrated value after 5 seconds, and the “SAVE” displayed on the LCD; if the “ERR” displayed, check the set value for

the standard equipment, and inspect the function and the method of the line connection right or not newly.

AC Volts calibration

- 1) Placed the standard equipment in the “STBY” state, press the **ACV** button to enter to AC Volts calibration state.
- 2) Connect the standard equipment with the meter as shown in Figure 5-1 before.
- 3) Press the **SHIFT** button of the meter enter to the 300mV range calibration.
- 4) Press the **MNMX** button of the meter, select the 30mV calibration point, and the “F” annunciator appears on the top left corner of the LCD, 1KHz appears on the secondary display indicates the frequency of the applied signal should be 1KHz.
- 5) Applied the standard equipment 30mV, 1KHz to the meter.
- 6) Keep the meter at least 20 seconds, press the **REL** button to save the calibrated value, and the “SAVE” displayed on the LCD; if the “ERR” displayed, check the set value for the standard equipment, and inspect the function and the method of the line connection right or not newly.
- 7) Press the **MNMX** button again to select the 300mV calibration point, and the “S” annunciator appears on the top left corner of the LCD, 1KHz appears on the secondary display indicates the frequency of the applied signal should be 1KHz.
- 8) Applied the standard equipment 300mV, 1KHz to the meter.
- 9) Keep the meter at least 20 seconds, press the **REL** button to save the calibrated value, and the “SAVE” displayed on the LCD; if the “ERR” displayed, check the set value for the standard equipment, and inspect the function and the method of the line connection right or not newly.
- 10) Press the button to change range.
- 11) Repeat step 3 to 10 until complete all range.

AC 30/300mA amps calibration

- 1) Placed the standard equipment in the “STBY” state, press the **ACA** button and the meter default enter to 30mA AC calibration state.
- 2) Connect the standard equipment with the meter as shown in Figure 5-2 referred before.
- 3) Press the **SHIFT** button of the meter to calibrate the 30mA range.
- 4) Press the **MNMX** button of the meter, select the 3mA calibration point, and the “F” annunciator appears on the top left corner of the LCD, 1KHz appears on the secondary display indicates the frequency of the applied signal should be 1KHz.
- 5) Applied the standard equipment 3mA, 1KHz to the meter.
- 6) Keep the meter at least 20 seconds, press the **REL** button to save the calibrated value, and the “SAVE” displayed on the LCD; if the “ERR” displayed, check the set value for the standard equipment, and inspect the function and the method of the line connection right or not newly.
- 7) Press the **MNMX** button again to select the 30mA calibration point, and the “S” annunciator appears on the top left corner of the LCD, 1KHz appears on the secondary display indicates the frequency of the applied signal should be 1KHz.
- 8) Applied the standard equipment 30mA, 1KHz to the meter.

- 9) Keep the meter at least 20 seconds, press the **REL** button to save the calibrated value, and the "SAVE" displayed on the LCD; if the "ERR" displayed, check the set value for the standard equipment, and inspect the function and the method of the line connection right or not newly.
- 10) Press the **▲** button change the range
- 11) Repeat step 3 to step 10 until complete all range.

AC 10A amps calibration

- 1) Placed the standard equipment in the "STBY" state, press the **ACA** button to enter to AC Amps calibration state.
- 2) Connect the standard equipment with the meter as shown in Figure 5-4.
- 3) Press the **▲** button to select the 10A range.
- 4) Press the **SHIFT** button of the meter to calibrate the 10A range.
- 5) Press the **MNMX** button of the meter, select the 0.3A calibration point, and the "F" annunciator appears on the top left corner of the LCD, 1KHz appears on the secondary display indicates the frequency of the applied signal should be 1 KHz.

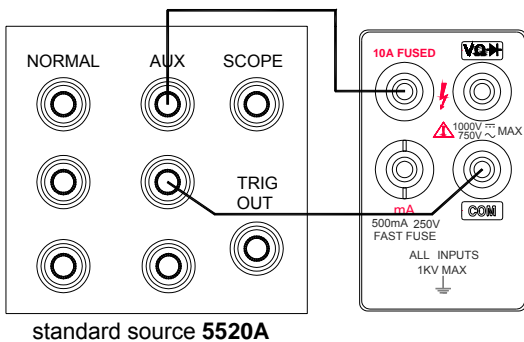

Figure 5-4

- 6) Applied the standard equipment 0.3 A, 1KHz to the meter.
- 7) Keep the meter at least 20 seconds, press the **REL** button to save the calibrated value, and the "SAVE" displayed on the LCD; if the "ERR" displayed, check the set value for the standard equipment, and inspect the function and the method of the line connection right or not newly.

- 8) Press the **MNMX** button again to select the 3A calibration point, and the "S" annunciator appears on the top left corner of the LCD, 1KHz appears on the secondary display indicates the frequency of the applied signal should be 1KHz.
- 9) Placed the standard equipment in the "STBY" state, Connect the standard equipment with the meter as shown in Figure 5-3 referred before.
- 10) Applied the standard equipment 3A, 1KHz to the meter.
- 11) Keep the meter at least 20 seconds, press the **REL** button to save the calibrated value, and the "SAVE" displayed on the LCD; if the "ERR" displayed, check the set value for the standard equipment, and inspect the function and the method of the line connection right or not newly.
- 12) Complete all range.

Frequency Calibration

- 1) Placed the standard equipment in the "STBY" state, press the **FREQ** button and the meter default enter to 3KHz range calibration state.
- 2) Connect the standard equipment with the meter as shown in Figure 5-1 referred before.
- 3) Applied the standard equipment 3V of sine wave, 3KHz to the meter.
- 4) Press the **SHIFT** button of the meter to calibrate the indicated range displayed on the meter.
- 5) Keep the meter at least 5 seconds, press the **REL** button to save the calibrated value, and the "SAVE" displayed on the LCD; if the "ERR" displayed, check the set value for the standard equipment, and inspect the function and the method of the line connection right or not newly.

Ohms calibration

- 1) Placed the standard equipment in the "STBY" state, press the **Ω** button and the meter default enter to 300Ω range calibration state.

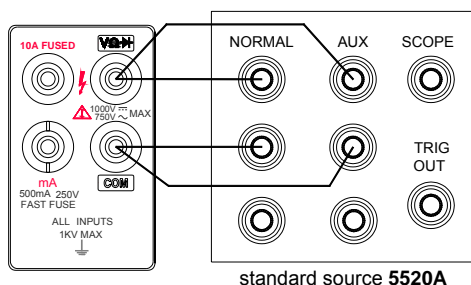



Figure 5-5

- 2) Connect the standard equipment with the meter as shown in Figure 5-5.
- 3) Applied the standard equipment 300Ω to the meter, and select 2-wire compensation on.

- 4) Press the **SHIFT** button of the meter to calibrate the indicated range displayed on the meter.
- 5) Keep the meter at least 10 seconds, press the **REL** button to save the calibrated value, and the "SAVE" displayed on the LCD; if the "ERR" displayed, check the set value for the standard equipment, and inspect the function and the method of the line connection right or not newly.
- 6) Press the  button to change rang.
- 7) Applied the standard equipment indicated on the display to the meter, once the calibrated range above 300KΩ, select 2-wire compensation on, remove the line connected with the AUX terminal of the standard equipment.
- 8) Repeat step 5 to step 7 until complete all range.

SECTION 6

Specifications

INTRODUCTION

This Section contains the specifications of the Dual Display Multimeter. These specifications assume:

- A 1-year calibration cycle
- An operating temperature of 18°C to 28°C (64.4°F~82.4°F)
- One-hour warmup
- Slow reading rate
- Relative humidity not exceeding 70% (non_condensing)

Accuracy is expressed as \pm (percentage of reading + digits).

READING RATES

Rate	Readings per Second
Slow (S)	3
Fast (F)	5~7

DC VOLTAGE

Range	Resolution	Accuracy
300mV	10uV	0.03%+3
3V	100uV	
30V	1mV	
300V	10mV	
1000V	100mV	

Input Impedance

1000MΩ at 300mV and 3V. 10MΩ at other ranges.

Normal Mode Rejection Ratio (NMR)

≥60dB (at 50Hz or 60Hz)

Common Mode Rejection Ratio (CMR)

≥120dB (at 50Hz or 60Hz)

Maximum Input

1000V peak

TRUE RMS AC VOLTAGE, AC-COUPLED

Range	Resolution	Accuracy				
		20~50Hz	50 Hz~10KHz	10~20KHz	20~30KHz	30~50KHz
300mV	10uV	2%+30	0.5%+30	1%+80	5%+80	10%+150
3V	100uV					
30V	1mV	3%+30				
300V	10mV					
750V	100mV					

REMARK: Accuracy specifications apply to the range from 10% to 100%

Input Impedance

1MΩ in parallel with 0.1μF

Maximum Crest Factor

3.0

Common Mode Rejection Ratio

>120dB at 50Hz or 60Hz (1KΩ unbalanced resistance)

Maximum Input

750V rms, 1000V peak.

DC CURRENT

Range	Resolution	Accuracy	Input Impedance
300 mA	10uA	0.1%+3	1Ω
10A	1 mA	1.5%+3	0.01Ω

Maximum Input

300mA. Protected with a 500mA, 250V fast blow fuse; 10A. Protected with a 11A, 250V fast blow fuse. for 30 seconds maximum.

TRUE RMS AC VOLTAGE, AC-COUPLED

Range	Resolution	Accuracy				
		20~50Hz	50 Hz ~2KHz	2~10 KHz	10~20 KHz	20~30 KHz
300mA	10uA	2%+30	0.5%+30		1%+80	5%+50
10A	1mA		1.5%+30	3%+30*		

“*” indicates that the range for frequency between 2~5KHz

Maximum Input

300mA. Protected with a 500mA, 250V fast blow fuse; 10A. Protected with a 11A, 250V fast blow fuse. for 30 seconds maximum.

Maximum Crest Factor

3.0

OMH

Range	Resolution	Accuracy	Open Circuit Voltage	Short Circuit Current
300Ω	10mΩ	0.05%+3	2.5V	About 1mA
3KΩ	100 mΩ			
30 KΩ	1Ω			About 250uA
300 KΩ	10Ω			About 25uA
3 MΩ	100Ω	0.1%+3		About 2.5uA
30MΩ	1 KΩ	0.2%+3		About 0.25uA
100MΩ	1 00KΩ	0.5%+3		About 0.25uA

Maximum Input Voltage

250V dc or rms ac on all ranges

DIODE TEST/CONTINUITY**Maximum Test Voltage**

≤2V

Test Current

Approximate 1mA when measuring forward bias junction.

Continuous Resistance

≤150Ω

FREQUENCY

Range	Resolution	Accuracy
300Hz	0.01 Hz	0.05%+2
3KHz	0.1 Hz	
30KHz	1 Hz	
300KHz	10 Hz	
3MHz	100 Hz	
30MHz	1KHz	

Frequency Range

10Hz to 30MHz

Applicable Function

Volts AC

Sensitivity of AC Voltage

FREQUENCY	LEVEL (SINE WAVE)
10Hz~300KHz	> 300mV
300KHz ~30MHz	> 1.5V

ENVIRONMENTAL**Temperature Coefficient**

<0.1 times the applicable accuracy specification per degree C for 5°C to 18°C and 28°C to 40°C.

Operating Temperature

5°C to 40°C

Storage Temperature

-25°C to 50°C

Relative Humidity	≤90% at 5°C to 28°C (non-condensing)
	≤80% at 28°C to 40°C
	≤70% at 10°C to 40°C for the 300KΩ, 3MΩ and 30MΩ ranges.

GENERAL

Common Mode Voltage	1000V dc or peak ac maximum from any input to earth
Size	245mm deep, 220mm wide, 82mm high
Weight	about 2Kg
Power	about 5VA

ACCESSORIES

- A couple of test leads
- A power line cord
- A user's manual

SECTION 7

Points for Attention to Use of Operation Instruction

- The present operation instruction is subject to change without notice.
- The content of the operation instruction is regarded as correct. Whenever any user finds its mistakes, omission, etc., he or she is requested to contact the manufacturer.
- The present manufacturer is not liable for any accident and hazard arising from any maoperation.
- The functions described in this operation instruction should not be used as grounds to apply this product to a particular purpose.



Imported to Sweden by Electrokit Sweden AB