

1、 Features:

- Emitting Color: White
- Lens Type: Yellow Diffused
- Device Outline: 5.0x5.0x1.5 (unit:mm)
- RoHS compliant

2、 Applications:

- Backlight for Mobile, Machine Vision, LCD Display
- Backlight in Dashboard and switch of Automive
- Indoor LED lighting, Architectural Lighting

3、 Outline Dimensions:

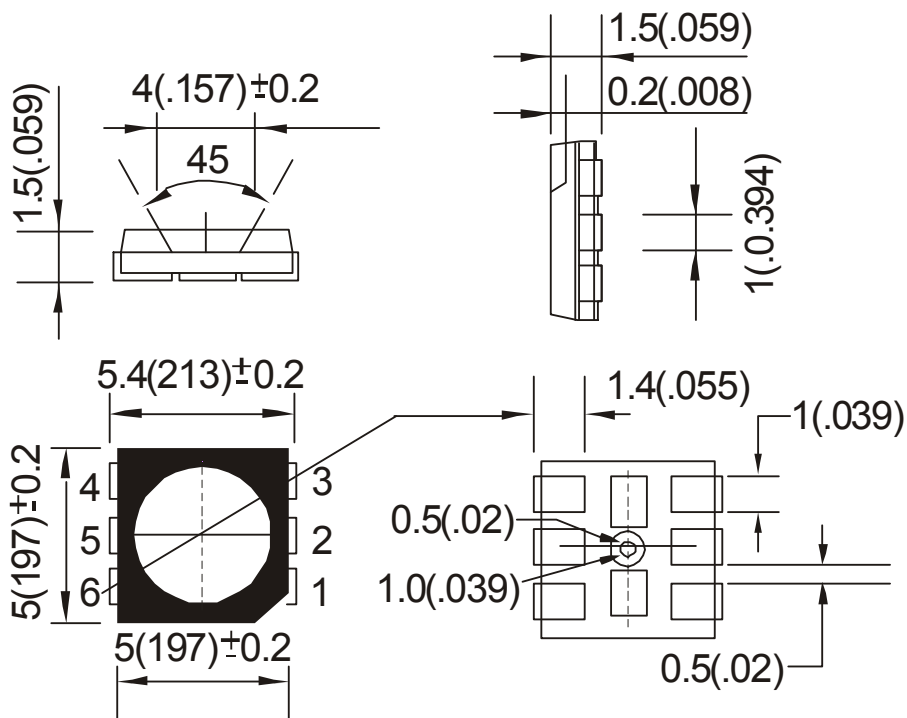



4、 Absolute maximum ratings (Ta = 25°C):

Parameter	Symbol	Test Condition	Value		Unit
			Min.	Max.	
Power Dissipation	Pd	—	—	255	mW
Reverse Voltage	VR	IR = 30 μA	5	—	V
Pulse Current	IFp	Duty=0.1, 1kHz	—	100	mA
Forward Current	IFm	—	—	25	mA
Operating Temperature	Topr	—	-40	+85	°C
Storage Temperature	Tstr	—	-40	+100	°C

5、 Electrical and optical characteristics (Ta = 25°C):

Parameter	Symbol	Test Condition	Value			Unit
			Min.	Typ.	Max.	
Forward Voltage	VF	IF = 60mA	3.0	3.2	3.6	V
Reverse Current	IR	VR = 5V	—	—	30	μA
Color Temperature	Tc	IF = 60mA	—	6000	—	K
Luminous Intensity	Iv	IF = 60mA	4200	6200	—	mcd
Luminous Flux	Iv	IF = 60mA	19	21	23	lm
Color Rendering index	Ra	IF = 60mA	70	—	—	—
Viewing Angle	2 θ 1/2	IF = 60mA	—	120	—	Deg.

Part No.: JSL-5050UWC

6、Typical electrical/optical characteristic curves/光电特性曲线:

