

Part No.: JSL-532RGBC-S

Features:

- RGB color
- Slowly Blinking
- High bright output
- Low power consumption
- High reliability and long life

Descriptions:

- Dice material: AlGaInP
- Emitting Color: Super Bright RGB,blinking
- Device Outline: ϕ 5mm Round Type
- Lens Type: Water Clear

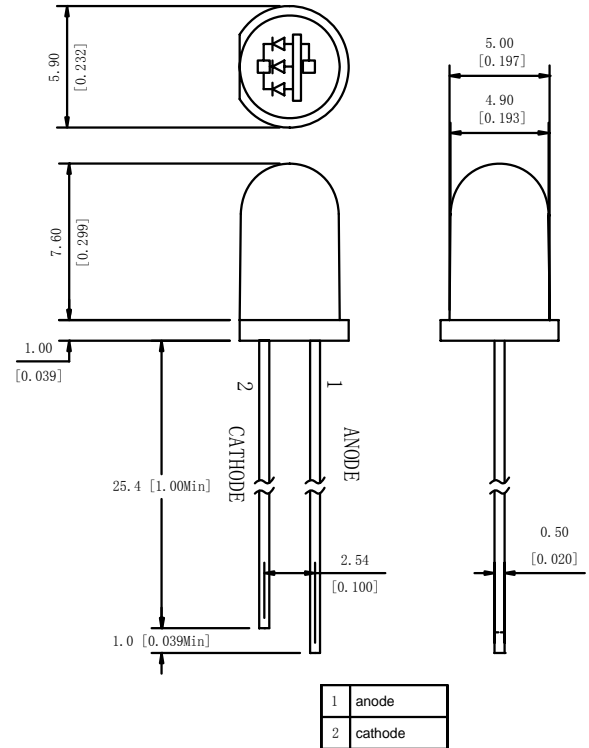

Directivity:

1. All dimensions are millimeters
2. Tolerance is +/-0.20mm unless otherwise noted

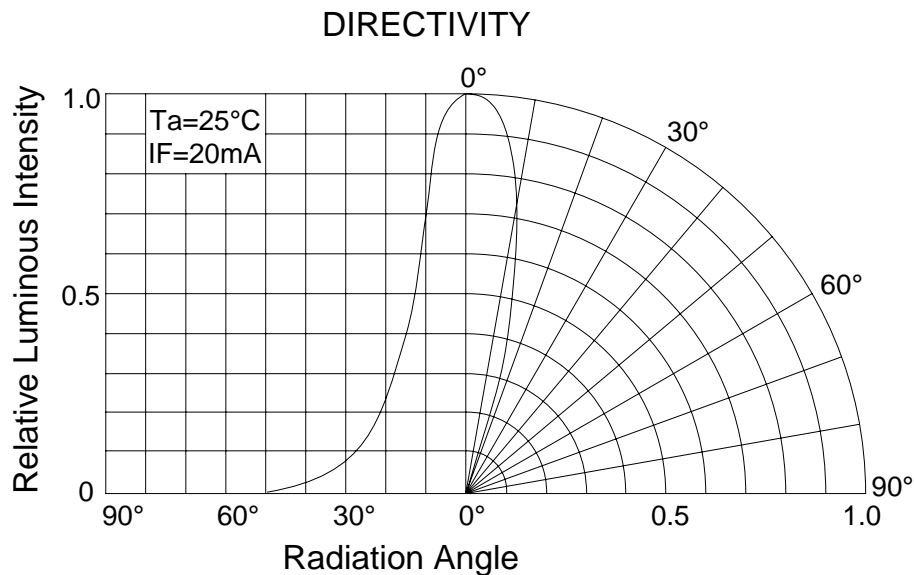

Part No.: JSL-532RGBC-S

4、 Absolute maximum ratings (Ta = 25°C):

Parameter	Color	Symbol	Test Condition	Value		Unit
				Min.	Max.	
Power Dissipation	Red	Pd	—	—	75	mW
	Green				120	
	Blue				120	
Reverse Voltage	—	VR	IR = 30 μ A	5	—	V
Pulse Current	—	IFp	Duty=0.1, 1kHz	—	100	mA
Forward Current	—	IFm	—	—	25	mA
Operating Temperature	—	Topr	—	-40	+80	°C
Storage Temperature	—	Tstr	—	-40	+85	°C

5、 Electrical and optical characteristics (Ta = 25°C):

Parameter	Color	Symbol	Test Condition	Value			Unit
				Min.	Typ.	Max.	
Forward Voltage	Red	VF	IF = 20mA	1.8	—	2.5	V
	Green			2.8	—	3.5	
	Blue			2.8	—	3.5	
Reverse Current	—	IR	VR = 5V	—	—	30	μ A
Wavelength	Red	Tc	IF = 20mA	620	—	635	nm
	Green			520	—	530	
	Blue			460	—	470	
Luminous Intensity	Red	Iv	IF = 20mA	1200	1500	—	mcd
	Green			1500	4000	—	
	Blue			1300	1600	—	
Viewing Angle	—	2 θ 1/2	IF = 20mA	—	30	—	Deg.

Part No.: JSL-532RGBC-S

6. Typical photoelectricity characteristic curve chart

