

# A028 BALANCE MICROPHONE PRE-AMPLIFIER

Go from either dynamic condenser or electret microphone to line-level with a minimum of noise, distortion and hassle. Balance Microphone preamplifier is ultra clean one channel preamplifier, intended for use in most critical digital analog recording situations. The kit delivers exceptional sonic performance even with extremely high input levels, making it ideal mate to the latest generation of transformer less condenser Microphones. Built around well know pro audio preamplifier IC, very low noise and distortion kit offers 40dB overall gain variation, from 20dB to 60dB on board DC servo feedback and Balance audio output driver. All condenser Microphone require some kind of electrical power and this power call phantom, kit has facility for phantom power input and on board switch to turn on and off. The phantom power term means a positive DC voltage sent to the microphone on both audio leads through current limiting resistors.

- Supply dual 15V DC @ 500mA
- Trimpot for Audio gain adjust 20dB-60dB
- Frequency response 20Hz-20KHz
- Maximum input +13dBV
- Input impedance greater then 3K Ohms
- DC servo feedback
- Balance driver IC for balance audio output
- Berg connector for unbalance audio out
- Berg connector for phantom power input 48V @ 20mA
- Slide switch for phantom power On/Off
- RFI/EMI filter in input and output
- Female XLR for Microphone input
- Male XLR for Balance audio output
- Berg connector for supply input
- Berg connector Aux audio out and dual supply for VU meter
- Four mounting holes of 3.2 mm each
- PCB dimensions 85 mm x 59 mm

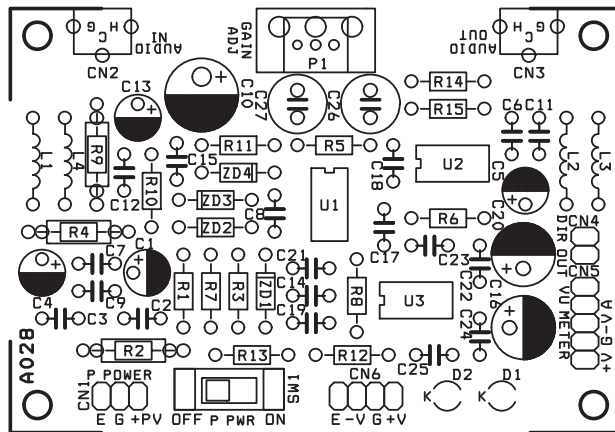

- CN1 Connector : Phantom Power Supply 48 VDC
- CN2 Connector : Audio Signal Input, Balance
- CN3 Connector : Audio Signal Output, Balance
- CN4 Connector : Direct Output, Unbalance Audio Signal Output
- CN5 Connector : VU Meter
- CN6 Connector : Dual Supply 15 VDC
- D1, D2 LED : Power Indication
- P1 Pot/Preset : Audio Gain Adjust

SR.	QTY.	REFERENCE	DESCRIPTION
1	1	CN1	3 PIN BERG CONNECTOR
2	1	CN2	3 PIN XLR FEMALE CONNECTOR
3	1	CN3	3 PIN XLR MALE CONNECTOR
4	1	CN4	2 PIN BERG CONNECTOR
5	1	CN5	5 PIN BERG CONNECTOR
6	1	CN6	4 PIN BERG CONNECTOR
7	3	C1,C4,C13	47uF/63V
8	8	C2,C14,C17,C18,C19,C21,C22,C23	0.1uF
9	2	C3,C15	1uF
10	1	C5	100uF/50V
11	3	C6,C11,C25	470pF
12	2	C7,C12	1nF
13	2	C8,C9	220pF
14	1	C10	470uF/25V
15	2	C16,C20	220uF/25V
16	1	C24	JUMPER WIRE
17	2	C26,C27	10uF/50V NON POLARIZED
18	1	D1	RED LED 3MM
19	1	D2	GREEN LED 3MM
20	4	L1,L2,L3,L4	1uH
21	1	P1	2K POTENTIOMETER/PRESET
22	1	R1	47K
23	1	R2	100E, 1/2W
24	2	R3,R11	100E
25	2	R4,R9	6.8K, 1/2W
26	1	R5	10E
27	1	R6	52E OR 51E
28	2	R7,R10	20K
29	1	R8	510K
30	2	R12,R13	1.5K
31	2	R14,R15	56K
32	1	SW1	SLIDE SWITCH
33	1	U1	SSM2019/THAT1510/THAT1512
34	1	U2	SSM2142/DRV134/THAT1646
35	1	U3	LF351
36	4	ZD1,ZD2,ZD3,ZD4	1N5232, 5.6V ZENER DIODE
37	3	SOCKET	8 PIN DIP IC SOCKET

