

A025 High-End 20W Stereo Amplifier

Kits has been design around LM1875 IC from National. Kit is truly professional amplifier clean, crispy sound reproduction and total freedom from noise, its deliver 20W + 20W RMS into 8 Ohms @ less then 1% THD (Greater then 0.06%) THD @ 1KHz in 1W with 8Ohms Load. Can be use as recording and broadcast studio near field monitor amp, audio monitor in studios, paging system power amplifier, back ground music amplifier. IC shall be protected from output short circuit. Frequency response 20Hz to 20KHz circuit also include DC servo feedback. Also recommended Balance audio preamplifier (Buffer/driver) A027 Kit for balance audio input perfect match for Balance input Pro-Audio amplifier.

Heat sink is not provided with kit buy separately N002 from Accessories.

- Supply Dual (+/-) 25 VDC @ 2 Amp
- Onboard +/- 15 VDC Regulator for Balance preamplifier or also can be use as Aux power for VU meter or MIC preamplifier
- Onboard dual LED for power indication
- Audio input via berg connector
- Berg connector for VU Meter L-R and +/-15 V supply also can be use for head phone
- Screw terminal connector for speaker connection
- Screw terminal connector for Supply +/- 25 VDC
- Gain 27dB
- THD+noise less then 1% @ 20W into 8 Ohms

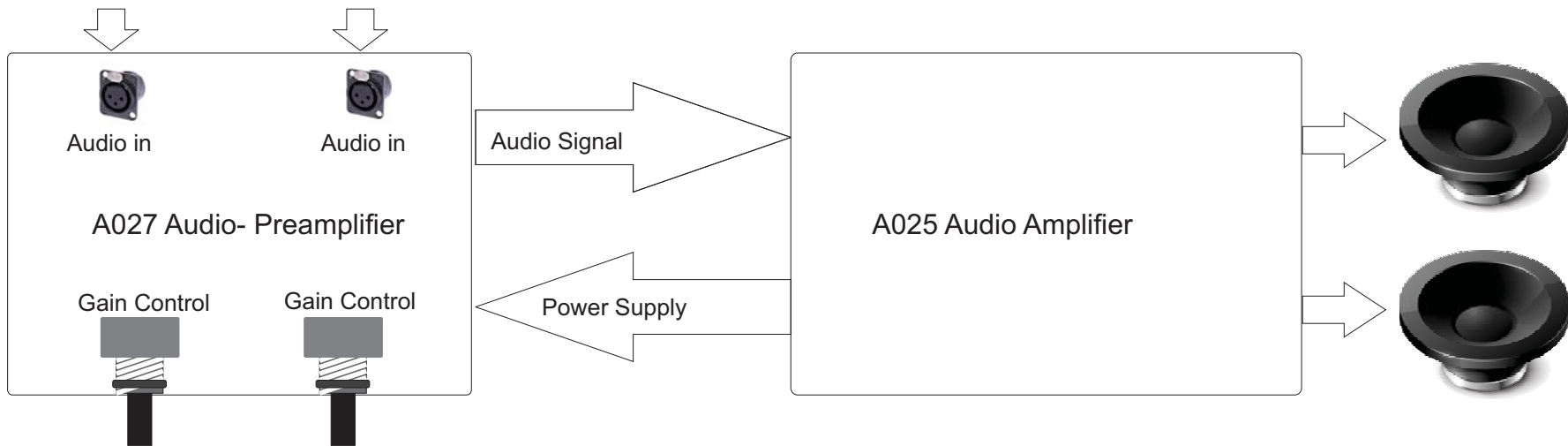
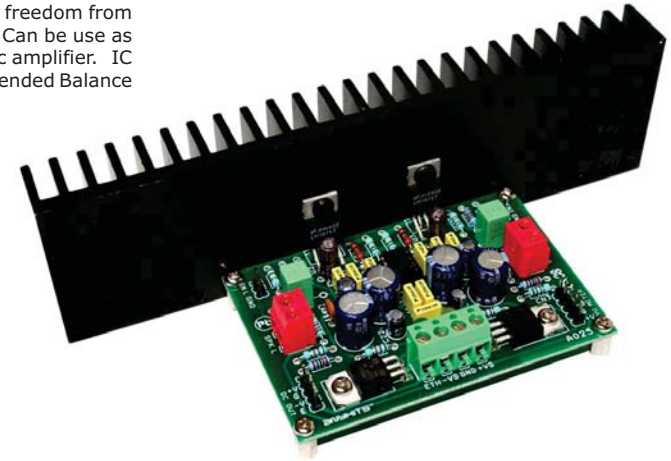



SR	QTY	REFERENCE	DESCRIPTION
1	1	CN1	2 PIN BERG CONNECTOR
2	1	CN2	2 PIN BERG CONNECTOR
3	1	CN3	5 PIN BERG CONNECTOR
4	1	CN4	4 PIN SCREW TERMINAL CONNECTOR
5	1	CN5	4 PIN BERG CONNECTOR
6	2	C1,C2	4.7KpF/4.7nF
7	2	C3,C4	2.2uF
8	2	C5,C6	47pF
9	2	C7,C8	0.22uF/220nF
10	2	C9,C10	47uF/25V
11	4	C11,C13,C17,C19	220uF/35V
12	7	C12,C14,C15,C18,C20,C21,C23	0.1uF
13	2	C16,C22	10uF/50V or 63V
14	2	D1,D2	RED LED
15	1	LS1	2 PIN SCREW TERMINAL CONNECTOR
16	1	LS2	2 PIN SCREW TERMINAL CONNECTOR
17	4	R1,R2,R3,R4	100K
18	4	R5,R7,R10,R12	20K
19	2	R6,R8	1.2E, 0.5W
20	6	R9,R11,R13,R15,R17,R18	1.2K
21	2	R14,R16	2.2K
22	1	U1	LF353
23	2	U2,U3	LM1875
24	1	U4	LM7815
25	1	U5	LM7915
26	1	DIP Socket	8 PIN DIP SOCKET
27	2	Screw Set	2 SCREW FOR 7805/7905

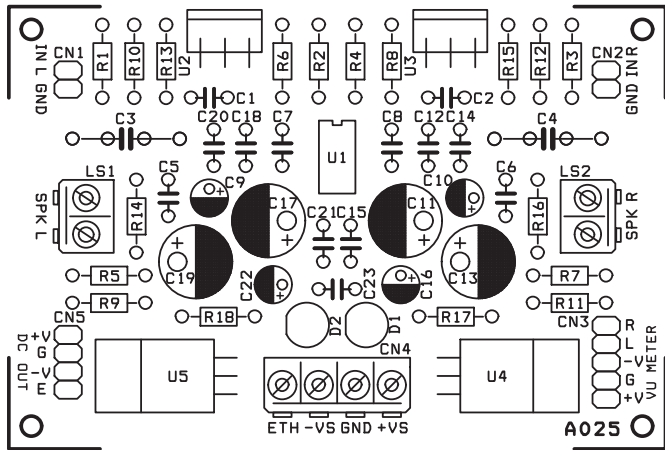
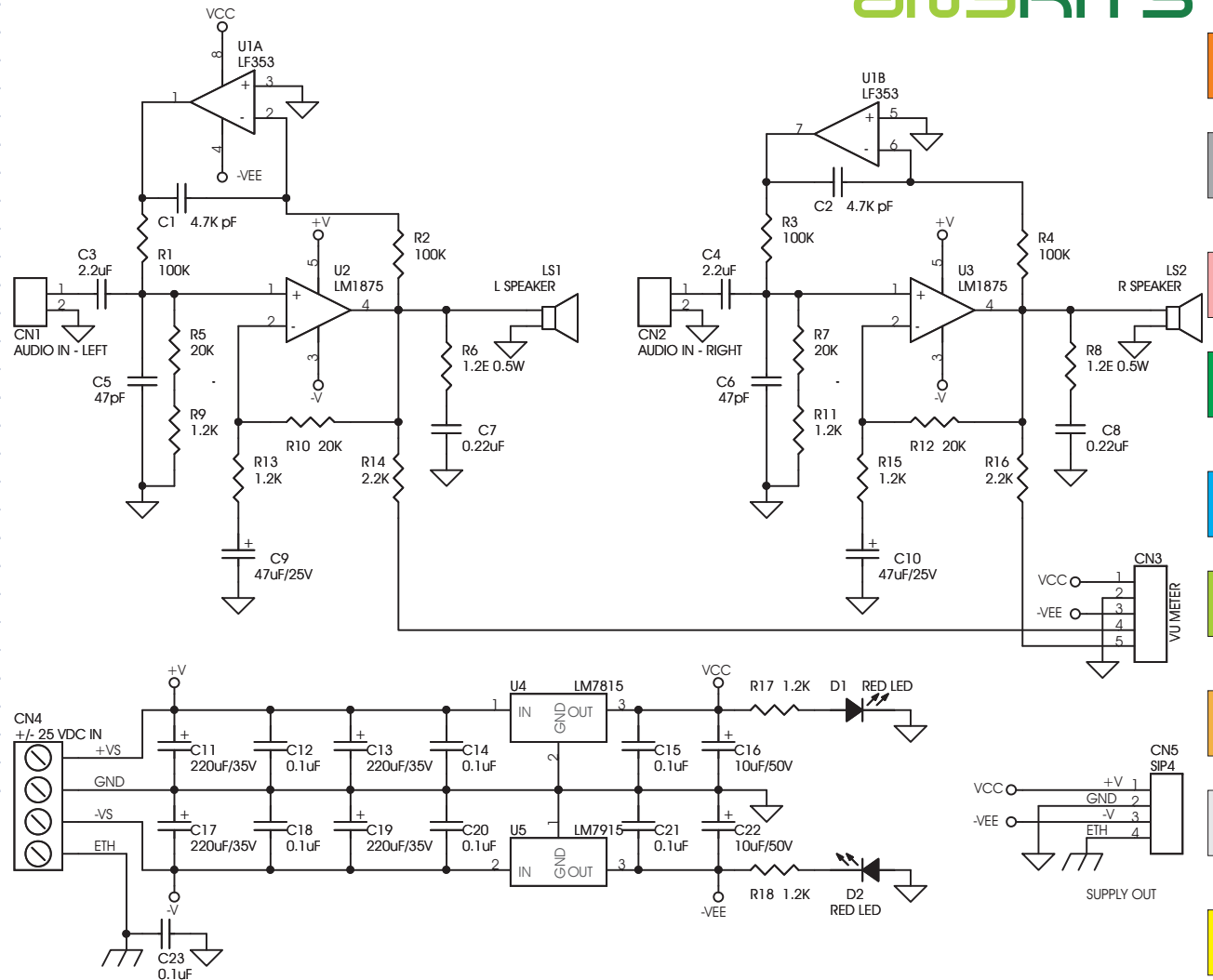

CN1	Audio Input Left Channel
CN2	Audio Input Right Channel
LS1	Left Speaker
LS2	Right Speaker
CN3	VU Meter Out
CN4	DC Supply for Amplifier Dual 25 VDC
CN5	Dual 15 VDC out for Pre-Amp