

3 POINTS INFRARED SENSOR BOARD
CODE 1111S LEVEL 3

This 3 points infrared super sumo sensor can be used with FK1111 PIC1 obstacle-avoiding robot. It has 3 sets (left set, right set and center set), in set as transmitter and receiver of infrared light. The user can be used with the other application.

Technical Specifications:

- Power supply : 3-6VDC.
- Consumption : 20mA. @ 6VDC.
- PCB dimensions : 2.54 x 1.18 in.

How To Work:

Sensor board as shown in Fig. 1 have 3 sets, in set as transmitter and receiver of infrared light. Transmitter part is consist TR4 and LED INF. VR4 is used for adjust the level of infrared light. Receiver part, when photo-transistor received infrared light from LED INF, causing voltage being passed through. The more reflected light will lessen the internal resistance and give bigger passing through voltage. Less reflected light will enlarge the internal resistance and give less passing through voltage. TR1 to TR3 will work when the photo-transistor received infrared light.

Circuit Assembling:

The SENSOR1-1 circuit assembling has been shown in

Fig 2. It is recommended to assemble the circuit starting with a less height component i.e. diodes, resistor, electrolytic capacitors and transistors etc. Be careful while assembling and check for the matching of PCB poles and components before soldering as shown in Fig 3. For IDE port, press the pin of IDE port to be level with the black plastic before soldering. Use a max. 40W solder and soldering tin with a tin and lead ratio of 60/40 together with a joint solution inside. Recheck the assembled circuit for your own confidence. Better use a lead sucker or a lead wire absorber in case of component misplacing to protect PCB from damage.

Testing:

When the sensor boards have been completely assembled, Install this board and insert the control board FK1111C to robot body. Insert four AA batteries into the battery holder. Then adjust all trimpot to the middle side and slide switch SW to "on" position. LED at sensor board is lighted on. Lay down the assembled robot on the box. When any sensor detects bar, The robot will avoid the bar and running the other way.

VR1, VR2 and VR3 will act as sensitivity of photo-transistor. Adjust to the left hand side for decreasing sensitivity and to the right hand side for increasing sensitivity. VR4 will act as level of infrared light. SW1 is not used.

NOTE: In case of if you want to use the other application, you have to connect R pull-up 10kΩ at the collector of TR1 and TR3 before using.

Figure 2. SENSOR1-1 Circuit Board Assembling

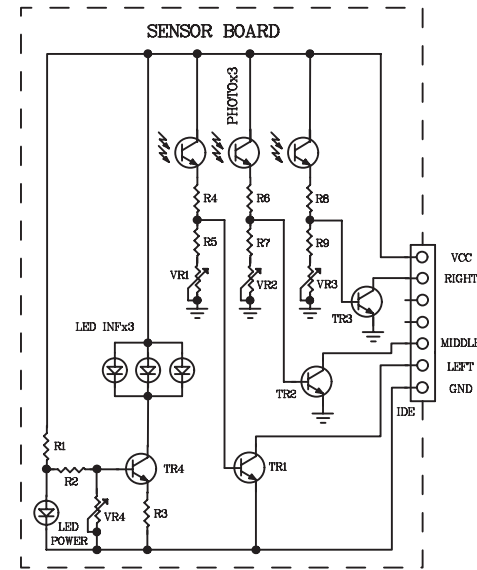
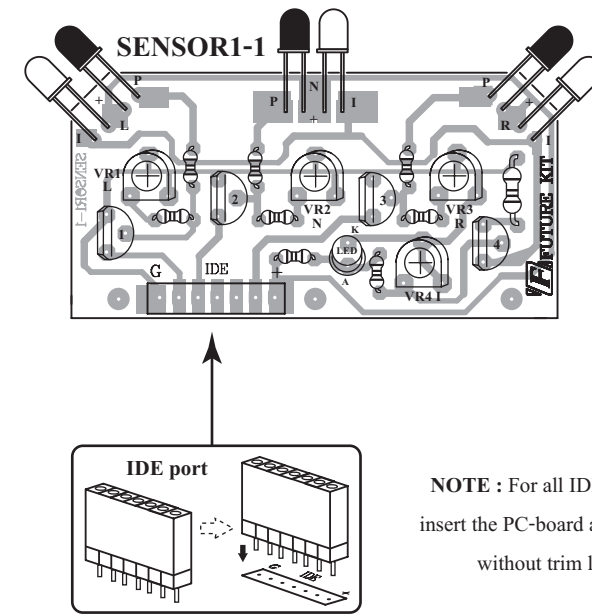
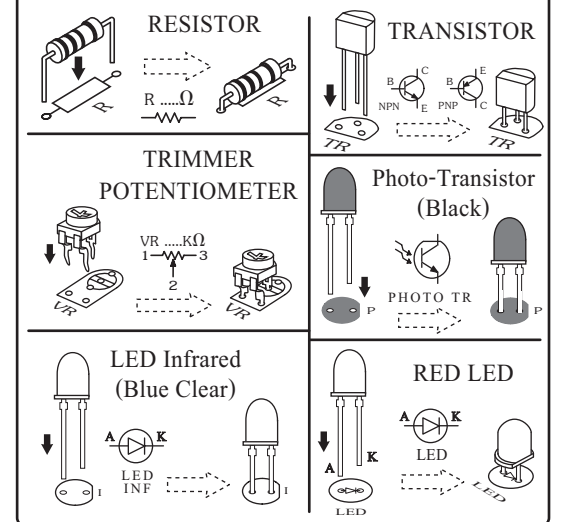

Figure 1.
3 points Infrared Sensor Board Circuit

Figure 3. Components Installing



Troubleshooting:

As the circuit has only a few components, the main cause of troubles will come from component misplacing and defaulted soldering. When found out that the circuit does not work, check for the proper component placings and various soldering points.