

AVR2 OBSTACLE-AVOIDING ROBOT CONTROLLER  
CODE 1110C LEVEL 3

This robot will start moving whenever the sensor detects any obstacles and can avoid them. With its built-in AVR microcontroller. The user can re-write any program for getting new applications.

**Technical Specifications:**

- Power supply : 2 AA batteries (not included).
- Consumption : 6mA. @ 3VDC. (no load).
- PCB dimensions : 2.54 x 2.70 in.

**(1) ROBOT CONTROL CIRCUIT**

**How To Work:**

The circuit is composed of 2 major parts, sensor board (optional code FK1110S) and control board, as shown in Fig. 1.

Sensor board have 2 sets, in set as transmitter and receiver of infrared light. Transmitter part is consist TR2 and LED INF. VR3 is used for adjust the level of infrared light. Receiver part, when photo-transistor received infrared light from LED INF, causing voltage being passed through. The more reflected light will lessen the internal resistance and give bigger passing through voltage. Less reflected light will enlarge the internal resistance and give less passing through voltage. TR1 and TR3 will work when the photo-transistor received infrared light.

Control board, at the heart of the circuit is the AVR microcontroller IC1. When photo-transistor is not receiving infrared light, TR1 and TR3 are not working. IC1 will send the voltage to pin 12 and pin 15, causing both motor is running

forward. If some photo-transistor received infrared light, motor is running backward. IDE port is used for connect AVR programmer.

**Circuit Assembling:**

The AVR2-2 circuit assembling has been shown in Fig 2. It is recommended to assemble the circuit starting with a less height component i.e. diodes, resistor, electrolytic capacitors and transistors etc. Be careful while assembling and check for the matching of PCB poles and components before soldering as shown in Fig 3. For IDE port, press the pin of IDE port to be level with the black plastic before soldering. Use a max. 40W solder and soldering tin with a tin and lead ratio of 60/40 together with a joint solution inside. Recheck the assembled circuit for your own confidence. Better use a lead sucker or a lead wire absorber in case of component misplacing to protect PCB from damage.

**Testing:**

When the control board have been completely assembled, jump J2 and not jump J1. Insert the control circuit board into robot body and two AA batteries into the battery holder. Then adjust VR1, VR2 and VR3 to the middle side and slide switch SW to "on" position. LED at sensor board is lighted on. Lay down the assembled robot on the box. When any sensor detects bar, The robot will avoid the bar and running the other way.

VR1 and VR2 will act as sensitivity of photo-transistor. Adjust VR1 and VR2 to the left hand side for decreasing sensitivity and to the right hand side for increasing sensitivity. VR3 will act as level of infrared light. SW1 is not used.

**Troubleshooting:**

As the circuit has only a few components, the main cause of troubles will come from component misplacing and defaulted soldering. When found out that the circuit does not work, check for the proper component placings and various soldering points.

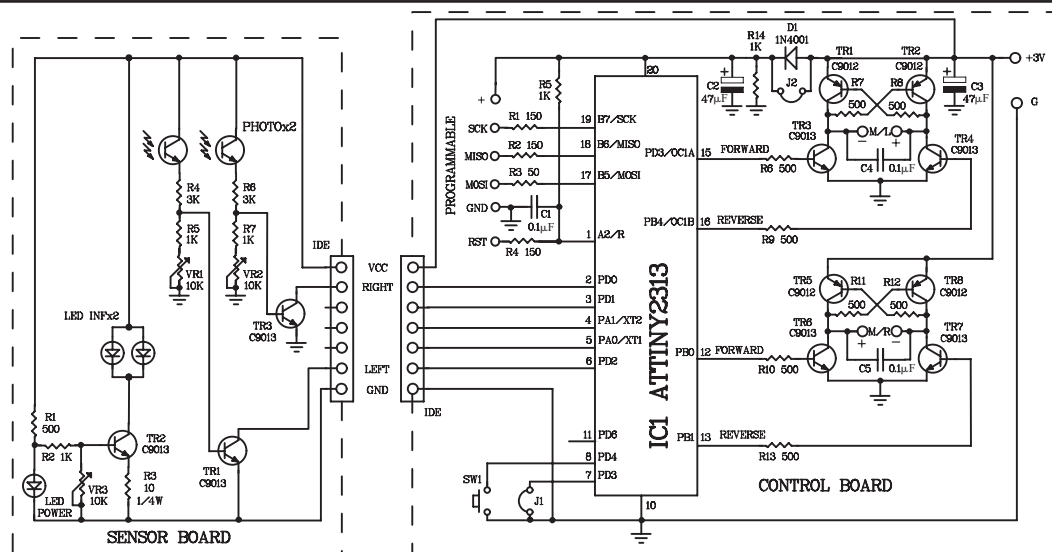
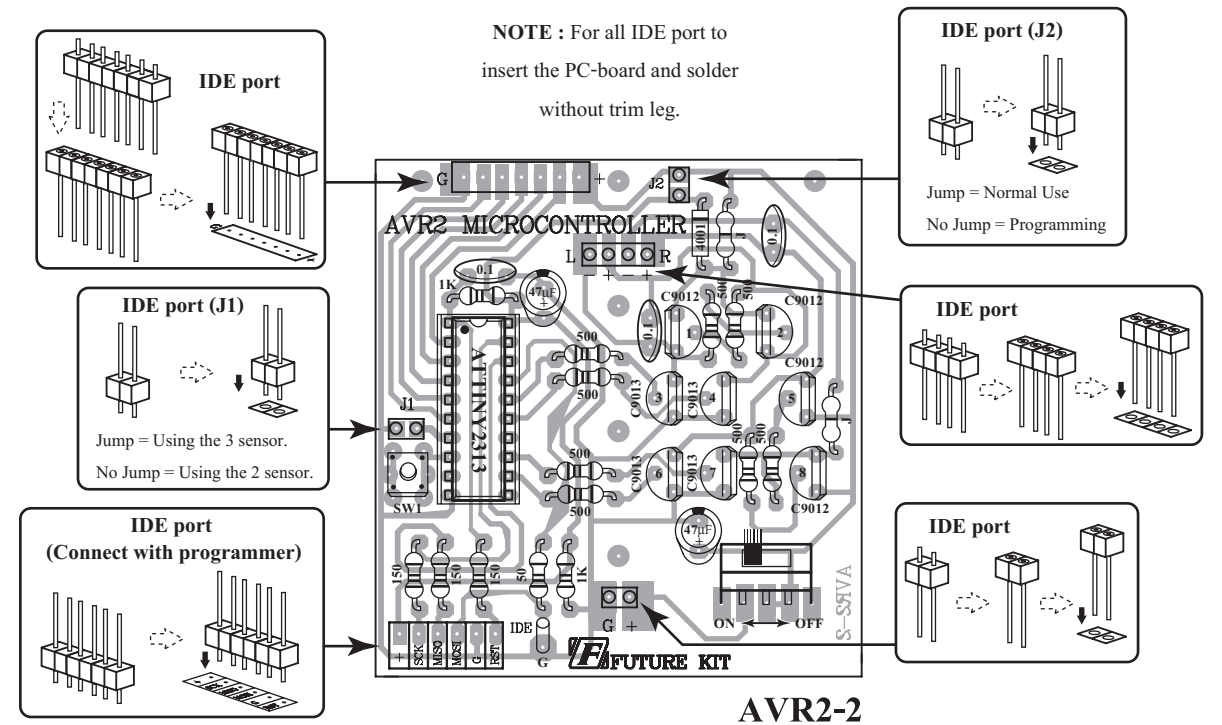

Figure 1. AVR2 Obstacle-Avoiding Robot Controller Circuit

Figure 2. AVR2-2 Circuit Board Assembling



**NOTE:** Jumper J1, If jumping this point is using 2 sensor (left and right side) but if no jumping this point is using 3 sensor (left, right and front side).

**CONTROL BOARD**

**RESISTORS 1/4W**

- R1,R2,R4 150Ω - brown-green-brown-gold
- R3 50Ω - green-black-black-gold
- R5,R14 1kΩ - brown-black-red-gold
- R6-R13 500Ω - green-black-brown-gold

**CERAMIC CAPACITORS**

- C1,C4,C5 = 0.1μF or 104

**ELECTROLYTIC CAPACITORS**

- C2-C3 = 47μF

**TRANSISTORS**

- TR1,TR2,TR5,TR8 = C9012
- TR3,TR4,TR6,TR7 = C9013

- DIODE D1 = 1N4001

- IC IC1 = ATTINY2313

Figure 3. Components Installing

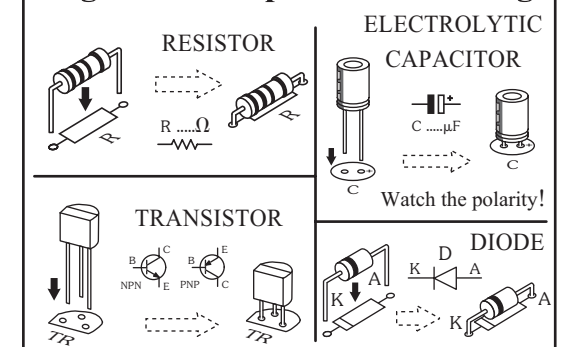

**NOTE:** This circuit has the control board only. For the sensor board and body robot aren't included.