

POWER AMP 2+2 W STEREO
CODE 675 **LEVEL 1**

This power amplifier circuit is the small amplifying circuit that suitable for sound a bout signal amplifying.

Technical specifications:

- power supply : 9-12VDC.
- consumption : 600mA.max. (8Ω loudspeaker, 0.25W @12VDC).
- output power : 2W.max. (8Ω loudspeaker, 2W@12VDC, 3A. max.)
- adjust. level sound by trimmer potentiometer.
- S/N ratio : 80dB (A weighted)
- frequency response : 20Hz to 20kHz (-3dB)
- PCB dimensions : 2.22 x 1.89 inches.

How to works:

As shown in figure, there is L side, R side is the same as L side. The following explanation is applicable for both side. Signal from INPUT will pass C1 and VR1 to adjust sound signal. Signal at the middle pin of volume will pass to pin 3 and amplify signal to pin 5. The amplified signal will then pass C8 to coupling signal toward the speaker to pin of IC. R1, C2 are connected to ground for controlling the amplifying function. Pin 7 acts as boostap. R3, C7 incharge for high frequency oscillated prevention.

PCB assembly:

Shown in Figure 3 is the assembled PCB. Starting with the lowest height components first, taking care not to short any tracks or touch the edge connector with solder. Some tracks run under components, and care should be taken not to short out these tracks. If the pins will not enter the holes with ease, use a small drill to slightly enlarge the opening. All components with axial leads should be carefully bent to fit the position on the PCB and then soldered into place. Make sure that the electrolytic capacitors are inserted the correct way around. Some components are particularly sensitive to heat (ie: Transistors, IC's, diodes etc.) extra care must be taken to only apply the iron for as little time as possible, using a pair of pliers to grip the leads will help conduct heat away. Trim components leads with wire cutters to prevent excess lengths causing a short circuit. Now check that you really did mount them all the right way round!

Testing:

Installing according to the figure, turning the trimmer potentiometer to max. counterclockwise. Taking input signal (either L or R sides) from tape or radio by connecting at PHONE point. If it is mono signal, firstly testing L or R side. Speaker (4" 2 watts minimum) and power supply using 9-12 volts rate 600mA minimum. After finish the installation, increasing volume of variable resistor by turning to MAX, speaker sound would louder. If increasing the volume but the sound is not clear, means input signal is too strong and should be decreased.

NOTE: If you want to increase the level and quality of sound to put loudspeaker into the speaker box.

Figure 1. Installing the componants

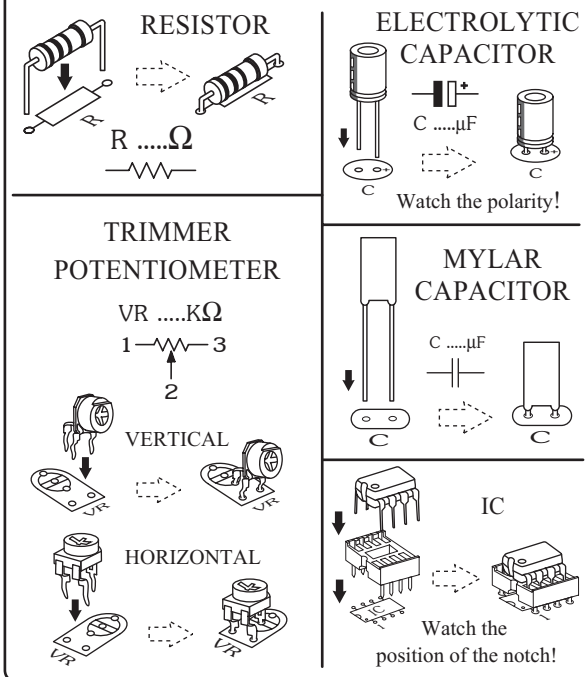

Troubleshooting:

The most problem like the fault soldering. Check all the soldering joint suspicious. If you discover the short track or the short soldering joint, re-solder at that point and check other the soldering joint. Check the position of all component on the PCB. See that there are no components missing or inserted in the wrong places. Make sure that all the polarised components have been soldered the right way round.

Figure 2. The power amp 2+2W. stereo circuit

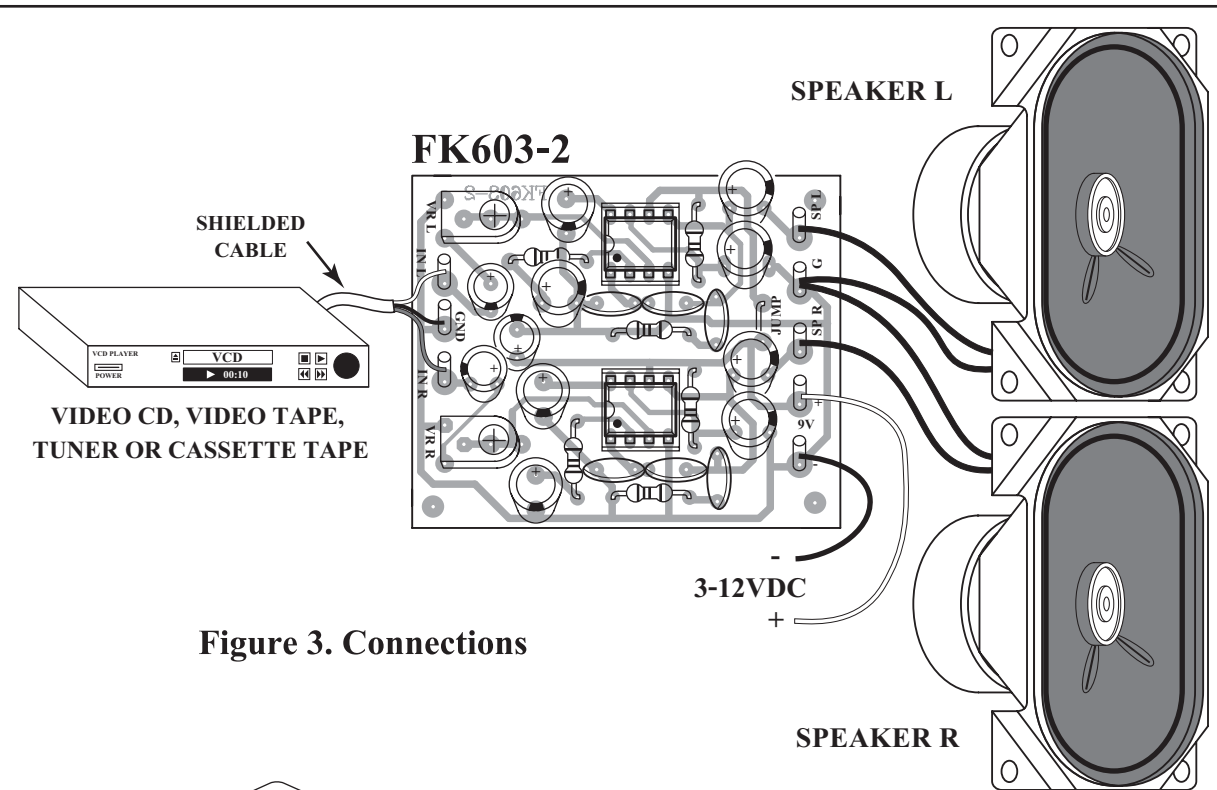
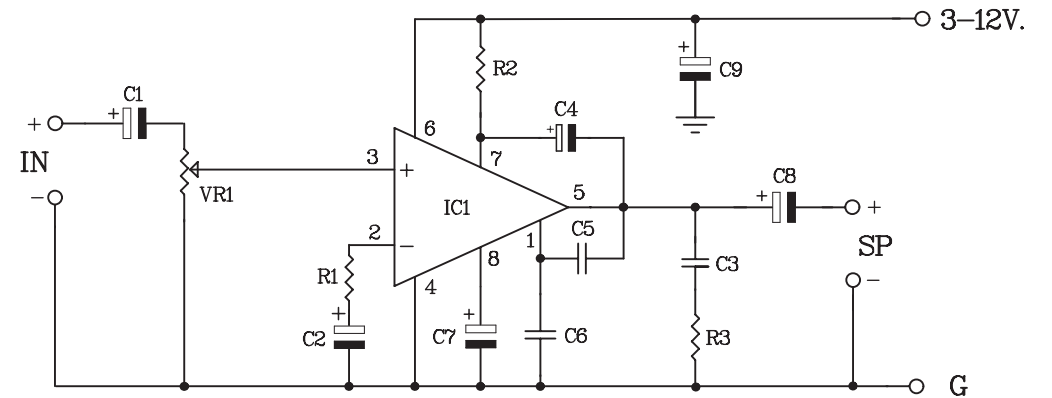
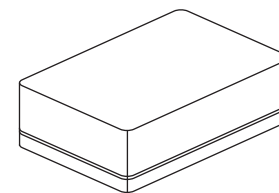

Figure 3. Connections



NOTE:
FUTURE BOX FB03 is suitable for this kit.

NEW KIT SET **NEW**

CODE FK	DESCRIPTION	POWER
511	TWO FUNCTION INFRARED SENSOR	12VDC
674	POWER AMP. 2W MONO WITH SPEAKER	9-12VDC
675	POWER AMP. 2+2W STEREO WITH SPEAKER	9-12VDC