

SOUND ACTIVATED XENON TUBE FLASHER
CODE 139 **LEVEL 2**

This circuit is the flashing light circuit. Whenever there is any sound, the circuit will work, and if the any sound stops, the circuit will not work.

Technical specifications:

- power supply: 220-240VAC.
- flash-tube use light output of the electrical energy : 3 watts/second.
- adjustable sensitivity of detect the sound with potentiometer.
- There is the switch start point for test the circuit.
- PCB dimensions : 1.99 x 2.97 inch.

How to works:

The AC line 220-volt is then half-wave rectified by D1. The DC voltage is divided into two parts. The part one is fed through R2 and charged to electrolytic capacitor C1 for drive the xenon tube. This voltage is fed to R3, and charged to C2, and the NEON is light on. The part two is fed through R1 to the signal amplifier with have ZD1 is a regulated 10-volt. The dynamic buzzer is used to the sound detector. TR1 is a amplifier the signal, and fed to C3 and VR1. VR1 is adjusted to sensitivity of the dynamic buzzer for trigger to the gate of SCR1.

When is any sound, the dynamic buzzer will detect the signal. This the signal is fed to TR1. The TR1 is a amplifier the signal for trigger the gate of SCR1 with fed to C3, VR1 and R6, SCR1 will work, and the voltage at the anode of SCR1 is fed to the ground. The on/off action of SCR1, caused by the pulsating signal applied to it, creates a rising and collapsing field in the primary winding of T1. That causes a pulsating signal, of opposite porality, to be induced in T1's secondary winding. The pulsating DC output at the secondary winding of T1 is trigger to the xenon tube. The xenon tube will flashing.

PCB assembly:

Shown in Figure 3 is the assembled PCB. Starting with the lowest height components first, taking care not to short any tracks or touch the edge connector with solder. Some tracks run under components, and care should be taken not to short out these tracks. All components with axial leads should be carefully bent to fit the position on the PCB and then soldered into place. Make sure that the electrolytic capacitors are inserted the correct way around. The LED has a flat spot on the body which lines up with the line on the

overlay. Now check that you really did mount them all the right way round!

Testing:

Adjust the VR1 at middle. Connect the AC line 220V into "220V" point. After the neon is light on. When is any sound, the xenon tube will flashing and the neon is light off. When the any sound stop, the circuit will not work and the neon is light on.

Application:

If you want increase to the light-flash. Can be adjusted by altering the value of capacitor C1 from 22µF/350V to 47µF/350V or 100µF/350V. If you used to capacitor 100µF/350V should to altering the value of 2KΩ 5W to 1KΩ 10W. For ST point is used to connect the switch. When you not to use the dynamic buzzer and adjusted to VR1 at "MIN" position.

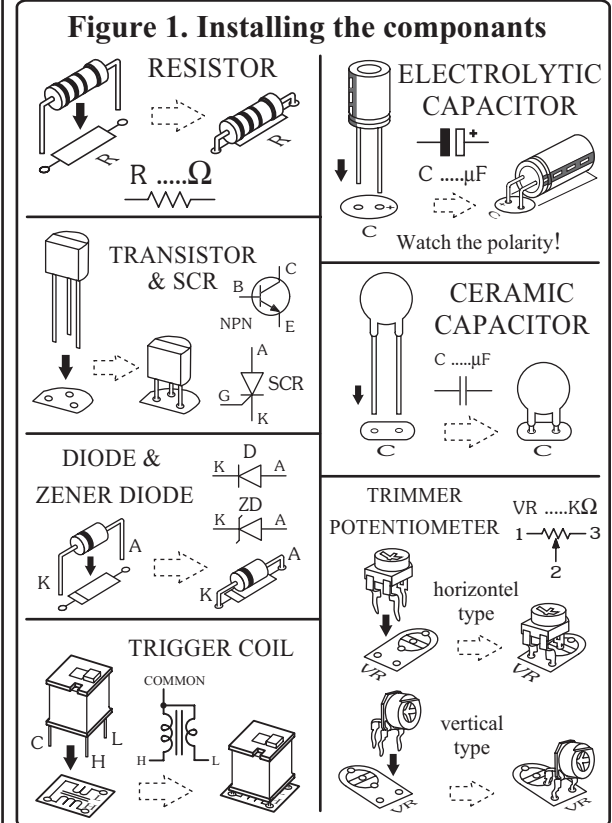

Troubleshooting:

The most problem like the fault soldering. Check all the soldering joint suspicious. If you discover the short track or the short soldering joint, re-solder at that point and check other the soldering joint. Check the position of all component on the PCB. See that there are no components missing or inserted in the wrong places. Make sure that all the polarised components have been soldered the right way round.

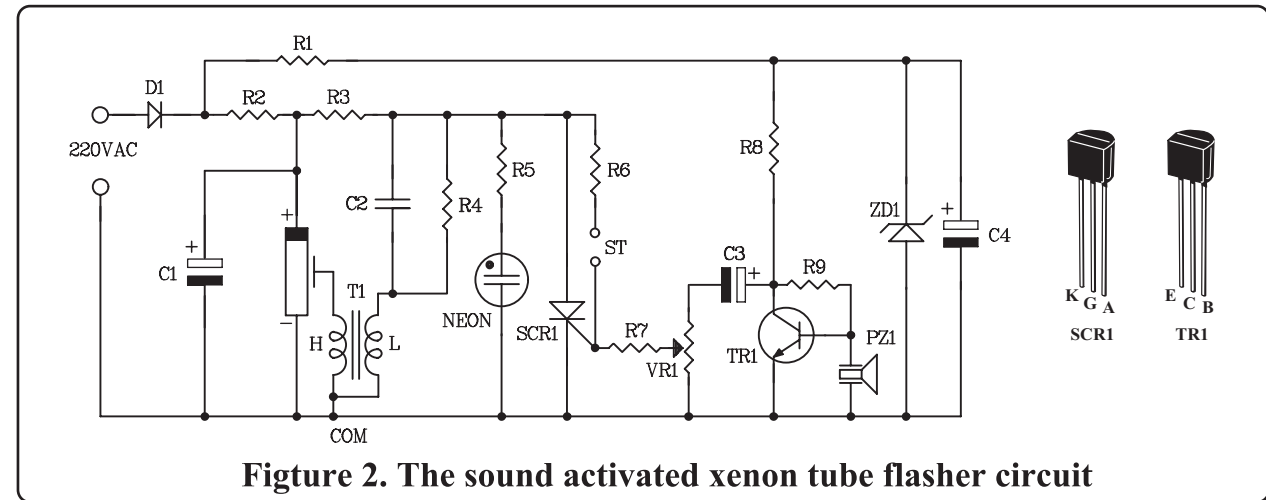

Figure 2. The sound activated xenon tube flasher circuit

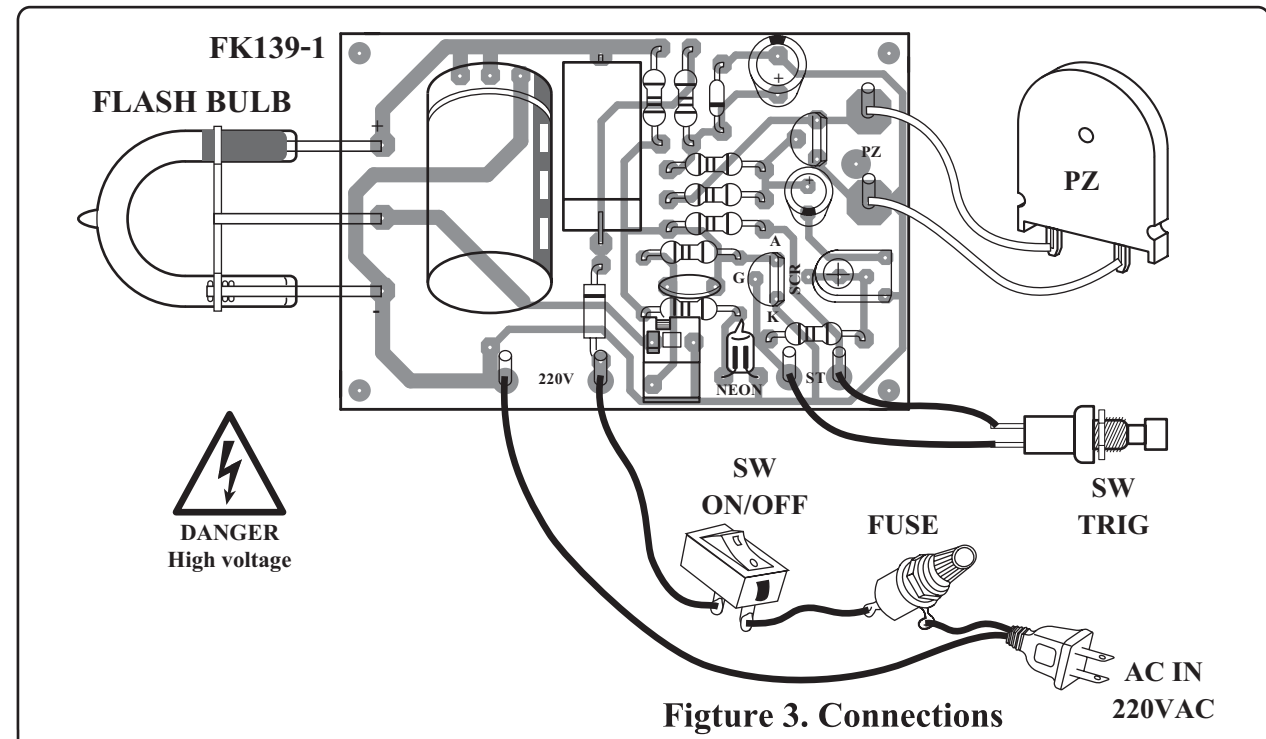
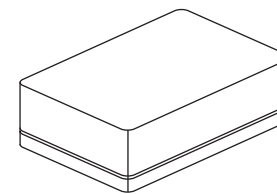

Figure 3. Connections



NOTE:

FUTURE BOX FB03 is suitable for this kit.

NEW KIT SET

| CODE FK | DESCRIPTION | POWER |
|---------|--|-------|
| 271 | LIGHT ACTIVATE ALARM (COCK VOICE) WITH SPEAKER | 3VDC |
| 272 | SPACE GUN 3 TONE WITH SPEAKER | 9VDC |