

# Kit 115 - Low Voltage Stereo Amplifier



This is a 1 watt stereo amplifier module Kit using two LM386N IC's from National Semiconductor. It is actually two of our Kit 17's on a single PC board. It will operate best from 6-12V DC and will work well from a battery since the quiescent current drain is only 10 mA, if the LED is not used. It requires no heat sink for normal use. The input and output are both ground referenced. Maximum output will be obtained with a 12V power supply and 8 ohm speaker, however it is particularly suitable for driving headphones from a supply as low as 4V.

## Specifications :

D.C. input : 4 – 12 V at 200 – 500 mA max.  
Idle current : ~ 10 mA w/o LED. (~20mA with LED)  
Power output : > 1 Watt max. @ 8 ohms, 12V DC  
~ 0.4 Watt RMS cont. per channel  
Freq. Resp. : ~ 40 Hz to 100 kHz, 8 ohm  
< 20 Hz - 200 kHz, 32 ohm, G=20  
THD : < 1 % @ 400 mW, 8Ω, 12V DC  
< 0.2 % @ 1Volt RMS, 8Ω, 12V  
Gain : x20 (26 dB) **OR** x200 (46dB)  
S/N ratio : > 80 dB, G = 20  
> 60 dB, G = 200  
Sensitivity : > 100 mV, G=20  
> 10 mV, G=200  
Input Z : ~ 10 k ohm

## Assembly Instructions :

Assembly is very straight forward, just follow the PC board overlay. Make sure you get the integrated circuit and the electrolytic capacitors the correct way around. The electrolytic capacitors are polarized, they have a + or - marked on them and they must be inserted correctly into the PCB. The IC and socket have a notch at one end, which is marked on the PC board overlay. Solder the sockets in place first, and then the 100 nF capacitors, making sure they are not above the IC sockets, before installing the IC's themselves. The LED cathode has a flat and is marked on the board. The anode is the longer lead. You can mount the LED on the box and use wire leads to the PC board. Leave the potentiometers until last.

The gain is adjustable from 20 to 200, i.e. 26 to 46 dB. Start with the jumpers J1 and J2 removed, this will give a gain of 20 which should be adequate for most applications. If you require more gain,

short circuit the pins with the jumpers provided. We have also provided input attenuation via the potentiometers. You should keep the IC gain as low as necessary to achieve full output, with the input potentiometer and your signal source at maximum. This will keep the signal to noise ratio as high as possible. All gain provided by the amplifier will reduce the S/N ratio by a similar amount, since the equivalent input noise figure is constant. The jumper may be replaced with a resistor if an intermediate gain level is required. See the National data sheet for more information.

If driving a pair of headphones, you may require a 100 ohm resistor in series with each output to reduce the output level, depending on headphone sensitivity. Make sure you start with the pots right down to check. A number of headphones may be driven from the one amplifier if you wish.

## Testing :

Check the voltage and polarity before connecting the battery or power supply. If it does not work, recheck all component positions and polarity. Check all solder joints, and all external wiring. **Don't forget the power switch.** The IC itself is quite robust, and there is very little else to go wrong. Remember when testing, it will not produce full output for more than a short duration because of limited heat dissipation. We found it easily exceeded the manufacturers specifications however.

## Circuit Description :

There are only a few external components, the IC contains most of the necessary circuitry. C1, C5 are the input coupling capacitors, which block any DC that might be present on the inputs. C2, C9 maintain DC bias levels in the gain adjustment (feed back) circuit. C4 provides power supply decoupling, and C6, C8 are the output coupling capacitors. C10, R2 and C11, R3 act as zobel networks providing a high frequency load to maintain stability where loud speaker inductive reactance may become excessive. The pots provide adjustable input level attenuation. The LED is a power on indicator, and may be omitted if not required.

The National data sheet contains further information about the LM386N. You may download it from the software download page on our website :

<http://www.kitsrus.com>

# Kit 115 - Low Voltage Stereo Amplifier

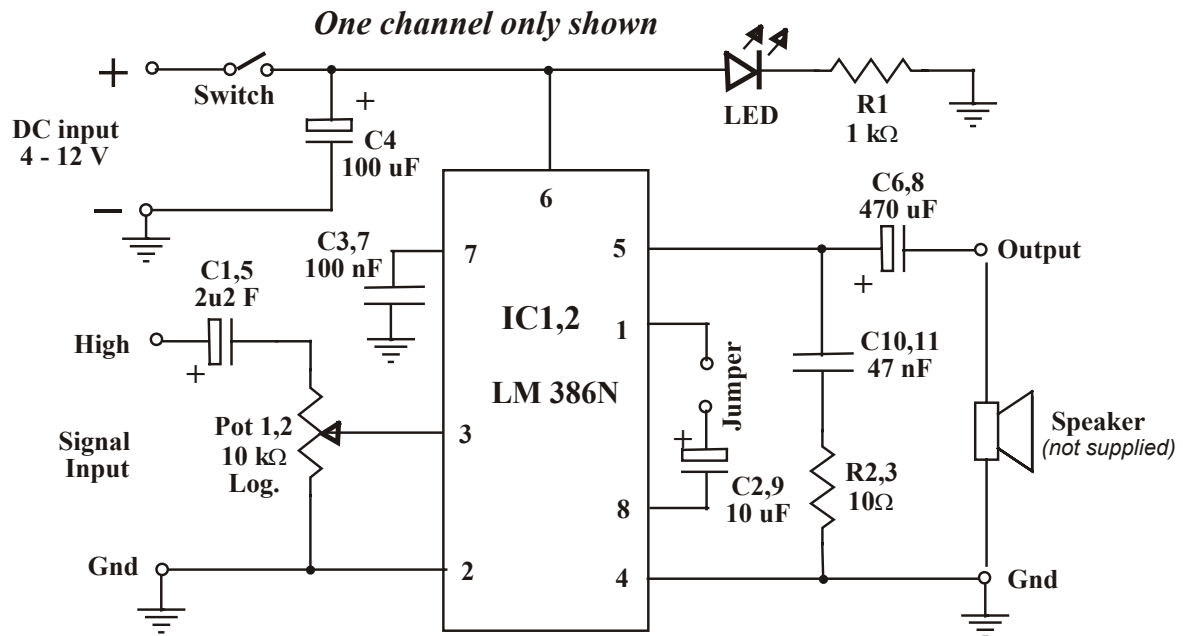

## Components :

C1, C5	2.2 uF / 16V ecap	2
C2, C9	10 uF / 25V ecap	2
C3, C7	100 nF mono (104)	2
C4	100 uF / 16V ecap	1
C6, C8	470 uF / 16V ecap	2
C10, C11	47 nF poly (473)	2
R1	1k ohm (brown, black, red)	1
R2, R3	10 ohm (brown, black, black)	2
Pot 1, 2	10k ohm log pot. (A)	2
IC 1, 2	LM386N Integrated Circuit	2
Kit 115 Printed Circuit Board		1
8 pin IC socket		2
3mm Red LED		1
2 pin header and jumper		2
PCB mount SPDT switch		1

# Kit 115 - Low Voltage Stereo Amplifier

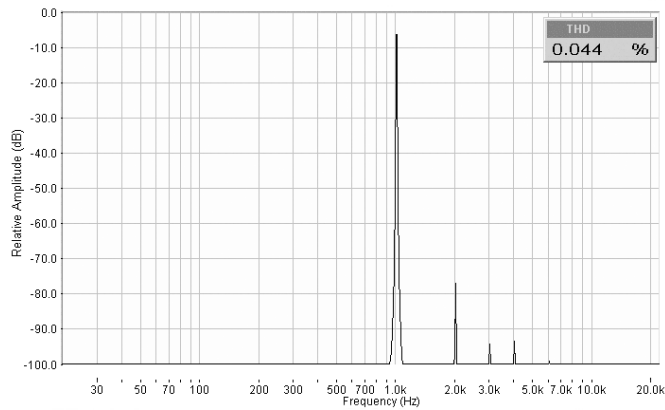
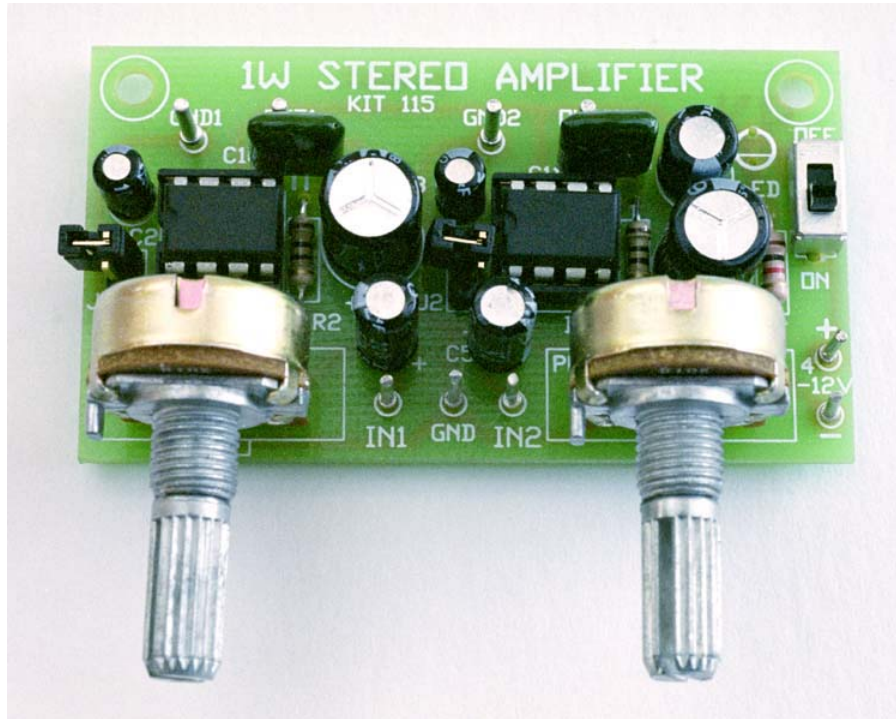

THD @ 1 Volt RMS  
32 Ohm Load

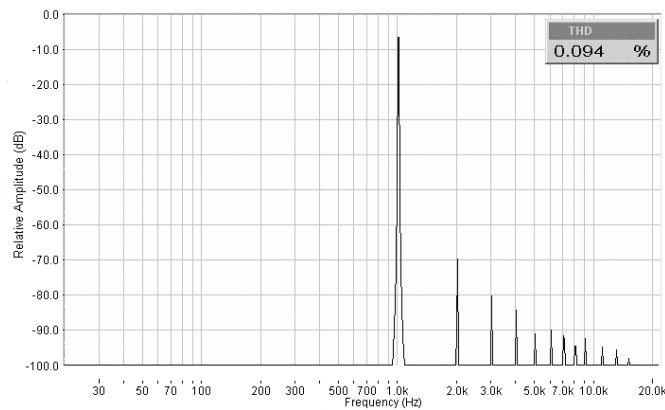

THD @ 1 Volt RMS  
8 Ohm Load