

Kit 67. DC SPEED CONTROLLER

There are three ways to vary the speed of DC motors:

- use a gear-box.
- use a series resistor. Measure the current drawn by the motor and then calculate the value of a series resistor needed to drop the voltage applied to the motor. Less voltage means the motor will slow down. The problem with this method is that the current drawn by the motor increases as the load on the motor increases. More current means a larger voltage drop across the series resistor and therefore less voltage to the motor. The motor now tries to draw even more current, resulting in the motor stalling.
- by applying the supply voltage to the motor for a variable amount of time. This is the method used in this kit. This is a revised circuit from earlier models.

How It Works

The circuit uses two timer/oscillators connected as a Pulse Width Modulator. The chip used is an nmos dual timer/oscillator, NE556. This IC has two 555 timers in one 14-pin IC package.

One 555 (IC1:B) is configured as an astable oscillator. The output frequency of the trigger pulses is given by:

$$f = 1.44 / ((R_3 + 2R_4)C_2), \text{ or about } 410\text{Hz.}$$

The time period for the high output is given by

$$T_{\text{HIGH}} = 0.69(R_3 + R_4)C_2 \text{ seconds.}$$

And, the low output by $T_{\text{LOW}} = 0.69R_4C_2$ seconds.

The second 555 (IC1:A) is configured for Pulse Width Modulation. It is set up in monostable mode. It is triggered with the continuous pulse train from the first 555. However, by also applying a DC voltage to pin 3 the comparator reference levels will be changed from their nominal levels of one-third & two-thirds of the supply voltage. This has the effect of modulating the pulse width as the control voltage varies.

The control voltage is supplied via transistor Q1, which is configured as an emitter-follower. This means that the emitter output voltage follows the base input voltage (less 0.6 volt base-emitter drop). This configuration gives us a low output impedance voltage source with which to drive the control input of the timer. This makes the control voltage less susceptible to the loading effect of the timer control input.

The output from the timer is a continuous stream of pulses whose width is controlled by the voltage level applied to the control voltage input. This modulated output drives a MOSFET, Q2, which is used to switch the voltage to the DC motor. Download the data sheet

<http://www.kitsrus.com/pdf/irf530.pdf>

The maximum ON time of the output pulse, and therefore maximum motor speed, can be set by adjusting the trimpot P1 (and maybe resistor R1 as well).

The motor is always connected to the terminal block, pins **M+** and **M-**. If the motor is driven with the **same** power supply as the controller then insert link LK1. If **separate** power supplies are used to drive the controller and the motor, then remove link LK1 and connect the positive & negative motor power supply lead to the pins marked **E+** and **E-**. This ties together the ground lines from each supply by a connection on the PCB.

Construction

Check each component against the Listing given on the next page. Make sure to get the orientation of the diode and electrolytic capacitor correct. The bar on the diode is the cathode and corresponds with the bar on the overlay printed on the circuit board. Slide the terminal blocks together to make the 6 pin block.

It is generally easiest to add and solder the lowest height components first to the PCB. Then add the taller components. Note there is one link to add to the board. Leave the second link LK1 until after you read the section below.

10K potentiometer. This is mounted from the back through the hole on the right of the board. Screw it down with the nut. Use some of the wires from the resistors to attach the three pins from the pot to the 3 pads marked with the circles on the overlay. We have not included a knob with the kit so that you can attach the one you like best, or use a spare one if you have it.

Operating Specifications

Kit supply, Vcc: 5V - 16V which is the operating range of the 556 IC.

DC motor: The IRF530 MOSFET is rated at 100V so this is the maximum voltage that you can run the motor at. The maximum current the MOSFET can handle is 16A. However the PCB tracks can only handle up to 7.5A at 30° C. You can always thicken up the tracks with wire links to increase the current handling capacity. Even so the maximum motor current will depend on just how hot the MOSFET gets when running. While 16A is the absolute maximum in reality it will be something less than this.

How to Connect. 1. Always connect the two motor wires to **M+** and **M-** on the terminal block.

2. Always connect the power supply to the kit (5V-16V DC) to the terminal block **V+** and **V-**

3. You have a **choice** whether to use the same DC voltage to both the motor and the kit, or to use a different voltage for the motor (eg, it might be a 24V motor) from the 5-16V for the kit. If you use the **same**

Kit 67. DC SPEED CONTROLLER

voltage (5V – 16V) for **both** the kit and the motor then just add the link LK1 as marked on the PCB. Nothing goes into the **E+** and **E-** positions on the terminal block.

If running the motor from its own supply then do **not** insert the link LK1. Connect the motor external positive and negative supply to the terminal block **E+** and **E-**.

Note: We have found that a drop in the kit's supply voltage causes the motor speed to drop. This normally happens when running the kit and motor from the same supply. In this case adjust trimpot P1 to get maximum speed. You may also need to vary resistor R1 as well.

See the next page for how to adjust the trimpot for maximum speed.

What To Do If It Does Not Work

Check the orientation of the diode, the IC and the electrolytic capacitor. Did you make the 3 connections from the potentiometer pins to the pads? Did you add the links as required, depending on whether or not you used the same power source for the motor as the controller? Check that all the resistors are in their correct positions. If you have a CRO or frequency meter check the output on pin 5 of the 556. Photos of this are on the next page

COMPONENTS			
Resistors 5% 1/4W:			
10R brown black black	R6		1
470R yellow violet brown	R2		1
560R green blue brown	R1		1
10K brown black orange	R5		1
33K orange orange orange	R3		1
2K2 red red red	R4 R7		2
500R (501) Koa trimpot	P1		1
10K potentiometer, washer & nut			1
1N4004	D1		2
10uF/50V ecap	C1		1
100nF 104 monicap	C2 to C7		6
100uF/25V electrolytic	C8		1
Heatsink (HS110, HS313)			1
Nmos LM/NE556	IC1		1
IRF530 mosfet	Q2		1
BC547 Transistor	Q1		1
14 pin IC socket			1
Nut & screw for heatsink			1 set
Two pole terminal block			3
Kit 67V31 PCB			1
Large Box P4210 & 4 screws			1

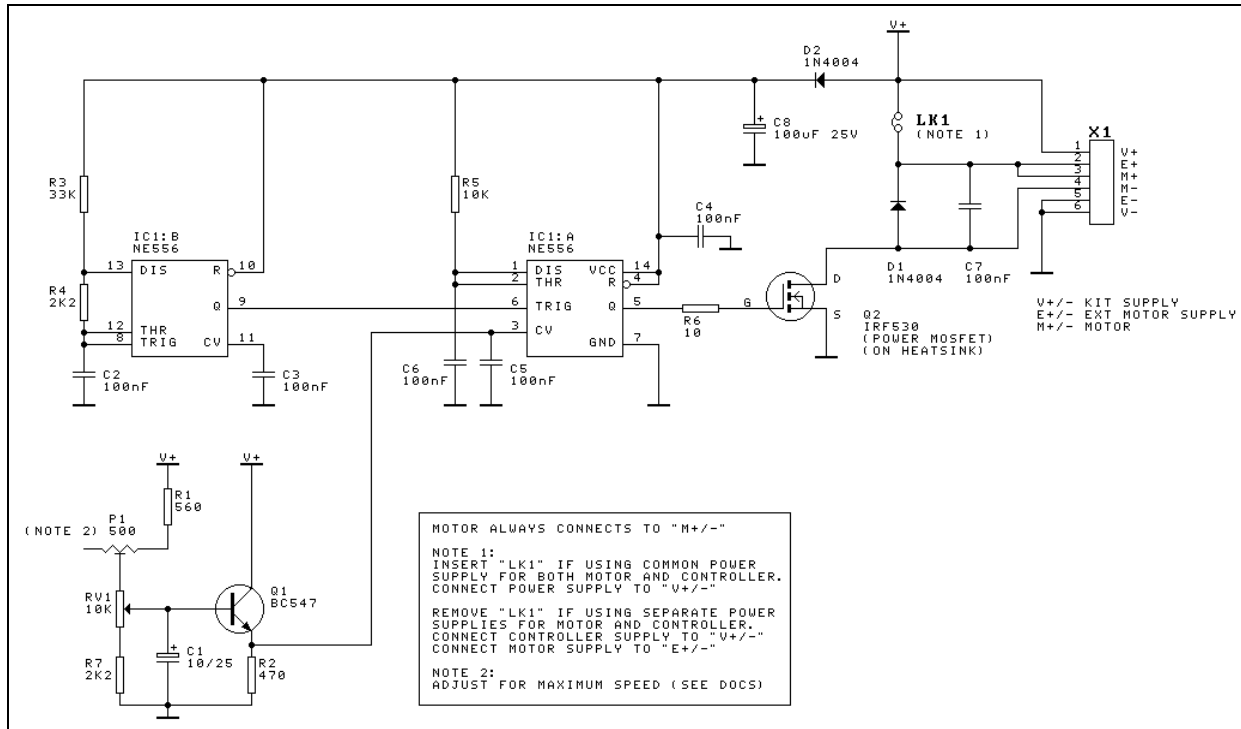

Kit 67. DC SPEED CONTROLLER

Adjusting for Maximum Speed

You do not need a CRO to adjust the trimpot for maximum speed but it helps if you can also see what is happening. Take the input from pin 5 of the LM/NE556. At the Slowest setting of the potentiometer this is what you should see.

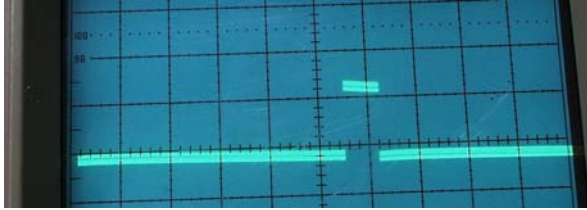

(Sorry about the ripple!)

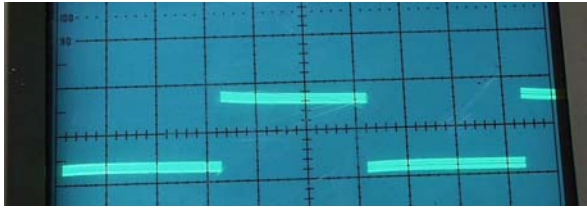

This is at about the mid-point of the Potentiometer as the pulse width and thus the motor speed is increased.

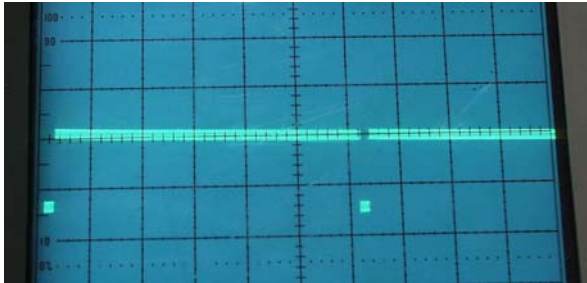

At the Fastest position and using the trimpot P1 to trim for about 99% pulse width. If you over trim then the 556 will 'trip-over' itself and the motor speed will drop. Here is what you see when you just over trim the trimpot from the above photo.

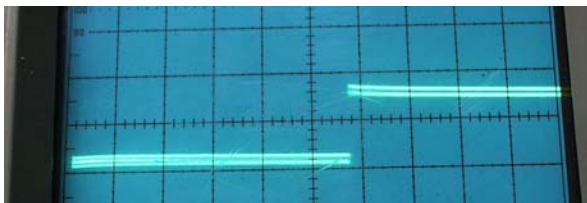

If you have the motor attached then you will hear it drop in speed by about 10% - 20% when the 556 passes through this transition point.

Note that you will have to retrim if the supply voltage changes. Note also that the 556 will heatup a little after it

is turned on and this heating will also affect the trim position. The warming may be reduced by increasing R6 to 100R but we have not experimented with this. So leave the kit turned on for a few minutes before trimming if you want to get the maximum trim position possible.

If you turn the trimpot but get nowhere near the 99% pulse width position then short circuit R1 underneath the PCB and try again with the trimpot alone. There are variations between different brands of 556 and we have found some which required 650R – 800R but others which only needed 400R to trim to maximum. Again we did not investigate this.

See us at <http://www.kitsrus.com>

(Documentation October 19, 2003. Changed from IRFZ44N to IRF530 MOSFET.)

