

C039 DTMF DEVELOPMENT BOARD

DTMF Development Board offers a very convenient way to generate DTMF tones and demodulate it. It uses the famous MT8880/MT8888 DTMF transceiver IC from Mitel.

- Easy 10 pin Box Header connector for interfacing data/control pins
- Crystal derived frequency source for accurate generation and demodulation of DTMF tones for your project
- Onboard upto 350 mW audio amplifier block for DTMF tones with Volume Adjust Preset
- 5V Supply sourced via interfacing Box Header
- Relimate/Berg type analog connection
- Four mounting holes 3.2 mm each
- PCB dimensions 56 mm x 49 mm

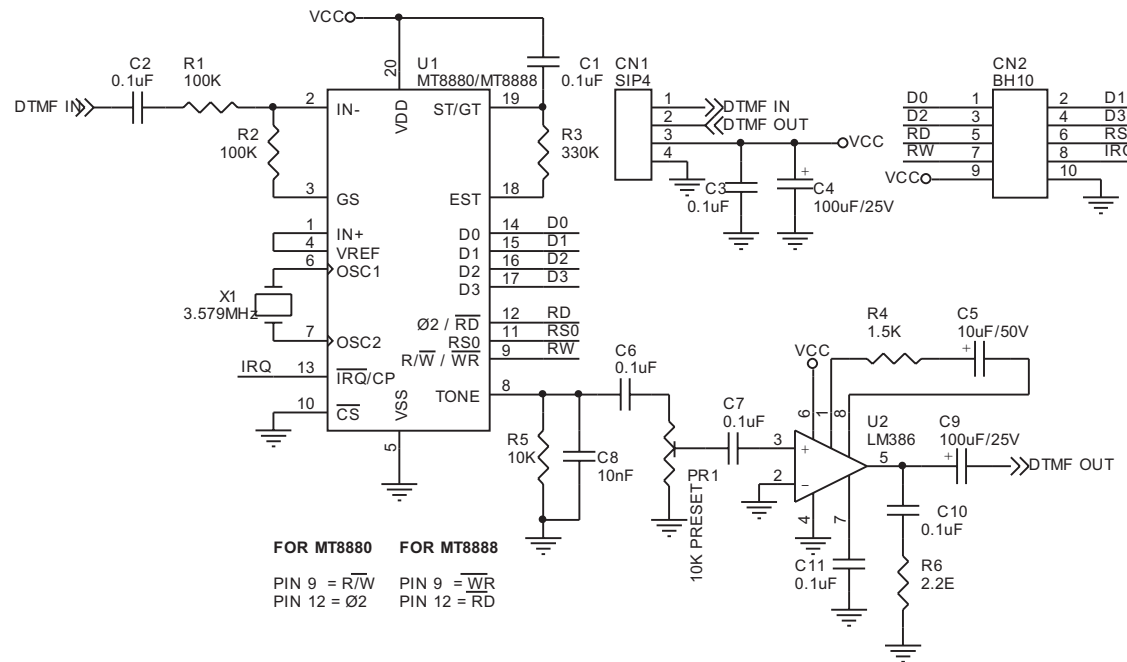
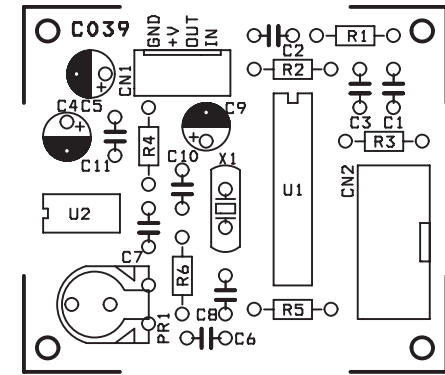

SR.	QTY.	REF.	DESCRIPTION
1	1	CN1	4 PIN BERG CONNECTOR
2	1	CN2	10 PIN BOX HEADER
3	7	C1,C2,C3,C6,C7,C10,C11	0.1uF
4	2	C4,C9	100uF/25V
5	1	C5	10uF/50V OR 63V
6	1	C8	10nF
7	1	PR1	10K PRESET
8	2	R1,R2	100K
9	1	R3	330K
10	1	R4	1.5K
11	1	R5	10K
12	1	R6	2.2E
13	1	U1	MT8880/MT8888
14	1	U2	LM386
15	1	X1	3.579 MHz CRYSTAL
16	1	SOCKET	20 PIN DIP IC SOCKET
17	1	SOCKET	8 PIN DIP IC SOCKET

