

# K138. TWO LED FLASHER

This kit wires the popular 555 IC as an astable, free-running multivibrator. In other words it is wired as a square wave oscillator. It has a double ended output connection in which one LED is OFF when the other is ON, and vice versa.

For an animation of what happens in this kit go to

[http://www.williamson-labs.com/480\\_555.htm](http://www.williamson-labs.com/480_555.htm)

Note the animated charging and discharging of the capacitor. Note which resistors are involved with the charging and with the discharging. Watch which LED's are on in what part of the cycle. A few minutes watching this animation and making it go faster will give an excellent understanding of how this circuit works.

The capacitor C2 charges exponentially through resistors R1, R2 and the resistance of the trimpot. When C2 has charged to about  $\frac{2}{3} V_{CC}$  it stops charging and it discharges to about  $\frac{1}{3} V_{CC}$  through R2 and the trimpot resistance via pin 7.

There are links on this site to download the 555 Data Sheet and a lot of other relevant information.

For another excellent website devoted to the 555 see

<http://www.uoguelph.ca/~antoon/gadgets/555/555.html>

In the following website

[http://ourworld.compuserve.com/homepages/Bill\\_Bowden/555.htm](http://ourworld.compuserve.com/homepages/Bill_Bowden/555.htm)

you can enter values for R1, R2 and C and see what flash rates they would give.

**Assembly.** It is best to add the lowest height components – the resistors – first. Read the color code to make sure they are the right ones in the right places. The ecap and the LEDs must be put in the right way around. The two pins make it easy to attach alligator clips to the board. You do not have to use them if you do not want to.

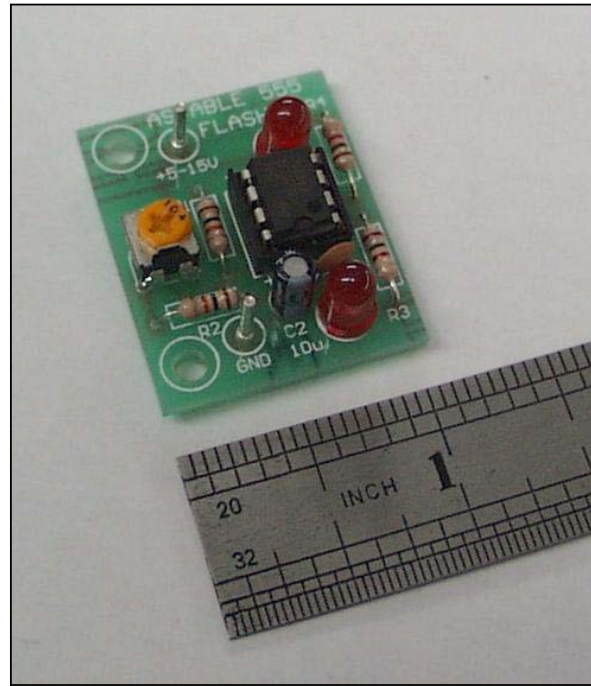

Finally, connect a battery or power supply between 5V and 15V DC to the pins. The LEDs should start to flash off and on.

## COMPONENTS

Resistors 5%, carbon film, 1/4W:

820R grey red brown	R3 R4	2
1K brown black red	R1 R2	2

Koa trimpot 100K 104	Trimpot	1
ceramic capacitor 10n 103	C1	1
electrolytic capacitor 10uF	C2	1
5mm red LED	L1 L2	2
LM/NE555	IC1	1
8 pin IC socket		1
Terminal pins		2
K138 PCB		1

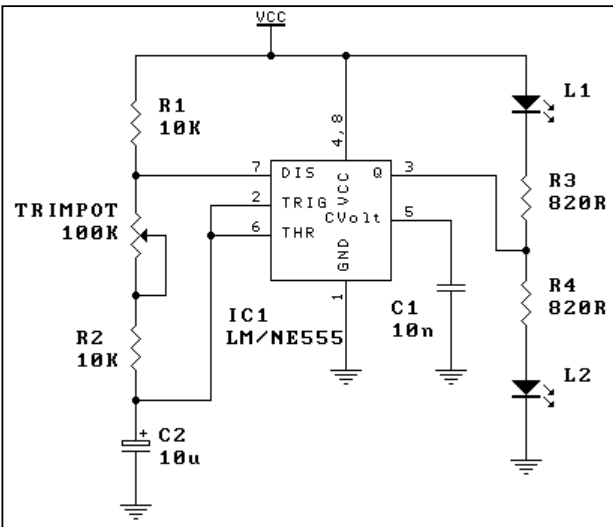

For more of our kits go to

<http://www.kitsrus.com>

If you have any questions email me at

[peterhk@kitsrus.com](mailto:peterhk@kitsrus.com)

(Documentation: September 2, 2002.)